



विज्ञान एवं प्रौद्योगिकी विभाग  
DEPARTMENT OF  
SCIENCE & TECHNOLOGY



## U.S. INDIA COLLABORATIVE FOR SMART DISTRIBUTION SYSTEM WITH STORAGE

Supported under

**INDO-U.S. JOINT CLEAN ENERGY  
RESEARCH & DEVELOPMENT CENTRE**

**COMPENDIUM**

**2017-2023**

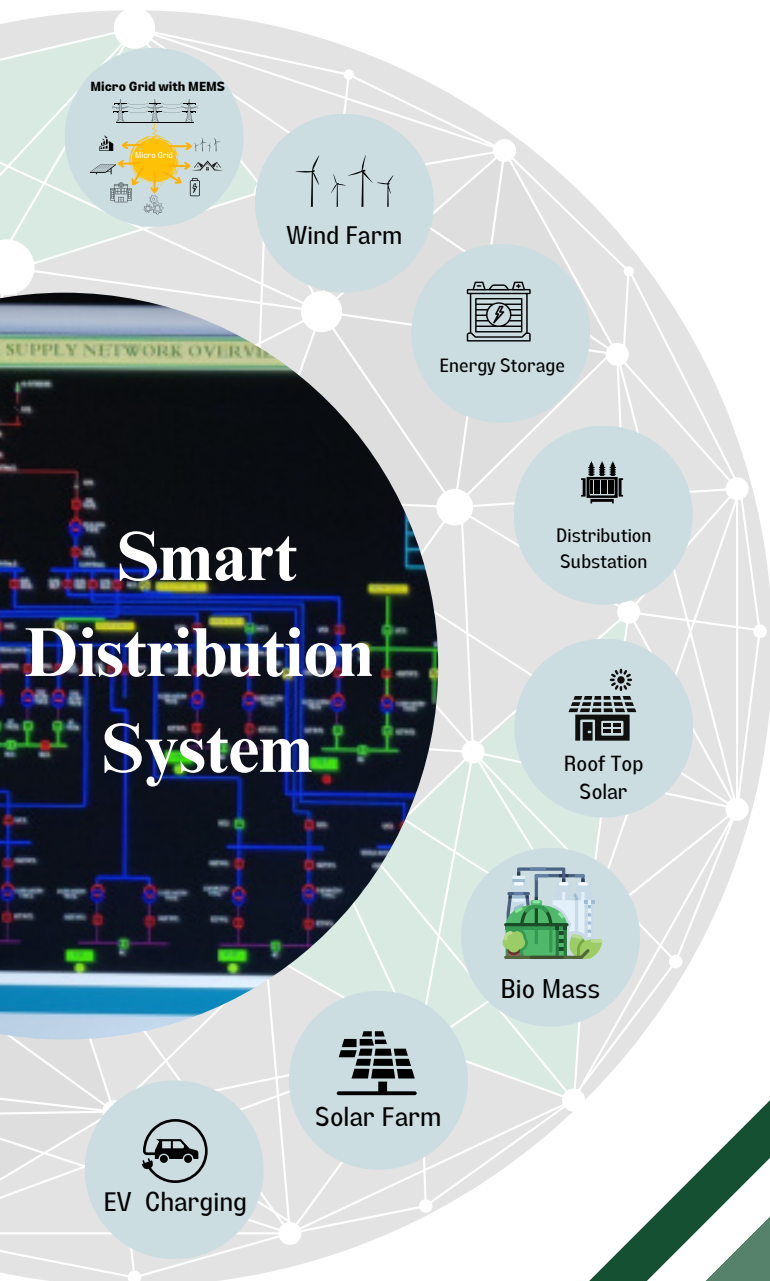



# U.S. INDIA COLLABORATIVE FOR SMART DISTRIBUTION SYSTEM WITH STORAGE

funded under

## Indo-U.S. Joint Clean Energy Research & Development Centre

### Compendium 2017-2023

### Funded By



विज्ञान एवं प्रौद्योगिकी विभाग  
DEPARTMENT OF  
SCIENCE & TECHNOLOGY

सत्यमेव जयते



IUSSTF  
Indo-US Science and Technology Forum



#### Copyright Information

This report has been prepared by UI-ASSIST Consortium Partners. Information in this report can be used without obtaining the permission of authors; however, the material used from this report should be duly acknowledged by way of citing the name of the authors, report, and publishing year.



# UI-ASSIST Consortium Partners

## INDIA Partners



Shramik Bharti Foundation  
श्रमिक भारती फाउन्डेशन



Customized Energy Solutions

Panasonic

## US Partners



UI-ASSIST COMPENDIUM

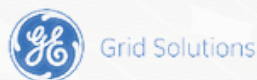





# Message from DST



सत्यमेव जयते

डा. अनिता गुप्ता  
Dr. Anita Gupta



सलाहकार एवं प्रमुख वैज्ञानिक 'जी'  
जलवायु परिवर्तन एवं स्वच्छ ऊर्जा  
विज्ञान और प्रौद्योगिकी विभाग  
भारत सरकार

SCIENTIST 'G' ADVISOR & HEAD,  
Climate Change & Clean Energy (C&E)  
Department of Science & Technology  
Government of India

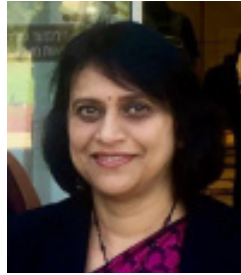

## MESSAGE

U.S.-India bilateral clean energy engagements and the achievements of the U.S.-India Strategic Clean Energy Partnership (SCEP) have played a critical role in strengthening energy security, creating opportunities for clean energy innovation, addressing climate change, and creating employment generation opportunities.

The **Indo U.S. Joint Clean Energy Research and Development Centre (JCERDC)** was established in 2010 by the Ministry of Science and Technology, Govt. of India and the U.S. Department of Energy. It was a first-of-its-kind initiative which has been successful, not only in terms of the technical and research objectives, but also as a model for large bilateral public-private partnerships.

The **US-India collAborative for smart diStribution System wIth STorage (UI-ASSIST)** project awarded under the JCERDC program in 2017 is one of the largest initiatives under the Smart Grid and Energy Storage area supported by the Department of Science and Technology which addressed critical issues related to the adoption and deployment of smart grid concepts along with Distributed Energy Resources (DERs) including storage in the distribution network for its efficient and reliable operation.

The project outcomes will pave a path for societal acceptance, ensure maximum impact and value of the integrative active distribution system employing renewable sources, storage and microgrid solutions and will have implications on policies in the area. The compendium presents the Journey and highlights the key outcomes of the consortium from 2017-2023.

I would like to congratulate the UIASSIST consortium for its achievements and wish them the best for future.



(Dr. Anita Gupta)





# Message from DOE



## Department of Energy

Washington, DC 20585 Merrill Smith, Senior Advisor  
Grid Systems and Components  
Office of Electricity  
Department of Energy



Message

The mission of the Energy Department (DOE) is to ensure America's security and prosperity by addressing its energy, environmental and nuclear challenges through transformative science and technology solutions. Keeping the power flowing to American homes and businesses is a critical necessity for everyday life and economic vitality. DOE works to keep the grid secure from cyber and physical attacks; partners with states and other stakeholders to plan more resilient infrastructure that can better withstand extreme weather events; and supports efforts to increase grid efficiency and energy storage as more renewable energy sources come online.

The DOE's Office of Electricity (OE) is focusing R&D efforts to support an electric grid that is reliable, resilient, secure, and affordable. OE is supporting these tenants while also working to address grid decarbonization, energy justice (efforts to reduce social inequalities), workforce development, growing physical and cyber threats, and supply chain globalization.

The US has recognized that energy and climate challenges are a global issue and must be addressed through partnerships with other countries around the world. In 2009, the governments of India and the United States formalized our partnership for advancing clean energy research, development, and workforce with the U.S.-India Partnership to Advance Clean Energy (PACE) agreement. One component of the PACE initiative was research (PACE-R) and in 2010 the U.S. Department of Energy and Government of India established the U.S.-India Joint Clean Energy Research and Development Center (JCERDC). Over the last 14 years, the goals of PACE and JCERDC have been reaffirmed by the Indian and US governments, including a joint statement from June 2023 around the meeting of President Joseph R. Biden, Jr., and Prime Minister Narendra Modi.

After funding three collaborative efforts in the first phase of JCERDC, the next phase of collaborative funding targeted the areas of smart grids and storage with goals to have a comprehensive effort that translated research and development results into laboratory scale test beds and then field demonstrations. Additionally, collaborative funding would consider the social impact, policy implications and workforce needs related to advances in clean energy technology solutions.

The US Department of Energy acknowledges the Government of India's Department of Science and Technology and Indo-U.S. Science and Technology Forum for their partnership from the development of this JCERDC initiative and request for proposals in 2016 to the completion of the UI-ASSIST project this year. The coordination across two countries and 31 research partners created unique opportunities and challenges and we were able to work together towards goals set with PACE and JCERDC initiatives.

This compendium provides a summary of the key activities, accomplishments, and collaborations from the UI-ASSIST project. Readers will find work for smart grid systems including models of advanced distribution systems, microgrids, storage and renewable energy resources, simulations that integrate controls, communications and cybersecurity aspects of the electric power grid, tools that provide planning and operational support for forecasting, reliability and resiliency; experiments for real-time evaluation in laboratory test beds; implementations in field demonstrations and much more. Additionally, the compendium provides insights into how these technological advances relate to existing policies and their impact on society. Also outlined are key accomplishments in the areas of developing India-US collaborative research teams and advancing workforce for these new technologies.

I would like to thank the UI-ASSIST US leaders, Dr. Noel Schulz and Dr. Sanjeev Pannala, Washington State University and Dr. Anurag Srivastava, West Virginia University for all their efforts in making the UI-ASSIST project successful. These efforts included the creation of the US team with a diverse team across the electric grid ecosystem including utilities, universities, national laboratories, consultants, and others; the extensive coordination with the UI-ASSIST India leadership and partners; the management of logistics and collaborations across sixteen US partners; and the vision and work to translate the objectives and goals of the proposal into numerous India-US collaborative accomplishments.

(Merrill Smith)







# Message from IUSSTF



Indo-US Science and Technology Forum

**Dr. Chaitali Bhattacharya**  
Interim Executive Director (Principal  
Science Officer)



Message

The United States and India have a long history of scientific and technical collaborations, which has resulted in numerous inventive solutions to global challenges. As climate and clean energy leaders, both countries have repeatedly reaffirmed their commitment to addressing the growing challenge of climate change by working together towards shared goals of lowering emissions and implementing sustainable energy solutions.

The Indo-U.S. Joint Clean Energy Research and Development Centre (JCERDC) was established in 2010 by the Ministry of Science and Technology, Government of India, and the United States Department of Energy with the essence of bringing together the best and brightest researchers of both the countries for conducting cutting-edge research and developing innovative, and rapidly deployable energy solutions to meet the pressing need.

The Indo-U.S. Science and Technology Forum (IUSSTF) serves as the Secretariat for the JCERDC. Having had the privilege to implement three successful projects encompassing priority areas of Solar Energy, Second-Generation Biofuels, and Building Energy Efficiency under the JCERDC phase I, we are delighted to present in this compendium, the accomplishments of the fourth project - Smart Grids and Energy Storage, supported under the JCERDC phase II. The U.S.-India collaborative for smart diStribution System wIth StORage (UIASSIST) was supported with the aim of bridging the gap between smart grid, storage, and renewable energy research and facilitating its future implementation by utilities around the world in distribution system operation and planning.

The strength of the UIASSIST project lied in bringing together the Indo-U.S. research community to execute complementary research studies, thereby encompassing wider research themes in the field of smart grid and generating faster and more robust results. Different paradigms available in Indian and U.S. settings as well as exposure to new systems enabled cross-learning and outside-the-box thinking among the researchers for finding collaborative solutions to common challenges. The project provided a platform for training the next-generation workforce and sharing of best practices by the industry. All this led to building the smart grid community and expanding its footprint.

The landmark achievements of the unique consortia during its six-year journey to evolve the future distribution grid that will allow increasing penetration of Distributed Energy Resources (DER) towards a carbon-free electricity system are highlighted in this compendium.

(Chaitali Bhattacharya)





विज्ञान एवं प्रौद्योगिकी विभाग  
DEPARTMENT OF  
SCIENCE & TECHNOLOGY

**Dr. J.B.V. Reddy Scientist 'F',**  
Climate Change and Clean energy  
Department of Science and technology (DST)  
Ministry of Science and Technology  
Government of India



Foreword

India has set ambitious clean energy targets that include 500 GW non-fossil energy capacity, 50% renewable energy, and net zero emissions by 2030 and 2070, respectively. These targets will help India meet its growing energy needs while reducing reliance on fossil fuels and mitigating climate change. Achieving India's clean energy targets will require significant investment and effort. However, the benefits of a clean energy transition are clear. A clean energy future will create jobs, reduce pollution, and help India achieve its climate goals. India is already making significant progress on its clean energy transition.

The Department of Science and Technology (DST) which plays a pivotal role in the promotion of Science & Technology in the country is working towards India's clean energy targets, through various initiatives by harnessing state-of-art research led innovative and cost-effective materials, technologies, and processes for clean energy advancement in the country. The Indo-U.S. joint clean Energy R&D centre (JCERDC) is one such joint initiative of the Ministry of Science and Technology, Govt. of India and the U.S. Department of Energy. The program began in the year 2012 with IUSSTF as the implementing agency. In 2015, the program was extended to support the areas of Smart Energy Grids and Energy Storage.

The "US-India collABorative for smart diStribution System wLth STorage (UI-ASSIST)" project was awarded for funding by DST and DOE in 2017 under Phase II of the JCERDC Program.

The smart grid research component allowed both India and the United States to explore and analyse the concept of microgrids to enable optimal integration and utilization of Distributed Energy Resources (DERs) while the grid storage research component explored the contributions of storage to enhanced grid resilience, reliability, efficiency, and performance. The project also brought to the forefront the importance of a regulatory framework in the Indian Power Sector that includes the concept of the Distribution System Operator (DSO), opening possibilities to perform a wider array of functions and ensure more optimal utilization of distributed energy resources.

The main aim of the Indo-US joint project 'UI-ASSIST', involving 31 consortia partners from US and India, was to work on a broad spectrum of required components and sub-systems for the development of smart distribution systems relevant to both countries. This compendium summarizes the key outcomes and deliverables of the UI-ASSIST project resulting from six years of efforts of the Indo-US Consortium.

(Dr. J.B.V. Reddy)





# Acknowledgement

With the growth of smart equipment integrated with latest Information and Communication Technology (ICT), Renewable Energy Resources (RES), and Energy Storage Systems (ESS), there was a need to advance research, development, and field implementation knowledge for smart Electrical Power Distribution Systems (EPDS) across the globe. Based on the need for such modernization of the distribution systems, the UI-ASSIST project was conceptualized. In the project, sixteen consortia members from US and fifteen consortia members from India worked together to develop the next generation of smart distribution system, integrated with renewable energy and storage. The project was funded by Indo-US Science and Technology Forum (IUSSTF) through Department of Science and Technology (DST) from India and Department of Energy (DoE) from USA.

First, we would like to extend our sincere and heartfelt thanks to IUSSTF, DST, Government of India, and U.S. DoE, for providing the necessary funding support and giving our team the opportunity to collaborate and advance the key objectives of the UI-ASSIST project. We would also like to thank the Indian Project Monitoring Committee (PMC) members and U.S. Advisory Board Members for providing their guidance and inputs from time to time to steer the project in the right direction.

We thank all the consortia members from India and US sides for their key contributions in the project in their work accomplishments and cost-share contributions. Without their collaboration and work, we would not have been able to execute the project successfully. Finally, special thanks to all the students, project staff, and other key stakeholders, who worked in the project relentlessly to make it successful.



---

**Ankush Sharma, Indian Institute of Technology Kanpur, India Lead**  
**Noel Schulz, Washington State University, US Lead**





# Contents

1.	<b>Executive Summary</b>	01
2.	<b>Program Background - About JCERDC</b>	04
2.1	<b>Overview</b>	05
2.2	<b>Background</b>	05
3.	<b>Project Background/About UI-ASSIST project</b>	07
4.	<b>Purpose, Activities, Deployments and Accomplishments under the Project</b>	10
4.1	<b>Purpose</b>	10
4.2	<b>Activities</b>	10
4.3	<b>Technical Accomplishments</b>	10
4.3.1	<b>Energy Storage</b>	11
4.3.2	<b>Microgrid and Active Distribution System</b>	14
4.3.3	<b>Cyber Infrastructure and Security</b>	20
4.3.4	<b>Advanced Distribution Management System (ADMS)</b>	24
4.3.5	<b>DSO - Market and Regulatory Issues</b>	28
4.3.6	<b>Social Impact Analysis and Policy Recommendation</b>	32
4.4	<b>Deployments: Field and Lab Pilots</b>	41
4.4.1	<b>Field Pilots</b>	41
4.4.2	<b>Lab Test Beds</b>	53
4.5	<b>Other significant outcomes</b>	63
4.5.1	<b>Benchmark Systems</b>	63
4.5.2	<b>Micro Phasor measurement unit (<math>\mu</math>-PMU)</b>	64
4.5.3	<b>DSO White Paper</b>	66
4.5.4	<b>Resiliency Assessment Tool for Active Distribution Network</b>	68
4.6	<b>Highlights of US-India Collaborative Activities</b>	69
4.7	<b>Capacity Building</b>	71
5	<b>Conclusions</b>	75
5.	<b>Annexures-A: Research Publications from the project</b>	79
6.	<b>Annexure-B: General References</b>	107
7.	<b>Annexure-C: List of the Project Team Members</b>	115







# List of Figures

Figure 1:	Conventional Electric Grid (Source: Internet)	07
Figure 2:	Typical Smart Electric Grid	07
Figure 3:	UI-ASSIST Thematic Areas and Activities	10
Figure 4:	Battery sizing methodology for DT peak shaving application (Cat A-TERI & BRPL pilot)	11
Figure 5:	Semi-urban AC microgrid distribution system at IIT Kanpur campus	12
Figure 6:	System level modelling of BESS for WSU Urban distribution system	13
Figure 7:	Storage Modeling Philosophy	13
Figure 8:	Value Stream Analysis of Storage systems	13
Figure 9:	Thermal Energy Storage System Horizontal Outside Tank	14
Figure 10:	Activities of Energy Storage Systems under UI-ASSIST	14
Figure 11:	A general structure of a microgrid system	15
Figure 12:	Focus of key R&D activities in microgrids and active EDNs	15
Figure 13:	Block diagram of the SMC control scheme as primary controller	16
Figure 14:	Proposed hybrid microgrid structure	17
Figure 15:	Complete control architecture of a solar PV based DER connected to the main AC grid.	17
Figure 16:	Development of secondary controllers with (a) full communication, and (b) reduced communication.	17
Figure 17:	Field test environment for LV DC distribution implementation	17
Figure 18:	Two different architectures of rural DC grids: 1) Centralized generation centralized storage (Left side), 4) Distributed generation distributed storage (Right side).	17
Figure 19:	DC microgrid architecture with control mechanism under islanded mode.	18
Figure 20:	Overview of collaboration outcome on modern grid protection	18
Figure 21:	Example case study of protection schemes on DER connected distribution system	19
Figure 22:	(a) Magnitude phase plane of ID, (b) Flowchart of proposed ID-based protection and fault detection scheme	19
Figure 23:	Scheme of proposed $\Delta V - \Delta I$ plane-based fault detection & classification in LV DC microgrids	19
Figure 24:	Role-based access control for the critical information infrastructure	21
Figure 25:	Nanogrid based aggregator framework	23
Figure 26:	Key functions and features of the developed ADMS platform	24
Figure 27:	Measurement based (a) traditional, (b) proposed approaches for load modelling	25
Figure 28:	(a) Conventional Wavelet transform, (b) Proposed additional breakup of coefficients in repeated Wavelet transform (a and d coefficients refer to approximation and detailed coefficients)	25
Figure 29:	Stage-wise approach for integrated VVO, NR, and DR in active unbalanced EDNs	26
Figure 30:	Expected benefits of DR	26
Figure 31:	Proposed (a) centralized, and (b) decentralized EV pricing strategies	26
Figure 32:	Schematic of existing SCADA and Newly Developed ADMS at IIT Kanpur	27
Figure 33:	Developed ADMS architecture	27
Figure 34:	MDM – WSO2 ESB – ADMS in Kanpur field pilots	27
Figure 35:	GIS mapping of IIT Kanpur distribution network in the developed ADMS HMI	27
Figure 36:	CIM based modelling of IIT Kanpur substations in the developed ADMS	28
Figure 37:	WSU distribution network during fault	28
Figure 38:	A Game Theoretic Market Framework	29
Figure 39:	A Framework for prosumer market	30
Figure 40:	Different Stages of Market Evolution	30
Figure 41:	Four pillars of DSO formation	32
Figure 42:	Expected vs Metered Load Demand Profile in Rural Pilot	33
Figure 43:	Change in Appliance Ownership	33
Figure 44:	Policies/regulations related to mini/micro grid in India	36
Figure 45:	Policies/regulations related to Energy storage in India	37
Figure 46:	Policies/regulations related to Cyber Security in India	38
Figure 47:	Inputs taken for policy recommendations	38



Figure 48:	(a) Unelectrified Village, (b) Consultation meeting & social survey, (c) Solar Pumps for irrigation needs	42
Figure 49:	(a) Unelectrified Village, (b) Consultation meeting & social survey, (c) Solar Pumps for irrigation needs	42
Figure 50:	Schematic of Semi-urban field pilot	43
Figure 51:	(a) EV Charging station at Type2 community, (b) Schematic of EV Charging Station	43
Figure 52:	Schematic of NETRA Semi-urban field Pilot	44
Figure 53:	(a) TESS installation in IIT Kanpur campus, (b) Peak Load Curtailment by TESS at CESE	45
Figure 54:	(a) Communication Architecture of Urban Field Pilot, (b) HMI screenshot for monitoring	47
Figure 55:	MEMS screen of ADMS application for Rural field Pilot	47
Figure 56:	Schematic of Category-A Pilot by TERI/BRPL	47
Figure 57:	Energy Arbitrage in Category-A Pilot	48
Figure 58:	Schematic of Category-B Pilot by TERI/BRPL	49
Figure 59:	Schematic of Category-C Pilot by TERI/BRPL	49
Figure 60:	(a) Impact of TOD tariff in Category-C Pilot, (b) VPP concept in Category-C Pilot	49
Figure 61:	WSU distribution system with BESS near McCluskey Services building	50
Figure 62:	WSU BESS installation site and network interface architecture	50
Figure 63:	VVC Testing with AVISTA field model using HIL	51
Figure 64:	AVISTA Field Site	52
Figure 65:	US Rural Pilot Site from OPALCO website	52
Figure 66:	UI-ASSIST Lab Pilots	52
Figure 67:	Change in Appliance Ownership	53
Figure 68:	UI-ASSIST Lab Pilots	54
Figure 69:	An integrated microgrid system with various renewable energy sources and storage units	54
Figure 70:	AC-DC Hybrid Microgrid Laboratory test bed.	55
Figure 71:	Overview of the LV distribution system test bed	56
Figure 72:	Testbed for real-time validation of an Anti-Islanding Protection Scheme of IBRs	56
Figure 73:	Architecture of the testbed	56
Figure 74:	TERI Smart Grid Control Lab Test Bed	57
Figure 75:	Federated Testbed, (b) Real time testbed at WSU	58
Figure 76:	OpenDSS and Mininet based CPS co-simulation testbed	58
Figure 77:	HIL testbed block diagram	60
Figure 78:	Custom-developed power monitor with embedded real-time analysis and control capability	60
Figure 79:	Communication architecture	60
Figure 80:	B&McD testbed architecture	61
Figure 81:	NREL testbed	61
Figure 82:	Tested nano grid controller performance testing	62
Figure 83:	Schematic of the n-grid model implemented on Typhoon-HIL	63
Figure 84:	Schematic of the power grid model implemented on RTDS	63
Figure 85:	Schematic of real-time simulators connection	63
Figure 86:	Rural Benchmark System	63
Figure 87:	Schematic of real-time simulators connection	64
Figure 88:	(a) Micro-PMU, (b) Micro-PMU Architecture	65
Figure 89:	DSO White Paper	66
Figure 90:	Summary of the Anticipate, Withstanding and Recover (AWR) Resilience Metric	68
Figure 91:	Overview of the RT-RMS Dataflow Architecture	69
Figure 92:	RT-RMS Console: Pre-event alert mode	69
Figure 93:	Villas interface for federated co-simulation	70
Figure 94:	Future impacts of the UI-ASSIST project	77



Many countries worldwide are deploying significant quantities of renewable sources, specifically solar photovoltaics (PV) and wind plants, for electricity generation to address global environmental and sustainability concerns. The renewable sources are generally converter-interfaced to the grid and have variable outputs depending on the time of day or weather conditions. Hence, energy storage systems are required for the continuity of supply. Other than Renewable Energy Sources (RES) directly connected to distribution systems, microgrids with RES and energy storage are increasingly being deployed not only to provide clean energy access to remote communities, but also to increase resiliency and reliability of supply, and provide flexibility and backup power to the main network. Operation of Smart Distribution Systems integrating microgrids, renewable sources and storage requires suitable designs for control and protection systems. Advanced Distribution Management Systems (ADMS), backed by secure cyber infrastructure, are required to ensure optimal power sharing, storage management, maintaining required power quality and stability of supply.

The main aim of the Indo-US joint project 'UI-ASSIST', involving 31 consortia partners from US and India, was to work on a broad spectrum of required components and sub-systems for the development of smart distribution systems relevant to both countries. The overall task included the required research and development (R&D) activities by the consortia partners, testing and validation of the research work in the lab, and demonstration under different operational challenges in the field. The R&D efforts covered the following aspects of the smart distribution systems.

- 1. Energy Storage:** Modeling, sizing, siting, and optimal charge/discharge control when integrated with the distribution grid.
- 2. Microgrid and Active Distribution System:** Suitable converter topology and its primary control, microgrid modeling, optimal operation, control and protection, and Microgrid Energy Management System (MEMS).
- 3. Cyber Infrastructure and Security:** Different communication options for microgrids and active distribution systems, Cyber-attack simulation and vulnerability assessment, Cyber-physical interdependence analysis, Cyber-security measures, Resiliency and risk analysis, and Cybersecurity audits.

- 4. Advanced Distribution Management System (ADMS)/Distribution System Operator (DSO) Functions:** Sensing and Data Analytics, Optimal operation of Distributed Energy Resources (DERs), RES (solar and wind) and Load forecasting, Volt-Var control, Inertial control, System reconfiguration, reliability assessment, Demand side management, Transmission System Operator (TSO)-DSO interaction and Development of ADMS platform.

- 5. DSO - Market and Regulatory Issues:** Distribution electricity market models, DSO possible models and regulatory aspects, TSO (Transmission System Operator)-DSO interaction, Peer-to-Peer (P2P) trading, Integration of market mechanism into frequency regulation and voltage control.

---

In order to test and validate the above R&D results, lab test beds, six each in India and US, have been setup utilizing DERs & real time simulation facilities, and most of the concepts tested are further implemented in the smart distribution system field demonstration pilots, five each in India and in US, representing Rural (one each in both the countries), Semi-urban (two in each country) and Urban (two in each country) pilots.

To demonstrate the social impact of such systems, pre- as well as post- installation surveys have been carried out. The key findings from the technical R&D activities as well as field deployments in both countries have provided policy and regulatory insights useful to the policy makers, government agencies and utilities. A few benchmark systems have also been developed in the project including a synthetic feeder model benchmark system which will be open to all the researchers for testing the R&D concepts on smart distribution systems. In addition, significant workforce developments in the form of involving students and researchers in the project, training of power professionals from utilities, R&D organizations, and regulatory agencies, have been carried out in the project. The UI-ASSIST project also developed an extensive network for researchers across the US and India for tackling future power system challenges.



This compendium summarizes the key outcomes and deliverables of the UI-ASSIST project resulting from six years of efforts of 31 consortia organizations from India and US. The outcomes of the project are presented under three broad headings - Technical accomplishments, Lab and field level deployments, and highlights of a few major outcomes. Some of the important learnings from the outcomes of the project and recommendations are as follows

- The Battery Energy Storage System (BESS) will be required to be integrated into RES integrated distribution systems with properly designed power management and charge/discharge controls to take care of variability in the output of RESs. Its proper sizing and siting should be carried out considering forecasted load and RES output and network performance objectives.
- Use of BESS in transformer feeders avoids its overloading and can be used for energy arbitrage in such or other community level installations.
- Thermal Energy Storage is a cost-effective and viable option to support air conditioning loads and for peak load shaving.
- Selection of proper DER interfacing converters is important from its efficiency and reliability point of view. Smart inverters with various primary controls such as Maximum Power Point Tracking (MPPT), Q-V support, droop control and fault ride-through capability need to be selected complying with the requirements of the relevant standards.
- Secondary level controls can be ensured through properly designed MEMS to ensure optimal power management from RES and BESS, power quality, grid connected operation, optimal storage management, inertial controls, islanding detection and islanded operation.
- The bidirectional power flow in the smart distribution systems and microgrids requires proper design and coordination of the protection systems. Various possible options include the use of directional relays, impedance measurement-based relaying, and adaptive and intelligent protective schemes.
- Several new technologies, developed and tested in the project, such as Micro-PMU and data driven event analytics for dynamic monitoring of the network, need to be adopted and deployed in the network.
- To take care of operational challenges associated with the RES, storage and electric vehicle (EV) integration into the grid, conventional SCADA based Distribution Management Systems (DMS) need to be upgraded to the ADMS. It should be provided with all the required application functions, such as load and RES output forecasting, state estimation, fault detection, isolation and restoration, Volt-Var control including capability of smart inverters apart from the transformer tap setting, capacitor controls, network reconfiguration, outage management system, and meter data management system.
- The ADMS platform should be developed using an open protocol, provide plug and play feature, Geographical Information System (GIS) interface, and Common Information Model (CIM) based database and must ensure interoperability and flexibility by easily integrating any ADMS module, external source, or third-party apps in the already developed SCADA/ADMS platform.
- To address various challenges arising in the operation of active distribution systems and optimal utilization of DERs, an entity called Distribution System Operator (DSO) will be required. This will help in efficiently utilizing flexible resources available in the distribution system and behind the meter, ensure synergistic interaction with the Transmission System Operator (TSO), facilitate a local electricity market, and assist in identifying optimal network investment decisions. Each distribution utility may decide the appropriate transitioning model to the DSO.
- Distributed and decentralized monitoring and control paradigms need to be further investigated to supplement centralized ADMS for scalable and resilient management strategy with increasing number of RES and IoT (Internet of Things) devices. Also developed DSO architecture needs to consider interface with MEMS, behind-the-meter resources and third-party assets in scalable manner.
- Feasibility study of communication technologies for the active distribution network needs to be undertaken to decide comprehensive action-oriented, easy-to-implement communication options, like LoRa WAN, Narrow Band IoT, GPRS, Wi-Fi, 5G and optic fiber in different sections and settings of the connectivity required.



- The developed cyber infrastructure must be studied for various possible vulnerabilities, cyber-attacks, and their impact and comprehensive mitigation strategies must be developed. A detailed analysis under the existing cybersecurity framework, such as National Institute of Standards and Technology (NIST) or MITRE framework, is required. Some of the suggested measures are securing communication links with time-varying encryption and time stamps, role-based access control for the critical information infrastructure, intrusion detection using cyber-physical data and prevention mechanisms, taking inventory of critical ports and open ports in general, implementation of solid cipher keys, behavioral monitoring to identify anomalies in the network operation, malware entrapment through honeypots or honeynets, cyber audits at the system and device levels, implementation of strict firewall rules, securing patch management system, and creation of cyber-physical resiliency metrics using data from physical systems and cyber-systems.
- To successfully implement Smart Distribution Systems/Microgrids, under different settings, its social acceptance and impact need to be established, which requires pre- as well as post-installation surveys. Apart from technical benefits in terms of ensuring continuous reliable power supply, the impact on education, agriculture yield, and living standards need to be established.
- Holistic validation of developed algorithms, tools and technologies is much needed using end-to-end system models and integrated RES-rich cyber-physical test systems, especially with possible integration of new machine learning algorithms.
- Proper policy and regulatory interventions are required to adopt and wider acceptance of the emerging smart distribution system and mini/micro-grids. Some of the key regulatory recommendations include the following.
  - a) Existing grid codes/regulations need modifications/additions to address new DSO functions and to accommodate modified functions in requisite manner.
  - b) Integration of DERs and digitalization in the distribution network calls for regulations for granular behind-the-meter load and DER output forecasting.
  - c) DSO-TSO Coordination will require data/information and periodicity of exchange.
  - d) Enabling framework for local energy market, community energy market needs to be developed.
  - e) Resource Adequacy for operation planning in consultation with distribution licensee be carried out periodically. There is a need for integrated network planning for next five years.
  - f) Review of regulations required considering the roles and responsibility of various entities for Scheduling and Dispatch functions.
- There is an urgent need for training of utility, regulatory and load dispatch personnels including technicians working in the field on the new technologies and the controls forming part of the smart distribution systems. Regular short/medium term training programs, workshops, and consultation meetings with stakeholders are required. In addition to the existing workforce efforts across the United States and India, the research, development, lab testbed and field demonstration provided early training platforms for the future workforce.





## 2.1 Overview

India and the United States (U.S.) have a long history of successful strategic partnerships, with one of the most notable examples being the energy cooperation. The two countries have consistently deepened their partnership by broadening their collaborative frontiers across several strategic areas in the energy sector. In the Joint Statement issued on June 22, 2023, pursuant to the historic meeting of President Joseph R. Biden, Jr., and Prime Minister Narendra Modi, it was reaffirmed that as climate action and clean energy leaders, the U.S. and India share a common and ambitious vision to rapidly deploy clean energy at scale, build economic prosperity, and help achieve global climate goals. The leaders cited the United States-India Climate and Clean Energy Agenda 2030 Partnership and the Strategic Clean Energy Partnership (SCEP) as examples of this commitment.



## 2.2 Background

Recognizing the need to address climate change, ensure mutual energy security, and build a clean energy economy that drives investment, job creation, and economic growth, India and the U.S. launched the U.S.-India Partnership to Advance Clean Energy (PACE) on November 24, 2009 under the U.S.-India Memorandum of Understanding to Enhance Cooperation on Energy Security, Energy Efficiency, Clean Energy and Climate Change. PACE includes three key components: Research (PACE-R), Deployment (PACE-D), and Off-Grid Energy Access (PEACE).

On November 4, 2010, the U.S. Department of Energy (DOE) and the Government of India executed an agreement to establish the U.S.-India Joint Clean Energy Research and Development Center (JCERDC) under PACE-R. The aim of the program was to facilitate joint research and development on clean energy technologies that can be deployed rapidly with the greatest impact. The JCERDC was based on a public-private partnership model of funding and was a first-of-its-kind initiative that brought together more than 100 Indian and American academic and industrial partners to work jointly in the space of clean energy research.

The Indo-U.S. Science and Technology Forum (IUSSTF) in New Delhi serves as the Indian Secretariat, while the DOE's Office of International Affairs in Washington, DC acts as the DOE's Secretariat.

During Phase I of the Joint Clean Energy Research and Development Center (JCERDC) Solar Energy, Second Generation Biofuels, and Building Energy Efficiency were the three key areas for collaboration funded during the first phase of the JCERDC. The projects were implemented from 2012 until 2017. A snapshot of the project is given below:

- The vision of the Solar Energy Research Institute for India and the United States (SERIIUS), co-led by the Indian Institute of Science at Bangalore (IISc) and the National Renewable Energy Laboratory (NREL), was to create an environment for cooperation and innovation “without borders” to develop and ready emerging and revolutionary solar electricity technologies for long-term success of India’s Jawaharlal Nehru National Solar Energy Mission and the U.S. DOE SunShot Initiative.



- The U.S.-India Joint Centre for Building Energy Research and Development (CBERD), co-led by CEPT University-Ahmedabad and the Lawrence Berkeley National Laboratory, was engaged in collaborative research and innovation in the area of energy efficiency in buildings with measurable results and targeted a significant reduction in energy use in the U.S. and India. CBERD focused on the integration of information technology with building physical system technology in commercial and multi-family residential high-rise buildings.
- The U.S.-India Consortium for Development of Sustainable Advanced Lignocellulosic Biofuel Systems (SALBS), co-led by the Indian Institute of Chemical Technology-Hyderabad and the University of Florida-Gainesville, collaborated to work on sustainable feedstock cultivation and supply, biochemical conversion technologies for production of second-generation biofuels with minimal environmental impact, and analysis of overall sustainability and supply chain of feedstock

Under these thematic initiatives, researchers from academia, industry, and policymakers from India and the U.S. collaborated to create a knowledge-sharing ecosystem. The model was proven to be extraordinarily successful. These projects not only generated outstanding technical outcomes, research publications, and capacity building but also helped guide policy issues. The JCERDC Phase I consortia brought together numerous academic institutes, laboratories, and enterprises, resulting in the development of multiple collaborative groups that continued to progress the partnership even after the projects concluded successfully.

Recognizing the success of Phase I of the JCERDC, both countries agreed to broaden the "Partnership to Advance Clean Energy Research (PACE-R)" to two new research areas critical to improving the reliability, flexibility, and efficiency of the electricity delivery system: Smart Grid and Energy Storage.

Following which, the "UI-ASSIST: U.S.-India collABorative for smart diStribution System wIth Storage" project, co-led by the Indian Institute of Technology, Kanpur and Washington State University, Pullman was awarded in September 2017 through a multilevel review process.

The Government of India and the U.S. DOE, each budgeted \$1.5 million (INR 10.2 crore) annually for the consortium over the five-year duration of the project.



Electric power sector, specifically the distribution sector, across the globe has been witnessing fast changes in terms of new types of sources and interfacing devices being added, large deployment of sensors, smart meters, and ICT (Information and Communications Technology) infrastructure. In the past, the distribution networks have been mostly passive and had radial structure receiving power from sub-transmission or transmission grid and making it available to the consumers and had minimal ICT infrastructure, as shown in Figure 1.

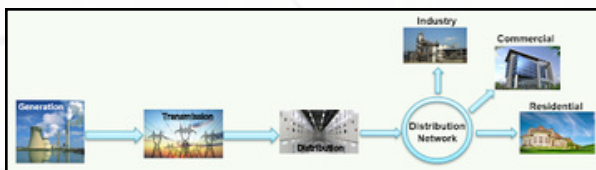

Figure 1: Conventional Electric Grid (Source: Internet)

The power flows in the network have been unidirectional. Bulk of the generation capacity has been fossil fuel based. In order to address the global environmental/climate change concerns, Renewable Energy Sources (RESs) are being increasingly added in the transmission as well as distribution networks/consumer premises, predominantly the Solar Photovoltaics (SPV) and Wind plants. Addition of such distributed energy sources causes the network power flow to become bidirectional. For better management of such evolving systems, large number of sensors across the network, bidirectional communication networks and decision-making tools are required to be added, that will result in transition of the conventional grid into the Smart Grid, as shown in Figure 2.

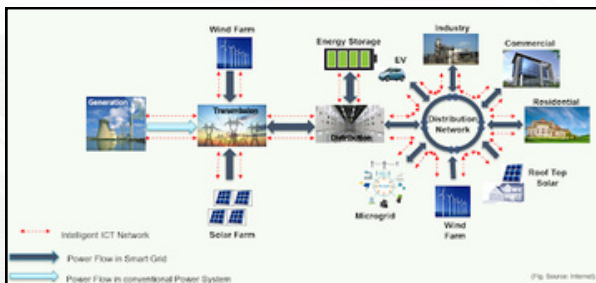

Figure 2: Typical Smart Electric Grid

Many countries worldwide have set ambitious target for the addition of renewable energy sources, including India and US. India had set a target of adding 175 GW of RESs by 2022 including 100 GW of the SPV, and now wishes to take the RES installation to 450 GW by 2030 with dominant share from the SPV. It is expected that almost 40% of the SPV installation will be on rooftops, mostly connected to the distribution network, and the remaining will be ground mounted. The US also has plans for significant addition of the SPV and wind plants, specifically in states like California, Arizona, New Jersey, and Texas. Both solar PV and wind plants have variable/intermittent outputs that depend on wind speed, solar irradiance, cloud conditions and time of the day. To maintain continuity of supply to the loads, apart from flexible generation, energy storage systems are required. Amongst various available options, Battery Energy Storage System (BESS) is more viable, specifically at distribution level.

The concept of microgrids is being promoted in many countries, including India and US, to provide reliable supply to remote areas, strategic locations, community level, industrial as well as commercial complexes. Recent drive for increasing Electric Vehicles (EV) for transportation will require a large number of charging stations to be connected to the distribution grid adding more complexity and stress in its operation. Some of the distribution utilities in India and many in US had already installed Supervisory Control and Data Acquisition (SCADA) system and Distribution Management System (DMS) with required communication network, primarily for monitoring of the system states. Large deployment of RES, storage and microgrids as well as EV infrastructure will require the development and deployment of Advanced Distribution Management System (ADMS) and, in future, the Distribution System Operator (DSO) concepts. Large numbers of sensors, meters, automation devices, and cyber infrastructure need to be added to acquire system wide data and for effective operation and management of the system. Addition of distributed energy resources (DERs), automation and cyber infrastructure also poses challenges to the resiliency/cybersecurity of the system, which need to be addressed.



Based on the above expected fast developments in the distribution networks, the call for proposals under phase-2 of the JCERDC scheme, announced in August 2016, had been on 'Smart Grid and Storage' theme relevant to the smart distribution systems. The US-India collaborative for smart diStribution System wIth STorage (UI-ASSIST) project, led by Washington State University (WSU) and funded by Department of Energy (DOE) on US side, and Indian Institute of Technology Kanpur (IITK) and funded by Department of Science and Technology (DST) through Indo-US Science and Technology Forum (IUSSTF) on India side, was selected under this scheme.

The US-India team of 31 organizations, 16 from US and 15 from India, behind the UI-ASSIST proposal represents some of the strongest universities/institutes, national laboratories, electrical utilities, and industries in the field of clean energy, each of which has an established track record of contributing to the significant changes already occurring in electric distribution system. As the India and US partners had different and often complementary expertise, it was imperative to have a strong collaborative effort across the countries and researchers. A few of them are listed below.

- Although the technical R&D needed for the future distribution grid in both countries is similar, India's high electric load growth has been projected to continue in future and the decarbonization of its resources will occur while rapidly increasing generation capacity. In contrast, the load growth in the US is modest and the decarbonization strategy is mostly replacing present generation capacity with distributed renewable resources. This difference was recognized in the project by integrating into the proposed research in terms of societal value and technology impact, anticipating that the policies adopted in the two countries may be different.
- Both within the US and in urban parts of India, the challenge within the distribution systems has been in integrating storage and DERs control with Micro Energy Management System ( $\mu$ EMS) and tools for the operation of distribution systems, which could be understood, explored, and developed in collaborative manner.

- US national labs and several of the industry partners involved in the consortia had already state of art facilities for testing renewable integration concepts, storage model development and testing, whereas in India it was required to develop these facilities.
- Most of the distribution utilities had already gone for SCADA and DMS in their systems in US, whereas with government's reforms program, very few were being installed by utilities in India.
- Advanced Distribution Management System (ADMS) concept was at advanced stage of development and adoption in US, whereas it was to be developed and tested in Indian context.
- India team had relatively strong experience in interfacing converter development and controls and also in analytics.
- US team had better understanding of the cybersecurity/resiliency concepts relevant to smart grids.
- India offered larger and diverse opportunity for field deployment, with the smart distribution system concept being at nascent stage, which will offer opportunity to US team to advance with a global perspective.
- Both US and Indian governments are having initiatives towards low carbon economies that could be demonstrated jointly through this project.

It was envisaged that the two teams will leverage the strengths of each other and emerge as strong UI-ASSIST team to jointly contribute to the research and innovation required to achieve the project objectives.

The unique feature of the UI-ASSIST project has been working on almost all required components for development and demonstration of RES, storage and microgrid integrated smart distribution systems relevant to both the countries. The overall task included carrying out the required R&D activities by the consortia partners, testing and validation of the research work in the lab, and demonstrating under different settings in the field. The R&D efforts have been aimed at the following aspects of the smart distribution systems.



1. Energy Storage: Modeling, sizing, siting, and optimal charge/discharge control when integrated with the distribution grid.
2. Microgrid and Active Distribution System: Suitable converter topology and its primary control, microgrid modeling, optimal operation, control and protection, Microgrid Energy Management system.
3. Cyber Infrastructure and Security: Different communication options for microgrids and active distribution systems, Cyber-attack simulation and vulnerability assessment, Cyber-physical interdependence analysis and Cyber-security measures, Resiliency and risk analysis, Cybersecurity audit.
4. Advanced Distribution Management System (ADMS)/DSO Functions: Sensing and Data Analytics, Optimal operation of Distributed Energy Resources (DERs), RES (solar and wind) and Load forecasting, Volt-Var control, Inertial control, System reconfiguration, reliability assessment, Demand side management, TSO-DSO interaction; Development of ADMS platform.
5. DSO - Market and Regulatory Issues: Distribution electricity market models, DSO possible models and regulatory aspects, TSO-DSO interaction, P2P trading, Integration of market mechanism into frequency regulation and voltage control.

In order to test and validate the above R&D results, six lab test beds in India and US were to be setup utilizing real time simulation facilities, and most of the concepts tested were to be further implemented in the five demonstration pilots each in India as well in US, representing Rural, Semi-urban and Urban smart distribution system pilots. In order to demonstrate the social impact of such systems, pre- as well as post-installation surveys were planned. The key findings from the technical R&D activities as well as field deployments in both the countries were envisaged to provide policy and regulatory insights useful to the policy makers/government agencies for larger deployments of such systems.

The project also aimed at developing a few benchmark systems including a synthetic benchmark system which will be open to all the researchers for testing the R&D concepts on smart distribution systems. In addition, workforce development in the form of involving students and researchers in the project, training of power professionals from utilities, R&D organizations and regulatory agencies, have been included in the project.

The UI-ASSIST project has been led by Indian Institute of Technology Kanpur from India with Dr. Ankush Sharma and Dr. Abheejeet Mohapatra from its Electrical Engineering department being the India lead and co-Lead, respectively (Dr. Suresh Chandra Srivastava and Dr. Santanu Mishra being the earlier leads), whereas it has been led by the Washington State University Pullman from US with Dr. Noel N. Schulz from ECE Department being the US Administrative Lead, and Dr. Anurag Kumar Srivastava (who moved to West Virginia University), and Dr. Sanjeev Panala being the Technical co-Leads. A list of all the consortia partner researchers is given in the Appendix.

---

## 4.1 Purpose

The overall goal of the UI-ASSIST project has been to develop and demonstrate the Active Distribution System concept for optimal utilization and management of DERs by interfacing with their controls and microgrid control system along with penetration of energy storage systems. In meeting this objective, the project also aims at addressing communication needs; data needs; security, including cybersecurity; economy and resiliency issues; social issues; workforce requirements; policy recommendations; and suitable DSO functions considering seamless integration of DERs, MEMS and DMS functions.

## 4.2 Activities

The UI-ASSIST project addresses essential issues related to the adoption and deployment of smart grid concepts and integrating distributed energy resources including storage in the distribution network and at microgrid level, for its efficient and reliable operation.

Research and Development (R&D) work focused on five broad thematic areas (labeled as 3 to 7 in the Figure 3).

The research work included optimal siting, sizing and control of energy storage system at microgrid and feeder levels; development of suitable converter topologies along with primary controls to integrate renewable sources, storage systems, and also for integration of microgrids to the main grid; secondary controls development for coordinated power management and control at microgrid level through Microgrid Energy Management System ( $\mu$ EMS); developing protection system schemes within microgrid as well as distribution network levels for detecting and locating the fault, islanding detection and adaptive settings; load, solar and wind forecasting tools; various Advanced Distribution Management System (ADMS) functions include areas such as state estimation, volt-var management, optimal reconfiguration, optimal power scheduling in presence of Distributed Energy Resources (DERs), demand side management, transactive controls, and integrating market based signals required to be performed by Distribution System Operators (DSOs) in future. To make system intelligent and smart, R&D work on exploring various disruptive communication technologies, new protocols, IoT integration issues, communication network issues in controls, cyber threat detection and cybersecurity measures were also carried out.

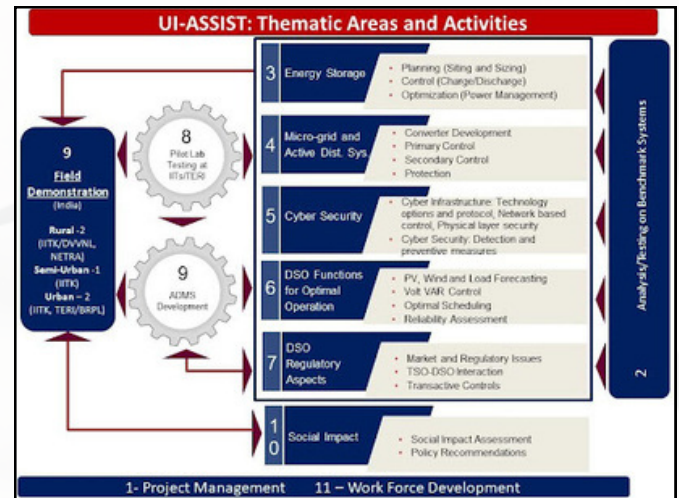

Figure 3: UI-ASSIST Thematic Areas and Activities

A synthetic benchmark system by US team and several systems utilizing pilot/utility data by India and US teams, representing evolving microgrids and future distribution networks, were developed. Most of the R&D concepts are tested and validated through offline and online simulations at the lab levels in six laboratory testbeds each in India and US.

The evolving microgrid and advanced distribution system concepts were demonstrated in actual field implementations. For this purpose, one rural, two semi-urban and two urban pilots in India, and one rural, two semi-urban and two urban pilots in US were set up. The research work also focused on societal and policy/regulatory issues, aimed at providing a set of recommendations for successful adoption of such systems.

## 4.3 Technical Accomplishments

One of the major components of the UI-ASSIST project was to carry our R&D activities required in almost all the thematic areas of the smart distribution system. Key technical R&D accomplishments in each of these are briefly described below.

### 4.3.1 Energy Storage

#### Overview

In order to make the future distribution grid sustainable while enabling the increasing penetration of Distributed Energy Resources (DERs), energy storage integration is a key requirement. The presence of energy storage mitigates the effect of uncertainty associated with the distributed energy resources and makes the system dispatchable and reliable. Within the scope of UI-ASSIST, a comprehensive evaluation of practical aspects of energy storage integration within distribution systems has been carried out. As part of the project, storage integration challenges in each of the Urban, Semi-Urban and Rural distribution systems were evaluated.

#### Key activities undertaken.

**Identification and selection of sites** for storage integration in distribution systems were performed pertaining to Indian scenario. Sites of demonstration have been identified for Urban, Semi-Urban, and Rural demonstrations considering the feasibility, techno-economic, and societal aspects in each of the locations

#### A - Optimal placement and sizing of BESS for TERI & BRPL urban pilots

Integration of BESS in urban scenarios has been considered at the following sites with different applications:

- a) New Friends Colony at Taimoor Nagar in New Delhi (denoted as Cat A, implemented by TERI and BRPL) demonstrates the integration of grid-scale BESS for a selected distribution/ LT feeder which is serving residential customers.
- b) Ispatika Apartments at Dwarka, New Delhi (denoted as Cat B, implemented by TERI and BRPL) demonstrates grid-scale BESS integration for a selected group housing society/ gated community having roof-top solar PV power plants installed.
- c) TERI School of Advanced Studies building in Vasant Kunj, New Delhi (denoted as Cat C, implemented by TERI and BRPL) demonstrates the impact of storage on an institutional area. This location was selected to study the impact of time-of-day tariff on consumers’ usage and was a potential site for implementation of Virtual Power Plant (VPP) and Vehicle-to-Grid (V2G) concepts.

Li-ion battery storage was identified for evaluation at each of the pilot sites.

- **Battery sizing and siting** is a crucial step towards setting up a Battery Energy Storage System at a given location. The requirements at each of the sites are dependent upon the nature of the system, type of load and the applications of BESS. Typically, historical load data forms the basis for the design and finalization of BESS capacity. As an example, for Cat A system, historical load data provided by the BRPL for the Distribution Transformer (DT) and feeder were studied for the period from 2015 to 2017. Other parameters considered were projected load growth and projected penetration of solar PV. Figure 4 shows battery sizing methodology adopted.
- **Identification of primary and secondary objectives of BESS:** Each of the BESS systems used in urban scenario can be associated with a primary and a secondary objective to enhance the functionality of the system. The following primary and secondary objectives have been identified for the pilot projects undertaken by TERI.

Pilot Site	Primary objective	Secondary objective
Category A	Peak load shaving of distribution transformer	Energy Arbitrage
Category B	Backup power supply	Energy Arbitrage
Category C	Energy arbitrage	Virtual power plant

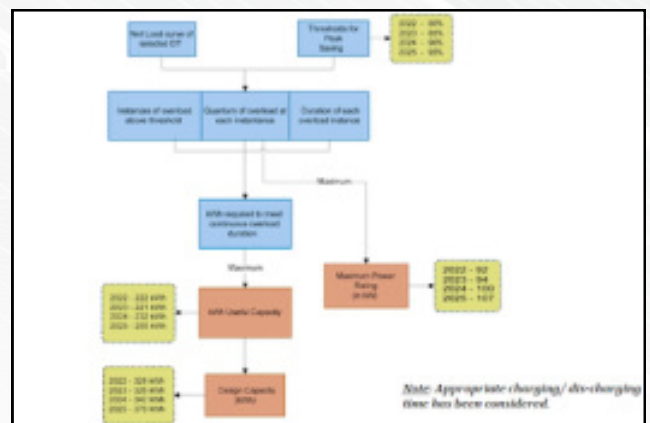

Figure 4: Battery sizing methodology for DT peak shaving application (Cat A-TERI & BRPL pilot)

## • Development of control algorithms for optimal utilization of BESS

The development of control schemes has been carried out for the different systems being studied under the project. The key accomplishments are given below.

- Development of intelligent algorithms for SOC estimation of BESS.
- Control algorithm development for implementation of primary and secondary functions of BESS.
- Development of forecasting methods for optimal utilization of storage.

### Study of impact of BESS on loss of life and health monitoring of equipment.

The objective of the study was to develop a predefined (day-ahead) control algorithm for battery charging and discharging in such a way that the operations of BESS could be optimized and reduce the distribution transformers loss of life (LoL), thus extend the service life of transformer.

## B - Optimal placement and sizing of BESS for IITK semiurban pilot

Optimal BESS placement and sizing was performed for the semi-urban microgrid system utilizing distribution network in two of the residential lanes having single story houses inside the IITK campus, forming a ring and fed from a common 11kV/415V substation. The **Error! Reference source not found.** below shows the layout of this system. The optimal sizing and siting of the BESS was obtained by solving an optimization problem that minimizes the normalized value of the total real power loss and voltage deviation. Seven possible locations of battery storage were initially identified out of which two were not considered due to space unavailability. The optimization problem was solved for all the five cases and the best location found was at feeder pillars FP-1b and 2b in lanes 32 and 33, respectively followed by the second best at the two feeders emanating at the substation. Due to increased cable length for interconnecting storage at FP-1b and 2b with the switchgears, and for ease of operation and maintenance, these were not considered. The second best option at substation was considered for the storage deployment.

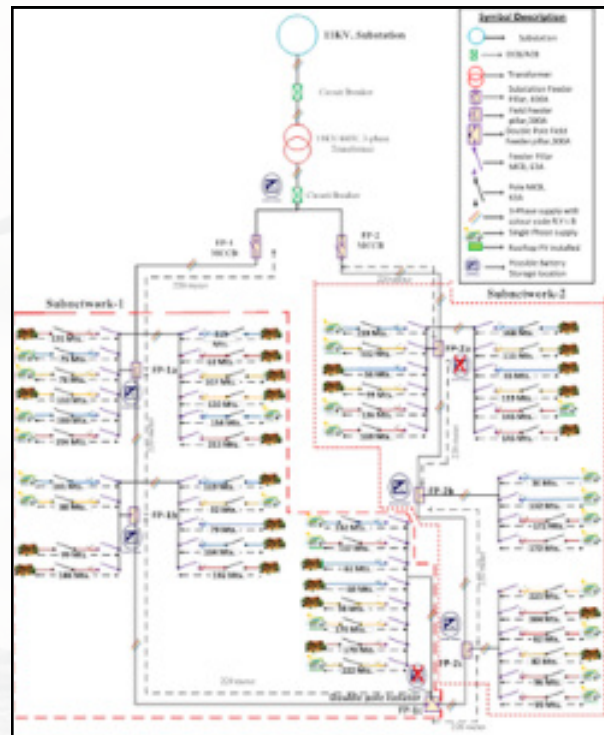

Figure 5: Semi-urban AC microgrid distribution system at IIT Kanpur campus

## C - WSU Field Pilot Storage Model Selection and Sizing

First, selection of storage types for the WSU semi-urban pilot was conducted by understanding the project specific requirements and use cases. Li-ion battery energy storage system was finalized by performing the impact analysis to support its field demo and real-time simulations of storage model were performed using the WSU campus feeder model.

- Modeling and analysis of storage** was undertaken considering electrical equivalent models of storage. The modeling of storage was carried out both at cell level and at system level (see Figure 6). Multi-cell behavior has been studied to observe the impact of unequal SOC which brings the importance of battery management systems for charge balancing. The storage system has been modeled at the system level to study the impact of BESS on the overall system. Different methods for estimation of the state of charge (SOC) of battery have been investigated.

- A methodology for producing energy storage system performance models was developed with data received from utilities in the State of Washington. Using BESS data from SnoPUD Arlington Microgrid, development of BESS performance/reliability modeling was carried out. PNNL generated methodology for scaling BESS models to BESS systems of different rated energy and power were used along with validation of methodology, allowing prediction of performance before deployment. Further, collaborative modeling work involved a modified Li-LFP ESS model to implement model of a 154-kWh system for India rural pilot. Modeling philosophy of storage model is shown in Figure 7.

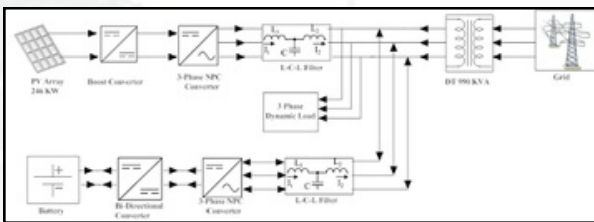

Figure 6: System level modelling of BESS for WSU Urban distribution system

- An equivalent circuit model of BESS was developed that was utilized for estimating SOC and parameters for a secondary battery. Recursive least squares method-based parameter estimation was successful in simulations. A machine learning-based procedure for state and parameter estimation using an ANCF-e model was developed for lithium-ion batteries and focused on estimating nonlinearity in models

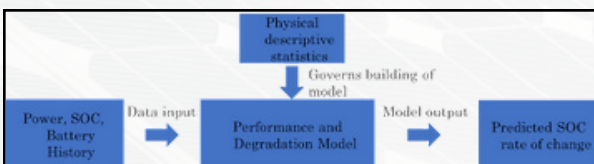

Figure 7: Storage Modeling Philosophy

## Storage System Optimization

- Development of initial case-studies for modeling energy storage value streams in DER-CAM was completed. Report outlining case-studies, and case-study model files will be made available for different project applications. The US Team furthered development of storage dispatch and optimization algorithm for storage value streams: demand management, resilience, and ancillary services. DER-CAM tool was updated to improve sharing and uploading of modeling resources (case-study models) produced previously and refined case-study model list to utilize latest model format and features. One case study of storage systems is demonstrated in Figure 8

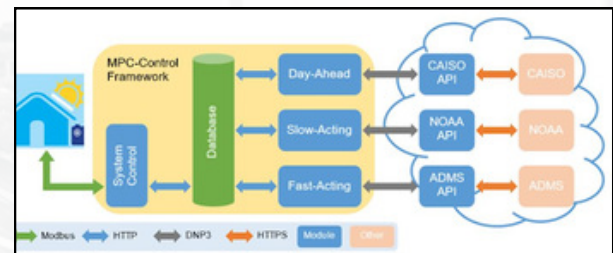

Figure 8: Value Stream Analysis of Storage systems

## Electric Vehicle Storage Systems

- A controller was developed for managing the charging of EVs in buildings with large parking facilities. The method was deployed to evaluate the loss of life and failure risk of the transformer that is feeding a building with a large parking lot. One-year use case scenarios developed to demonstrate the benefits of the proposed management system using real and synthesized data. The use case test results showed that the proposed approach could effectively reduce the probability of transformer failure by managing delays in EV charging and paying incentives to the EV owners in return. Further, the team completed linearization of transformer's failure and ageing equations in order to optimize the charging of stationary battery energy storage systems.

## D - Impact of thermal energy storage system in urban distribution

The impact of alternate storage technology has been investigated on the IIT Kanpur distribution system using thermal energy storage system. A thermal energy storage (TES) system with total capacity of 775 TR HR has been installed in the "Centre for Environmental Science and Engineering (CESE)" building within the IIT Kanpur campus. TES systems provide several advantages for office and institutional buildings, especially those with low power demand during nighttime. The installed TES system utilizes phase change material and a Brine solution as a coolant. The TES system size was arrived looking at the peak air-conditioning load of the CESE building, which is 150 Ton. It was assumed that the TES system, which can be charged during off peak load hours in the night utilizing chilled water supply from the central air-conditioning plant can support peak air-conditioning requirement of the building for 5 hours or average load of 75 Ton for 10 hours during the daytime peak load period. Figure 9 shows the 545 TR HR TES system external tank. Another 230 TR HR TES system installed is having underground tank.



Figure 9: Thermal Energy Storage System Horizontal Outside Tank

### Takeaways from work on Energy Storage

The activities under energy storage are related to the following major activities under UI-ASSIST.

Few specific takeaways under Energy Storage activities are as follows:

- Equivalent storage cell model and performance models were developed, and further fine-tuned with field and simulated data to improve them as a more practical and realistic representation.

- Optimal selection and sizing of storage systems were carried out for pilot projects with different applications.
- Electric Vehicle storage optimization models were developed.

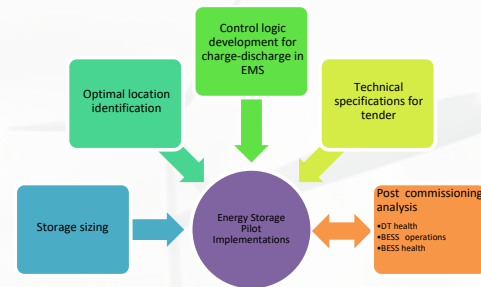

Figure 10: Activities of Energy Storage Systems under UI-ASSIST

## 4.3.2 Microgrid and Active Distribution System Key issues & challenges

With the rapid integration of Distributed Energy Resources (DERs), mostly inverter interfaced, the Electric Distribution Network (EDN) is becoming an active entity. As per IEEE Std. 2030.7 on Specification of Microgrid Controllers, a microgrid is defined as 'A group of interconnected loads and distributed energy resources with clearly defined electrical boundaries that acts as a single controllable entity with respect to the grid and can connect and disconnect from the grid to enable it to operate in both grid-connected or islanded modes'.

A typical microgrid system, as shown in Figure 11, may consist of PV systems, wind energy systems, fuel cells, biomass plants, etc., as DERs, different types of interfacing converters, such as dc-dc or dc-ac converters, Voltage Source Converters (VSCs), and energy storage units, such as batteries and supercapacitors. Alternatively, due to the dissimilar electrical characteristics of different types of sources and energy storage elements, power electronics-based converters, such as VSCs, are included between each source/storage and the microgrid. The microgrid can be connected to the main ac grid through VSCs. The VSC operates both in inverter as well as rectifier mode depending upon the power flow. VSCs may be required to operate to address power quality issues in addition to the real power transfer from the renewables to the grid or to feed the local load at the ac as well as dc bus.



To control the current and voltage output of these converters by suitably modulating the power semiconductor devices, primary controllers are used. These controllers include current control, voltage control and droop control. The droop control allows parallel connection of converters within the microgrid. Due to cable / interconnecting lines and difference in characteristics of sources, power shared by the sources is not proportional. To address this issue, along with ensuring good voltage regulation, secondary controllers are used. These controllers are responsible for maintaining power quality within the microgrid. In case of any abnormal behavior or fault in the system, suitable protection mechanism is required for detection, location identification, and isolation of the faulty section. Bidirectional power flow, limited fault current and high current rise time are some of the issues that need to be handled while developing appropriate protection mechanisms.

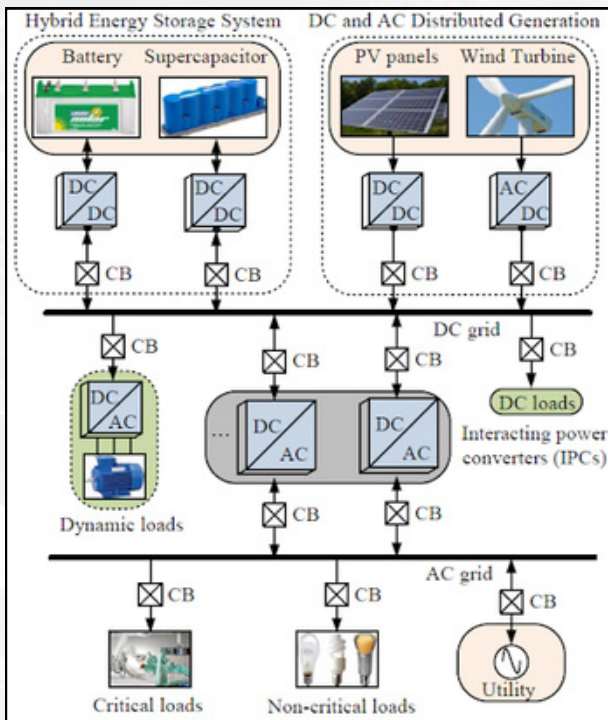

Figure 11: A general structure of a microgrid system

## Major R&D Efforts

To address the above key challenges in operation, control, and protection of microgrids and active EDNs, the key R&D activities, which have been done, are summarized in Figure 12. These broadly include efforts on

1. Development of power electronics-based converters and associated topologies for proper integration of sources within the microgrid
2. Design of primary and secondary controllers for power management
3. Development and testing of AC/DC microgrid protective schemes.

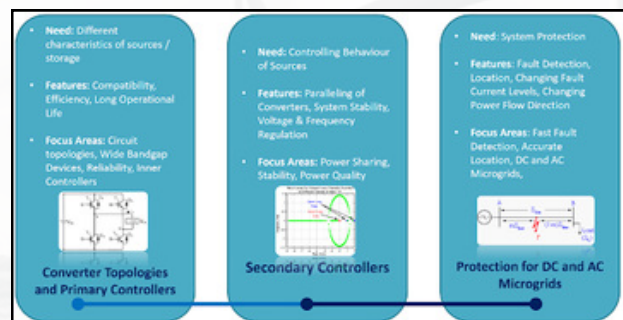

Figure 12: Focus of key R&D activities in microgrids and active EDNs

Summary of few representative R&D activities which have been done as part of this project on multiple dimensions of microgrid operation, control and protection are discussed below.

## Summary of R&D Activities

A comprehensive summary of few major findings of the research activities in each of the above pivotal areas is as follows:

### Design and development of converters with associated primary and secondary controllers:

**Design and development of converters with associated primary and secondary controllers:** Power quality is a major concern in connected microgrid with integrated storage and has been analyzed at length. Sliding Mode Control (SMC) is extensively used as a primary controller for Distribution Static Compensators (DSTATCOMs) to improve power quality. In the conventional SMC, the four-leg DSTATCOM currents are controlled based on a current error in each phase. However, the four currents in a four-wire system cannot be independently controlled variables, and hence one of the four controllers is redundant in conventional schemes.

As a key research output, a new scheme is proposed as shown in Figure 13, in which the current due to the Thevenin's equivalent load neutral-point voltage is considered as a fourth independent controlled variable and the corresponding system dynamic equations are presented. To get a decoupled feature, a new sliding surface function is structured. The performance of a DSTATCOM with the proposed control scheme under various operating conditions is validated through a detailed simulation study and experimental results, obtained from a laboratory prototype of four-leg DSTATCOM. Integration of storage elements in a microgrid has also been on the focus. A circuit with battery and supercapacitor combination is also designed to effectively achieve DC link voltage restoration in inverters for microgrids. Additionally, a novel centralized power management control strategy is proposed for a hybrid microgrid with parallel grid converters as shown in Figure 14. An improved version of instantaneous symmetrical component theory was developed and used for control of parallel operated grid converters, which results in reduced sensor requirement, control complexity, and communication bandwidth. In addition, a simple power management algorithm was developed to test efficacy of the parallel grid side converter control strategy for all the microgrid modes considering various operating conditions.

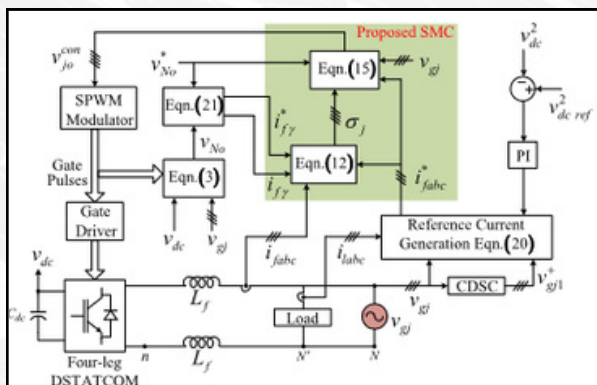

Figure 13: Block diagram of the SMC control scheme as primary controller

Figure 15 shows a solar PV based DER connected to the grid via an LC filter and isolation transformer. A transformer is used as a direct solution to grounding and leakage current problems. This transformer can be utilized to provide voltage amplification. The AC side control consists of two control loops, viz., outer voltage and inner current loop. The outer voltage loop is a feed-forward structure and was implemented to maintain the DC link voltage constant.

This voltage loop has slower dynamics compared to the current loop and produces a reference for the inner current loop. The current loop has fast dynamics and is responsible for grid interactions. Hence, control of reactive power, power quality requirements, and protection of system are objectives of this inner current loop. Typically, in synchronous reference frame controller, two Proportional Integral (PI) controllers will suffice.

The DC link voltage controller is used to maintain a constant DC link voltage. This ensures that the maximum power extracted by the DC-DC converter is completely fed into the grid, obeying capacitor charge balance. Note that there is no external power reference ( $P^*$ ) in the case of grid feeding PV systems as the power fed into the grid is decided by the MPPT controller. Typically, a PI controller is used as the DC link voltage controller. Various other secondary control schemes with reduced communication requirements have also been developed with local averaging of quantities, as shown in Figure 16. A comparison was made with the distributed secondary controller employing full communication and reduced communication. The performance of the system with reduced communication was the same as that of one with full communication.

The development of enhanced primary and inner control algorithms for converter-based AC and DC microgrids is also carried out, as illustrated in Figure 17. Key issues in this process include low X/R ratio, unbalanced network and loads and weak grid scenario. Impact of control actions on performance for transient disturbances such as faults, islanding was also being analyzed.

Converter response during faults, islanding detection methodologies and conflicts of grid-code compliance are the issues addressed here. A robust customer end voltage control for DC microgrids was also developed. The proposed back stepping controller implemented memory less, instantaneous state feedback. The resultant control action was simply obtained by linear combination of states and reference set-points and does not add extra dynamics into the system avoiding complexity. The proposed method does not require load current measurement and the cost of current sensor is curtailed economically. The impact of unintentional islanding on inverter-based resources enabled with reactive power allocation and frequency dependent active power curtailment services has also been analyzed.

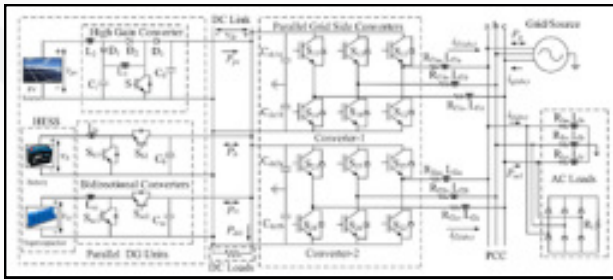

Figure 14: Proposed hybrid microgrid structure

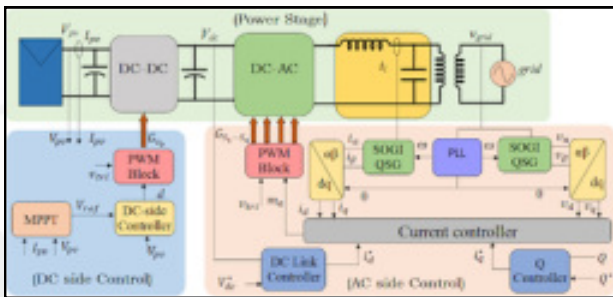

Figure 15: Complete control architecture of a solar PV based DER connected to the main AC grid.



Figure 16: Development of secondary controllers with (a) full communication, and (b) reduced communication.

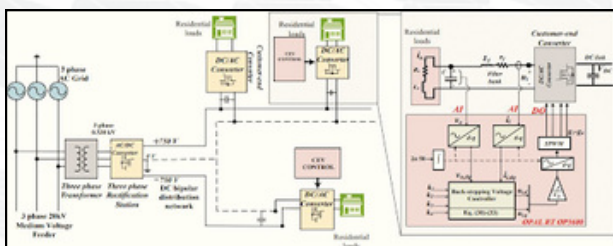

Figure 17: Field test environment for LV DC distribution implementation

## Conceptualizing Rural DC Microgrids

Millions of people around the globe are suffering from energy poverty, particularly the inhabitants of Africa and South-East Asia. Electrification through national grids is cost-prohibitive with limited power generation sources in the third world countries. The low-voltage, low-power islanded DC microgrids can be one of the practical options for rural electrification.

A detailed network loss analysis of four different microgrid architectures is performed using the modified Newton-Raphson power flow for DC systems. These architectures include, 1) Centralized generation centralized storage (CGCS), 2) Centralized generation distributed storage (CGDS), 3) Distributed generation centralized storage (DGCS), and 4) Distributed generation distributed storage (DGDS), which are implemented with both radial and ring interconnection schemes using time-varying load demand and dynamic PV generation. Figure 18 shows two of the architectures. The comparative analysis on these architectures was performed with multiple conductor sizes and different low-voltage levels which indicated that distributed architecture with ring interconnection was more efficient and reliable in comparison to other architectures and interconnection schemes due to its high efficiency, low voltage drop, and reduced distribution losses. This analysis will be useful in optimal planning and designing of new and upgrading of existing low voltage DC (LVDC) microgrid systems.

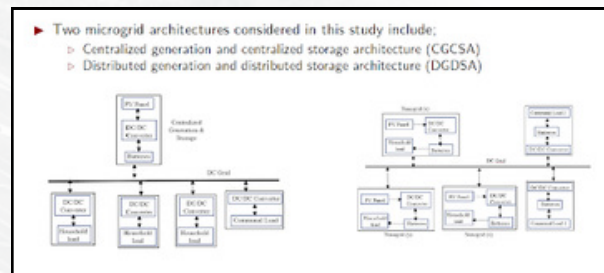

Figure 18: Two different architectures of rural DC grids: 1) Centralized generation centralized storage (Left side), 4) Distributed generation distributed storage (Right side).

## Microgrid control and management systems

- US and India teams collaborated on an effective control and management scheme of Isolated DC Microgrids. The Isolated DC microgrid consists of an internal power management scheme (PMS) responsible for effective power sharing (primary and secondary level controls) among distributed energy resources like diesel generator, photovoltaic panel, battery, and supercapacitors which is shown in Figure 19. Additionally, when integrated to the grid, the Microgrid is enabled to assist the distribution utility for uniform voltage regulation in the distribution feeder. This was achieved through a coordinated control strategy between the Advanced Distribution Management System (ADMS) of the utility and the Microgrid Management System ( $\mu$ EMS) of the DC microgrid.

- Microgrid clusters were developed in the real time digital simulator (RTDS), for validation of centralized and consensus-based control approaches from both US and India teams. These two clusters were connected to an IEEE 13 node distribution system for making the modified benchmark model as one of use cases in validating two-layer volt-var control methodology.
- US and India teams worked together on MPC (Model Predictive Control) based centralized single step and sequential restoration algorithm to optimize load restoration. They also tested the efficiency of the algorithm for large test systems and proposed worst-case/robust MPC based sequential restoration scheme to include uncertainty associated to generation and demand. Further, the teams developed a decomposable restoration model for fully distributed alternating direction method of multipliers (ADMM) based restoration algorithm and this can incorporate multiple slack buses / grids forming buses in a distribution grid. The proposed mixed integer ADMM method was compared with existing methods and proved the autonomous capability of the algorithm.

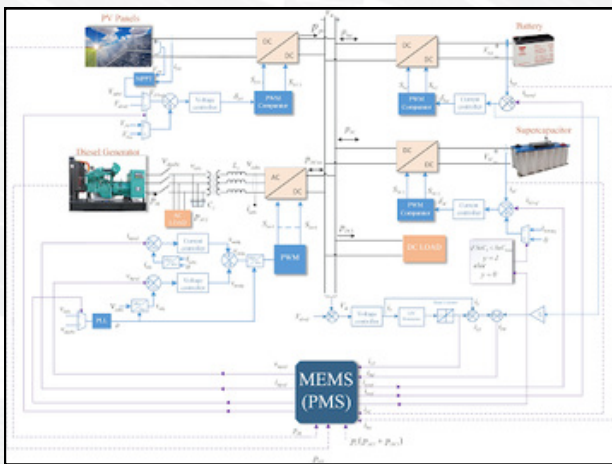

Figure 19: DC microgrid architecture with control mechanism under islanded mode.

- US partners collaborated to extend application of MIT's PAC algorithm in weakly meshed distributed networks for distributed restoration scheme. It includes integral relaxation and rounding technique to operate PAC for network restoration.
- US team worked on Microgrid feasibility study for Tulalip Tribes considering the solar PV and BESS.

- Under the development of networked microgrid (MG) system, the network was partitioned into multiple MGs based on the grid conditions. For example, in case a substation is not available due to damage caused by high impact natural events, the distribution grid with the MG formation capability is divided into multiple MGs to retain continuity of power supply. Based on the capability of grid forming DGs, decision making happens in the ADMS to form MGs. The number of MGs formed is independent of the number of grid forming DGs. The energy management system of a MG ( $\mu$ EMS) ensures stable and reliable operation of a MG. An MPC controller developed by US team can perform the same task optimally if an objective function and operation constraints are properly defined. For the predicted states of a system, MPC proposes the trajectory of the inputs to achieve desirable outputs. This MPC based  $\mu$ EMS strategy will work along with the restoration scheme of ADMS for proactive-service restoration of distribution grid.

### Distribution and Microgrid Grid Protection

- US and India teams collaborated on examination of the impact of Distributed Generators (DGs) penetration on short circuit capacity and bidirectional power flow analysis of unnecessary tripping and sympathetic tripping phenomena. Next, they investigated unintentional islanding and the challenges of integrating different types of DGs. This led to the recommendations for potential protection measures and adaptive relaying schemes for improved performance in microgrids. Overview of collaboration outcomes are shown in Figure 20.

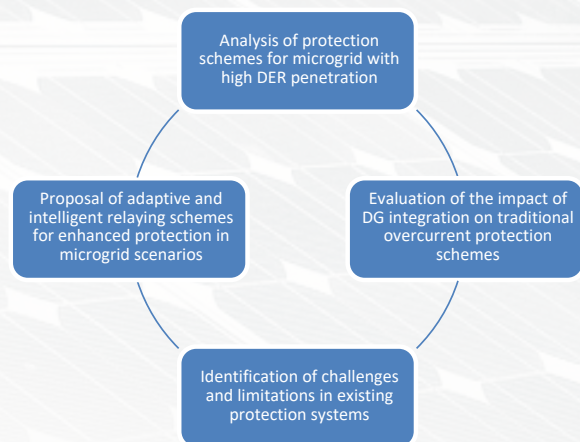

Figure 20: Overview of collaboration outcome on modern grid protection

- The work was carried out on constructing, validating, and simulating a microgrid model for the purpose of investigating protection mechanisms. A set up of a 3-phase microgrid model with DER was developed, which can operate autonomously, or in a grid-connected mode. Simulated faults (all types a broad sample of locations) on the microgrid model. Digital relay and communication models were applied to verify the ability of various relaying schemes to deal with different fault locations, system states, and grid topologies. Evaluation of technology choices, cost implications, and reliability of protective solutions were also examined by the team. Researchers also studied simple microgrid models to understand the impact of digital protective relaying models and explored different communication models for testing and validation. An example case study model is shown in Figure 21.

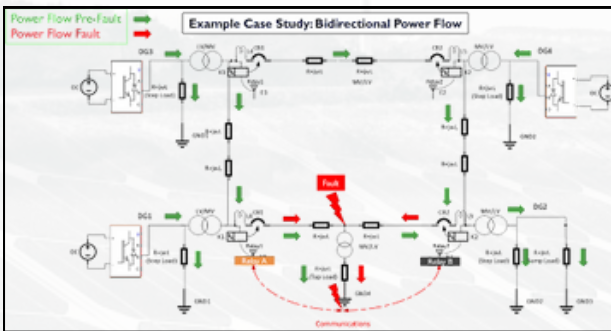

Figure 21: Example case study of protection schemes on DER connected distribution system

- Various islanding detection and protection schemes for AC/ DC/ hybrid microgrids have been developed as part of the research work. A few key highlights are as follows. The magnitude-phase plane of impedance difference (ID) is examined as a parameter of fault detection in AC microgrid. A protection scheme based on the magnitude-phase plane of ID using wide-area positive sequence components of current and voltage signals has also been proposed for AC microgrid. The computation of ID was performed by extracting signals from the phasor measurement units complying with IEEE C37.118 standards, as in Figure 22. Further, a data-mining model-based enhanced differential intelligent relaying scheme was developed for fault detection and classification in AC microgrids. The deep neural network (DNN)-based data-mining models were built using differential current phasors generated by wide variations in fault and operating conditions of microgrid, including different types of faults with change in fault location, fault resistance, DG penetration in grid-connected and islanding modes of operation.

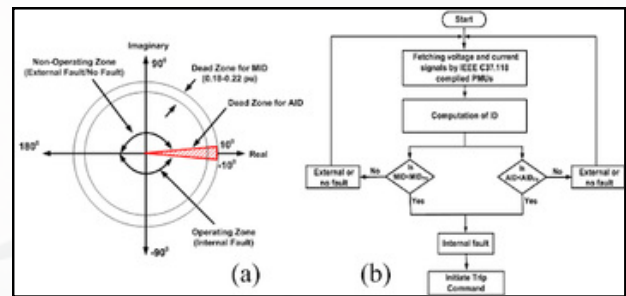

Figure 22: (a) Magnitude phase plane of ID, (b) Flowchart of proposed ID-based protection and fault detection scheme

- A majority of previous islanding detection methods have large non-detection zones, poor power quality, and high implementation cost. Thresholds in most methods are not generic and depend on the system's rating. Hence, a local measurement-based hybrid islanding detection method for DERs has been developed, which utilizes parameters estimated from voltage and current phasors at point of connection of DER using Space Vector Rotation (SVR) and a controlled self-decaying current injection, which is injected only after disturbance detection by SVR parameters to mitigate impact on power quality and have zero non-detection zone.
- Typical DC microgrids have a very high fault current rise due to instantaneous capacitor discharge. Hence, communication-less quick  $\Delta V - \Delta I$  plane-based line faults detection and classification scheme in Low-Voltage (LV) DC microgrid using local parameters has been developed. Simultaneous violations of difference of successive line current and bus voltage, with sum of squared currents and disagreement of instantaneous line current to its average echo, aid the scheme, as in Figure 23, to identify forward and backward faults and categorize pole-to-ground and pole-to-pole faults. Lastly, adaptive protective relay coordination schemes in AC microgrids have also been developed and tested, which are robust to different conditions of the AC microgrid.

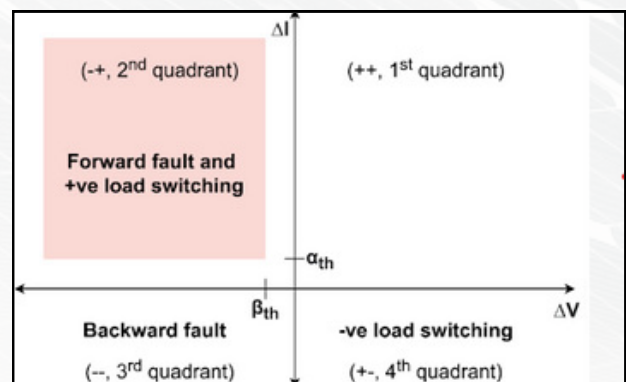

Figure 23: Scheme of proposed  $\Delta V - \Delta I$  plane-based fault detection & classification in LV DC microgrids



## Way forward

- With the ever-growing development in semiconductor technology, the functionalities of above developed converter designs with associated primary and secondary controllers will still be applicable, which will ensure proper coordinated interaction with microgrid energy management system and advanced distribution management system.
- The developed protection and islanding detection schemes are robust to diverse operating conditions and have very little dependency on communication medium. Thus, a major task, which can be taken up, may include assessing the impact of cyber-attacks on the protection and converters' operation and control schemes.
- Understanding relevant standards, regulations and compliance standards ensures appropriate operation and control of microgrids/ active EDNs. The developed methodologies can also aid in improvements of existing standards on microgrids, such as UL 3001 (safety standard for distributed energy and storage systems), UL 1741 (standards for inverters, converters, controllers, etc.), and IEEE P2030.11 and IEEE P2030.12 (standards under development for distributed energy resource management and protective systems for microgrids).
- Large numbers of microgrid technologies (rotating machines, inverter types, topologies, autonomous/grid-connected configurations) create a diverse and challenging operational environment. Operational paradigm needs to embrace distributed and decentralized control and management options moving forward.
- Traditional protection schemes based on overcurrent relays face challenges in microgrids due to the integration of DERs and bidirectional power flow. Adaptive protection schemes show potential in addressing the protection challenges in microgrid. Protection schemes developed for transmission systems can be adapted and applied to microgrid.
- Computational intelligence-based data-mining models, machine learning, and nature-inspired algorithms are gaining momentum for developing protection schemes. These can be effective mechanisms in addition to the conventional relaying methods.

- Advancements in IoT, cybersecurity, and AI can be used for reliability of cloud-based operation, control, and protection schemes in microgrid.

---

## 4.3.3 Cyber Infrastructure and Security

As cyberattacks across the globe are increasing in frequency and sophistication, one of the critical objectives of this project has been to enhance cybersecurity and cyber-resiliency considering the cyber-physical attributes of active distribution networks. The primary outcome of this task has been in the development of a cyber-physical analysis tool, cyber anomaly detection tool, cybersecurity measures and a cyber-resiliency metrics tool for distribution system operations with increased penetration of DERs. It also provides a comprehensive view of how to integrate possible communication technologies based on considering various traditional and disruptive technologies. Offensive and defensive cybersecurity analysis for the field pilots and cyber assets provided possible cyber incidents that could hamper the integrity and availability of data.

### Challenges

With the integration of DERs, the distribution network is transforming into tightly coupled devices and multisource systems driven by bidirectional power flow, advanced sensors, digital automation and data communication. These data and power flows often rely on digital devices and IoT devices that may be connected to the internet. This aids in digital intelligence by allowing the devices to be monitored, share their status, and facilitate communication with other devices. A utility may need to remotely interact with DERs, whereas utilities do not configure most devices and rely on third-party vendors. Many companies do not guarantee secure supply chain management, securing the sensors and digital controllers as well as communication links supporting DERs' services critical to maintaining a reliable, secure and resilient distribution network. Biggest challenge is detection of an attack in real time as attackers will typically try to remain undetected. Also, classifying anomalies as a cyber-attack is a significant challenge given all possible causes of anomalies with similar signatures and data-silos.



## Key Findings

The studies conducted have shown that the field digital devices and sensors supporting DER's services have numerous unpatched cyber-vulnerabilities and access control mechanisms are simplified and minimally secured especially for edge devices. DERs are controlled using an intricate information and communication technology network. Cyber threats associated with these devices and networks need to be scrutinized. The report includes key security incidents that can pose a high efficacy risk. The risks identified are critical vulnerabilities, access control abuse, malware injections, physical tempering of the device, IT to OT access, and software configuration issues.

The feasibility study of communication technologies for the active distribution network provides a comprehensive overview of action-oriented, easy-to-implement options, like LoRa WAN, Narrow Band IoT, GPRS, wi-fi at the consumer end, 5G and optic fiber at the distribution end. The attack surface for the network was analyzed by simulating various attack scenarios on the physical assets and field devices. The simulated attacks, like Denial of Service (DoS), false data injection attack (FDIA), man-in-the-middle (MITM) attack, and GPS spoofing, provide vulnerable points in the microgrid and distribution systems. System performance under various attacks, depending on its stealth, time latency, and nature of resources, were studied.

Change in thinking is required with emphasis not only on cybersecurity and employee trainings, but also cyber-resiliency, which refers to minimizing system impacts due to cyber-attack by isolating compromised devices and recovering remaining systems quickly. Real time monitoring of cyber-resiliency is required for situational awareness and decision support to minimize the impact due to evolving cyber-attack.

A cyber audit of field pilots at various locations identified common vulnerabilities, such as default credentials, clear text password communication, easy authorization, and default open ports, etc. The vulnerabilities were addressed by following the remediation measures for all the pilot projects.

## Solution

The UI-ASSIST project activities lay the conceptual guidelines to build an environment that represents the cyber-physical nature of the active distribution network. Within this ecosystem, various scenarios were explored in which data transmission and information exchange among the DERs, field digital devices, and controllers can be protected and quickly recovered from cybersecurity compromises.

### Some of the mitigation techniques

1. Communication links can be secured with time-varying encryption and time stamps
2. Role-based access control for the critical information infrastructure are listed below in Figure 24:
3. Intrusion detection using cyber-physical data and prevention mechanisms
4. Taking inventory of critical ports and open ports in general
5. Implementation of solid cipher keys
6. Behavioral monitoring to identify anomalies in the network operation
7. Malware entrapment through honeypots or honeynets
8. Cyber audit at the system and device level
9. Implement strict firewall rules (like packet filtering and whitelisting IPs)
10. Secure patch management system
11. Cyber-physical resiliency metrics using data from physical systems and cyber-systems.

Good Practice	Better Practice	Best Practice
User accounts must be classified by authority level or CISO	User accounts are classified based on the functional roles	User accounts must be classified by authority level or CISO as well as the functional role
Assets must be classified in conjunction with user authority level	Assets must be classified in conjunction with function or role based.	Assets must be classified in conjunction with user authority level and function
Operational controls may be accessed by any entity based on user authority	Operational controls may be accessed by any entity based on user authority	Operational controls may be accessed by any entity within a functional group with valid authority

Figure 24: Role-based access control for the critical information infrastructure



## Key Learnings

- a) **Interconnected Vulnerabilities:** The power system's increasing digitalization has led to interconnections between traditionally isolated components, introducing new attack vectors. Understanding how vulnerabilities in one part of the system can propagate to affect others is crucial.
- b) **Human Factor:** Cybersecurity isn't just about technology—it also involves educating and training personnel. Human errors or lack of awareness can be as critical as technical vulnerabilities.
- c) **Adaptive Threat Landscape:** The threat landscape evolves rapidly. Studying current attack trends and tactics helps anticipate future threats and design robust defenses.
- d) **Regulatory and Compliance:** Understanding relevant regulations and compliance standards (e.g., NERC CIP) ensures that security measures align with industry requirements.
- e) **Vulnerabilities and Risk Assessment:** Conducting thorough risk assessments helps identify critical assets, vulnerabilities, and potential impact scenarios for known vulnerabilities.
- f) **Detection and Incident Response:** Any action can be taken only if cyberattack can be detected. Cyber-physical data needs to be processed from streaming, non-streaming and any other information for detection.
- g) **Cyber-resilience driven monitoring, analysis and decision support:** Develop cyber-physical resilience metrics to guide design, planning and operational decision, specially for unknown vulnerabilities.

## Way Forward

- a) **Comprehensive Security Framework:** Develop a holistic security framework that covers prevention, detection, response, and recovery strategies. This framework should encompass technical, procedural, and personnel aspects.
- b) **Asset Inventory and Classification:** Create a detailed inventory of all assets within the power system, classify them based on criticality, and apply appropriate security measures accordingly.
- c) **Continuous Monitoring:** Implement continuous monitoring systems to detect anomalies and unauthorized activities. Advanced analytics and machine learning can aid in identifying patterns indicative of cyber threats.
- d) **Segmentation and Isolation:** Implement network segmentation to isolate critical assets from less critical systems. This containment strategy limits the potential impact of an attack.
- e) **Encryption and Authentication:** Deploy strong encryption for data at rest and in transit. Use multi-factor authentication to enhance access control.
- f) **Regular Penetration Testing:** Conduct regular penetration testing to identify weaknesses in the system. This proactive approach helps address vulnerabilities before they are exploited.
- g) **Employee Training:** Provide comprehensive training for employees at all levels. This ensures that everyone understands their role in maintaining cybersecurity and can recognize potential threats.
- h) **Patch Management:** Establish a robust patch management process to ensure that software and firmware are up to date with the latest security patches.
- i) **Resilience-aware incident response:** Utilize data from physical systems and cyber systems in coordinated manner to design, plan and operate cyber-physical distribution systems
- j) **Scenario-Based Exercises:** Conduct periodic simulated cyber-attack exercises to test the effectiveness of your incident response plan and improve the organization's readiness.



- k) **Regulatory Compliance:** Stay up to date with relevant regulations and compliance requirements, adapting your security measures as needed.
- l) **Continuous Improvement:** Cybersecurity is an ongoing process. Regularly review and update your strategies based on the evolving threat landscape, technological advancements, and organizational changes.
- m) **Resilience-aware incident response:** Utilize data from physical systems and cyber systems in coordinated manner to design, plan and operate cyber-physical distribution systems.

By incorporating these learnings and focusing on this comprehensive way forward, the finding and analysis of UI-ASSIST project can contribute significantly to enhancing the cybersecurity posture of power systems, ensuring the reliability, resilience, and safety of critical energy infrastructure.

### Cyber model of nano-grids

Nano-Grid (n-Grid) may be described as a smart building comprised of rooftop photovoltaic panels, battery energy storage (BESS), electric vehicle charging station and controllable electric load. n-Grid integration with a power system may offer impressive benefits to the system, e.g., enhancing the reliability, resilience and flexibility, or lowering the carbon footprint. A practical example of how to harness the flexibility of n-Grid resources is their participation in the wholesale electricity market (WEM) through aggregation. FERC Order 2222 in the USA enables this opportunity by mandating the WEMs to enable Distributed Energy Resource (DER) aggregator participation in energy and ancillary service products. In our example, the aggregator is envisioned as the mediator between the WEM and n-Grids which can send control signals to n-Grid resources and receive measured power and status of n-Grid resources through the home energy management system (HEMS)—see Figure 26. The aggregator and its n-Grids communicate via the internet of things (IoT).

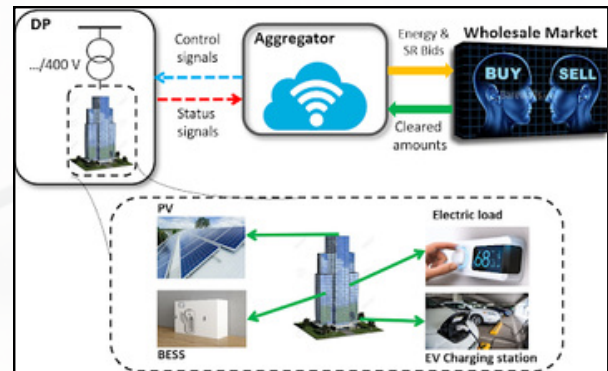

Figure 25: Nanogrid based aggregator framework

### Cyber model of nano-grids

- **Cyber-security and cyber-physical interdependence analysis of the aggregator/n-Grid communication system:** This is of high significance since the aggregator communication with n-Grids via IoT is highly vulnerable to cyber-attacks. Several cyber-attacks were tested and evaluated the vulnerability of the communication system. There were further recommended actions to improve the cyber-security of this setup.
- **Visibility of n-Grid energy resources through blockchain technology:** A blockchain-based framework was proposed to bring about the visibility of DERs to ISOs by secure recording and verification of the monetary, energy and ASP transactions made among the ISO, aggregator and DERs. A use case study was conducted, where the simulation results demonstrate the robustness and efficiency of the framework in making DERs visible and tractable to the ISO.

### Key Outcomes

- Modelled a typical n-Grid/aggregator communication system in Mininet-WiFi software.
- Investigated potential vulnerabilities of n-Grid communication systems to multiple types of cyber-attacks. Performed the following tests: network reconnaissance, man in the middle (MiTM) and denial of service (DoS) using Kali Linux.

- Developed a five-layer model for the cyber-physical interdependence architecture of the n-Grid/aggregator setup.
- Proposed the usage of blockchain technology to detect possible attacks or anomalies.
- Implemented a blockchain-based framework to record energy, ASP and monetary transactions securely, which can be later on used for transaction verification for energy and ASP delivery.
- Developed the Ethereum-based blockchain platform using PoA consensus algorithm. The transactions are generated in Python and Web3.py library enables interface with a private Ethereum blockchain.
- Assessed the applicability and scalability of the framework where high number of transactions can be validated in a short period of time.
- Illustrated that the n-Grids (in our Use Case study) may not be able to deliver the exact amounts of the rewarded ASPs in real-time, which may jeopardize secure operation of the power grid.

### 4.3.4 Advanced Distribution Management System (ADMS)

#### A. Need for ADMS: issues and challenges

With the growth of converter interfaced Distributed Energy Resources (DERs) and the influence of spatio-temporal variations in power generation, driven by consumer preferences and climatic conditions, the complexity in the operation and control of modern Electric Distribution Network (EDN) has increased significantly. The conventional EDN has now transformed into an active EDN with bidirectional flow of power and increased level of network unbalances (both in voltage and current). An Advanced Distribution Management System (ADMS) is a sophisticated software-based automation platform meticulously designed to oversee and optimize modern active EDNs efficiently, securely, and reliably.

#### B. Key R&D Efforts and Developments

Indigenous and inhouse development of the various ADMS functions and the associated platform, which has been integrated with the urban, semi-urban, and rural field pilots in Kanpur for testing the real-time efficacy of the developed ADMS functions on practical pilots, have been one of the key and significant deliverables/achievements of this project.

Figure 26 shows the typical key attributes and features of the developed ADMS platform, which are further discussed next.

Various aspects of ADMS development and implementation have been extensively studied in this project. An encapsulated culmination of a comprehensive exploration into multiple dimensions of ADMS is presented here. The research efforts have delved deeply into pivotal areas, such as load forecasting and profiling, solar and wind forecasting and system inertia monitoring and enhancement, Distribution System State Estimation (DSSE), Volt-VAR Optimization (VVO), Demand Response (DR) with optimal operation of DERs, Network Reconfiguration (NR), accompanied by substantial progress in setting up TSO/ DSO coordination frameworks.

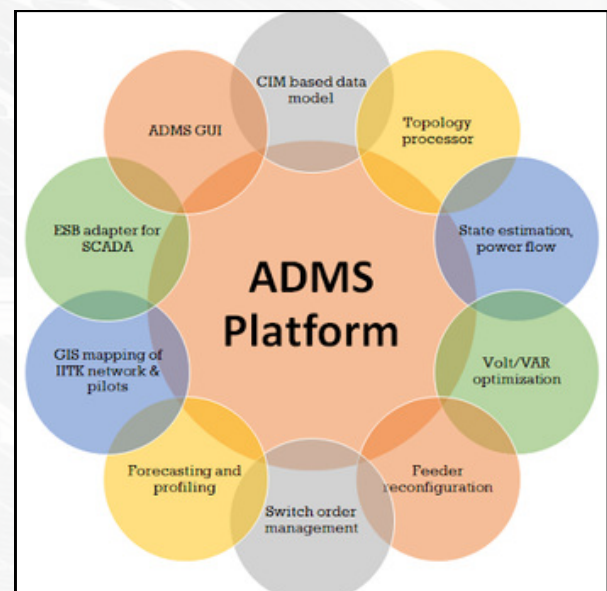

Figure 26: Key functions and features of the developed ADMS platform

#### Summary of R&D Activities

A comprehensive summary of the key findings of the research activities in each of the above pivotal areas is as follows:

## Load forecasting and profiling

Developing robust short-term and long-term load forecasting models is critical in enabling efficient control schemes. These models provide utilities with accurate and actionable predictions, allowing optimal resource allocation and minimizing energy wastage. As part of the key research efforts, several novel time-series and advanced signal processing based techniques have been developed for load forecasting

Additionally, robust and adaptive measurement and machine learning based models for load modelling and profiling have also been developed, as shown in Figure 27. The key end benefits of these approaches are their adaptability and applicability for similar exercises with no need of user specific/ defined inputs or random initialization of variables in the initial steps of the process

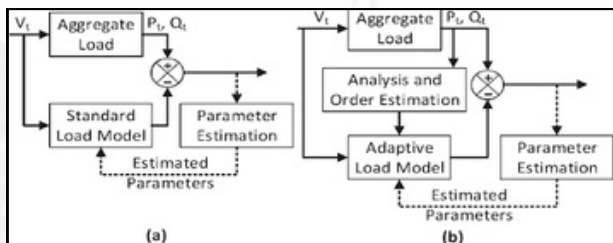

Figure 27: Measurement based (a) traditional, (b) proposed approaches for load modelling

## Solar and Wind Forecasting and Inertia Monitoring

The solar and wind forecasting provide utilities with the tools to effectively anticipate and harness these intermittent resources. As part of the key research efforts, novel time-series and repeated moving window-based wavelet transform based techniques have been developed for short-term as well as long-term forecasting of solar and wind power availability. Figure 28 shows a typical flowchart of the key proposed repeated wavelet transform based approach for forecasting, which have been further used for improved NR of active EDNs. The key benefit of such an approach is that with further decomposition of coefficients, finer and very erratic variations or changes can be easily tracked and hence better forecasted.

Also, it is well known that battery and solar PV based sources are inertia-less, which when integrated in the system, result in increased generation capacity but with no significant change in system inertia. Satisfactory system's inertial response is key to the stable operation of the power network.

Hence, approaches for inertia estimation, using measurements from Phasor Measurement Units (PMUs), and enhancement techniques for improved system stability with the large scale penetration of renewable based DERs are also developed, which have also been tested in real-time via controller hardware in loop simulation.

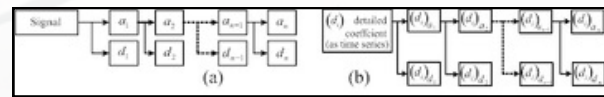

Figure 28: (a) Conventional Wavelet transform, (b) Proposed additional breakup of coefficients in repeated Wavelet transform (a and d coefficients refer to approximation and detailed coefficients)

## DSSE with network topology and parameter estimation

The research works done towards DSSE with EDN's topology and parameter estimation have yielded cutting-edge techniques for real-time monitoring and assessment of distribution networks. Observed findings heightened situational awareness, which is crucial in managing and mitigating disruptions, ultimately bolstering the overall reliability of the grid. As part of our key research efforts, the major focus has been to devise intelligent algorithms that can reliably perform DSSE with limited number of measurements, as most EDNs are not completely observable due to lack of sufficient metering devices. Additionally, network topology and parameter estimation are also critical for proper operation of EDN, as often the status of the elements in EDN are incorrectly updated or recorded at control centres over time due to ageing infrastructure, communication failure, or data packet loss. However, such an estimation is a herculean task due to insufficient Supervisory Control and Data Acquisition (SCADA) based measurements. To this end, micro-PMU and SCADA based data-driven techniques for robust network topology tracking, detection and parameter estimation are devised, which can be used for any practical EDN.

## Network Reconfiguration (NR)

The research works done as part of NR has established that dynamic topology changes offer numerous benefits, including load balancing, reliability enhancement, and reduction in network's power losses. These research works not only focused on operational benefits but also fetch superior computational performance while considering the uncertainties in injections from DERs.

## Volt-VAR Optimization (VVO)

The research works done as part of VVO translates into significantly reduced power losses, improved system reliability, and reduction in the operational costs for utilities. Additionally, integrated VVO, DR, NR, with unbalance minimization has been done for active EDNs, which was not done prior to this work. Integrated optimization, although being computationally intensive, makes sense as the ultimate end objectives of each individual exercise are inter-related, hence, providing cross coupling benefits, and optimal use of available resources, such as capacitor banks, tap changers, voltage regulators, and smart inverters. Alternatively, stage-wise efficient novel indices-based solution schemes have been developed, with one of them being shown in Figure 29.

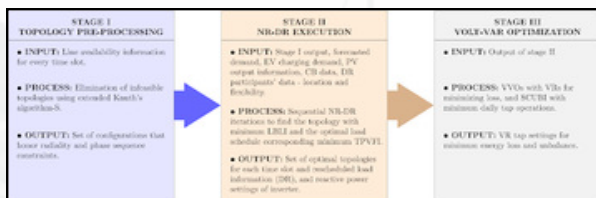

Figure 29: Stage-wise approach for integrated VVO, NR, and DR in active unbalanced EDNs

## Demand Response (DR) with optimal operation of DERs and EVs

The development and validation of advanced DR methodologies empower utilities to engage proactively with customers in dynamic load management, fostering a more responsive and efficient grid. DR strategies reduce peak demand and contribute to grid stability, resiliency, and improved integration of DERs, as shown in Figure 30.

Also, integrating and controlling DERs, especially Electric Vehicles (EVs) and Battery Energy Storage Systems (BESSs), is a critical aspect of modern grid management. The research work has provided clear guidelines for utilities on the optimal operation of DERs, ensuring grid stability, reliability, and sustainability with minimal load and generation curtailments. A few notable R&D efforts are as follows. Novel charging and discharging pricing strategies for optimal scheduling of EVs are developed, as shown in Figure 31, resulting in optimal utilization of charging points and avoiding rebound of peak load over the daily operation in an EDN.

Efforts for optimal planning of fast EV charging stations in a fully coupled transportation network and EDN considering distance-based mapping between nodes for observing the impact of EV charging on EDN is made. Realistic driving range constraints of EVs are also considered while trying to maximize traffic flow based on available forecasts. Several optimization-based routines for optimal day-ahead and real-time scheduling of loads via DR initiatives and resources have been developed. These initiatives clearly bring out the added benefits of DR actions via appropriate financial incentives during day-to-day operation and scheduling of EDNs.

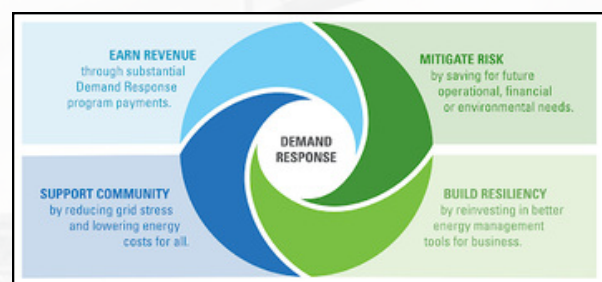

Figure 30: Expected benefits of DR

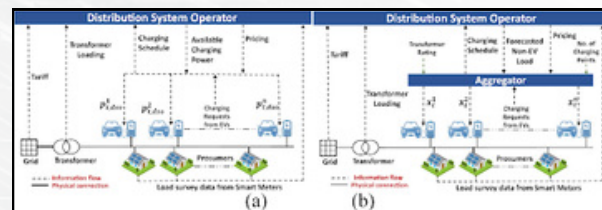

Figure 31: Proposed (a) centralized, and (b) decentralized EV pricing strategies

## TSO/DSO coordination

A DSO-like entity can provide critical function, such as, address the challenges arising in the operation of active EDNs and effectively service the consumers, efficiently utilize flexibility behind the meter in EDN, ensure synergistic interaction with Transmission System Operator (TSO), take optimal network investment decisions, and enable use of data analytics for improved system operation. As part of the key research efforts, the major focus has been to devise optimization engine based routines that can aid the TSO to appropriately visualize as well as extract the flexibility in terms of resource scheduling and adequacy available at the DSO's level, while trying to maintain minimum information exchange with inherent data security. Additionally, the TSO/ DSO coordination problem is often posed as bi-level optimal power flow problem in the optimization routine, which is often not so straightforward to solve directly due to the hierarchy of coordination. A complete fool proof solution of this issue has been proposed.

### C. Development of ADMS Platform at IIT Kanpur

The indigenous inhouse development of ADMS has been jointly done by teams of IIT Kanpur and Synergy Systems and Solutions in India. The developed ADMS, whose features are shown in Figure 32, operates on top of SCADA, which acquires data from remote terminal units and other intelligent electronic devices installed at various locations. Figure 32 shows the schematic of the existing SCADA system at IIT Kanpur campus, along with the developed ADMS at the functional layer.

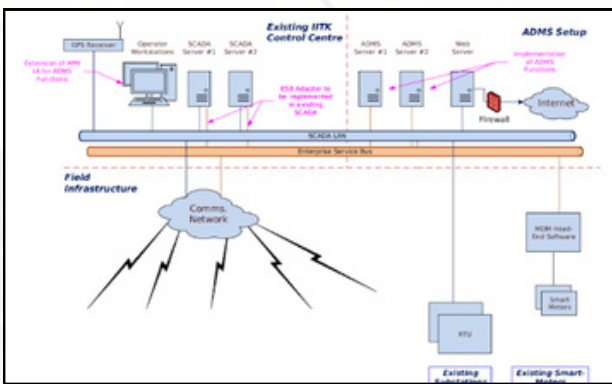

Figure 32: Schematic of existing SCADA and Newly Developed ADMS at IIT Kanpur

The architecture of the developed ADMS is shown in Figure 33. The interface between SCADA and ADMS is developed to acquire real-time data. OPC unified architecture (OPC-UA), as per IEC 62541 standard, supports bidirectional exchange of real-time data via polling and publish-subscribe mechanism. The developed ADMS platform is based on Common Information Model (CIM), which allows for flexibility in terms of modelling of different components of the EDNs in urban, semi-urban, and rural field pilots at Kanpur as per IEC 61970 CIM standard, and ease of future mapping between SCADA/ADMS database and OPC-UA client.

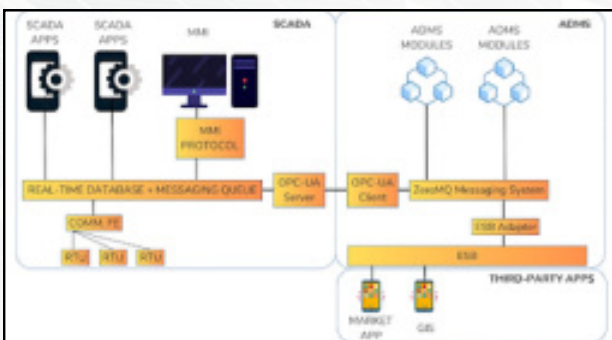

Figure 33: Developed ADMS architecture

Data exchange with external sources or third-party apps is via Enterprise Service Bus (ESB) as shown in Figure 34, which allows for ease of interoperability among different operating standards of different system components and algorithms. The ESB framework provides increased scalability across clients, reduces complexity related to client-specific overhead, and thus improves the overall performance. In the Kanpur field pilots, WSO2 has been deployed to provide the ESB functions between Meter Data Management (MDM) and ADMS, as shown in Figure 34.

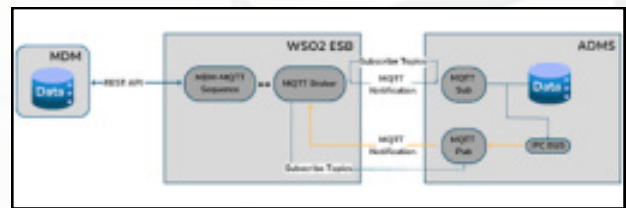

Figure 34: MDM – WSO2 ESB – ADMS in Kanpur field pilots

The developed ADMS allows the addition of new modules, algorithms, or routines (developed as part of R&D efforts) and its interaction with other applications. The plug-n-play concept is to support the addition of new ADMS modules into the system, without the need to modify the logic of existing application. Another added feature of the inhouse developed ADMS platform is that it supports Geographical Information System (GIS) integration, whereby, the electrical assets are grouped using the IEC 61970 CIM elements. The regions are configured with longitude-latitude coordinates in the map, as shown in Figure 35. The geo-spatial rendering in ADMS Human Machine Interface (HMI) indicates each substation or region as a symbol, and all line segments from a region are connected through colored lines. The benefit of GIS is that it provides a geo-spatial mapping/imaging/ status of the assets in the EDN, which can be a useful input in the day-to-day operation and management. Figure 36 shows the CIM based modelling of IIT Kanpur substations in the developed ADMS.

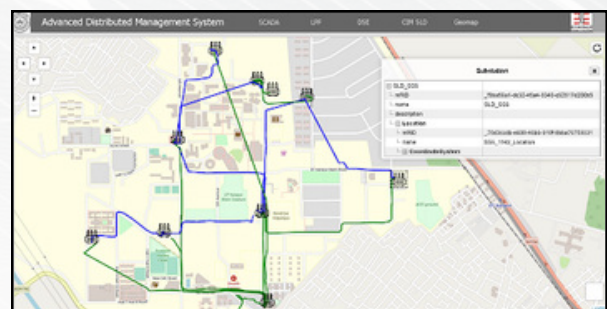

Figure 35: GIS mapping of IIT Kanpur distribution network in the developed ADMS HMI

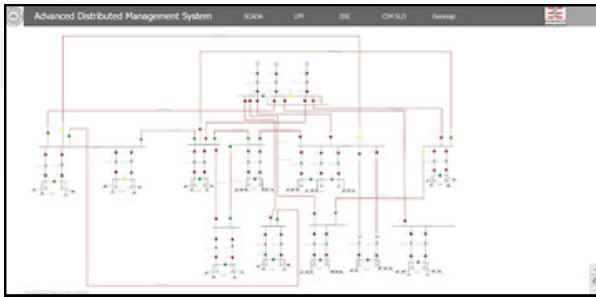

Figure 36: CIM based modelling of IIT Kanpur substations in the developed ADMS

## ADMS in WSU Campus

Distributed Energy Resources (DERs) integrated WSU campus distribution system was modeled in the Advanced Distribution Management System (ADMS). Real-world test cases were run to evaluate various aspects of the distribution system, such as distribution power flow, fault isolation and service restoration, load voltage management, and primary energy resource island formation.

- **Integrated DER Management:** it demonstrates the integration of DERs into the ADMS, allowing for efficient management and utilization of renewable energy sources within the distribution system.
- **Rapid Fault Detection and Restoration:** A fault was created in WSU distribution system in SIM mode and same has been identified using the fault location module within GE ADMS as shown in Figure 37. The ADMS's fault isolation and service restoration capabilities proved effective in quickly identifying faults and isolating affected areas. This functionality minimizes downtime and enhances overall reliability.



Figure 37: WSU distribution network during fault

- **Load and Volt/VAR Management:** It highlights the ADMS ability to keep the nodal voltages inside operational limits, to change the operation point to satisfy power factor requirements at specific locations in the network, or to reduce total demand or losses in the network.

- **Islanding and Energy Resilience:** The primary energy resource island formation showcased the distribution system's capability to operate independently in case of grid disturbances. This feature enhances the system's resilience and minimizes service disruptions.

## Key Takeaway

- ADMS is critical to the future operation of the ever-evolving EDN. A significant amount of R&D effort has gone into the development of the different ADMS functions, that will assist a DSO to operate the EDN economically, efficiently, and reliably with guarantee of better and improved coordination with the upper-level TSO.
- The indigenous inhouse development of the ADMS platform at IIT Kanpur is based on CIM and uses WSO2 for ESB support, which together ensure a unique feature of the developed ADMS, i.e., interoperability and flexibility of easily integrating any ADMS module, external source, or third-party apps in the already developed ADMS platform. Lastly, the ADMS platform allows for testing of the ADMS functions/ modules in the plug-n-play mode (thus obviating the need of changing the logic structure) and has the GIS features, which can provide added visibility to the EDN owner/ DSO.
- ADMS model at WSU was developed and demonstrated in managing a distribution network. The project's real-world test cases underscore the benefits of enhanced efficiency, reliability, and sustainability that the ADMS brings to the distribution system.
- WSU campus distribution system model integrated with DERs was developed in the ADMS to demonstrate a technologically advanced solution.

## 4.3.5 DSO - Market and Regulatory Issues

### Challenges

In the new era of modern power systems, Distribution System Operators (DSOs) face challenges on multiple fronts. The rise in renewable energy integration, such as solar and wind, is driving decentralization, necessitating grid adaptation for intermittent renewables while maintaining grid stability. Simultaneously, the swift electrification of transportation, exemplified by electric vehicles (EVs), places added pressure on distribution grids. DSOs must anticipate the burden due to charging infrastructure requirements and implement appropriate solutions to alleviate grid congestion. These issues can be addressed through smart grid technologies, demand response programs, and energy storage systems.

There is a need for a local-level electricity market to enable prosumers to trade electricity among themselves while creating a competitive environment. Peer-to-peer (P2P) is one of the most popular ways of local-level electricity trading, which facilitates personalized services and enhances prosumer engagement. However, this may create issues in distribution system operation. The existing P2P models do not provide an appropriate revenue-sharing mechanism among the participants. DSOs are responsible for coordinating with Transmission System Operators (TSOs) for the reliable and smooth operation of the distribution network and the local-level electricity market. This includes the appropriate exchange of data between TSOs and DSOs. These issues can be addressed by adopting appropriate regulatory provisions, including data privacy, cybersecurity, designing market frameworks, interoperability, and standardization.

## Key R&D Activities

To address the aforementioned challenges, a comprehensive assessment of the active distribution system landscape has been conducted. The activities undertaken are listed below:

### 1. Distribution Electricity Market (DEM) Framework:

Exploration of various market frameworks and in-depth investigation into strategies, interactions, and mechanisms for local/distributed electricity market optimization.

- Development of a **Game Theoretical Framework**, involving the applications of Game Theory within the conventional retail market structure to optimize power transactions among retailers, distributed generators, and renewable sources, ensuring rational decision-making and maximizing profits among players.
- Formulation of a **Generalized Nash Equilibrium Problem (GNEP)** using game theory to simulate the electricity market as a game. The goal was to enhance bidding strategies, especially in P2P trading, to achieve a GNEP where participants optimize their choices influenced by one another's strategies.
- Developing a **retail market framework for cost-effective EV operational planning** and optimizing the payoffs for different stakeholders, while incorporating game theory and behavioral insights to demonstrate the impact on personal and societal benefits while enhancing resilience and sustainability.

**1. Distribution System Operators (DSOs):**In-depth analysis of regulatory dimensions and global perspectives on active distribution network operation, while emphasizing global disparities in DSO definitions and highlighting the possibilities for DSO emergence and their roles worldwide.

- Examination of **TSO-DSO coordination**, including coordination schemes and market-clearing frameworks.
- Introduction of a **Minimal Data Exchange Framework** to address privacy concerns and standardize information exchange within power systems.

## R&D Approach

The research aims to modernize distribution networks, elevating their role amid the evolving energy landscape while emphasizing economic efficiency and environmental responsibility. The key solutions proposed under this theme are as follows:

### 1. Framework Design for Distribution Electricity Market (DEM) :

Different models have been proposed to facilitate local-level electricity trading, fostering a competitive environment among prosumers. These studies have delved deeply into the complex dynamics of DEM, illuminating the intricate interplay among energy buyers, sellers, and DSOs.

### a) Market Framework: A Game Theoretic Framework

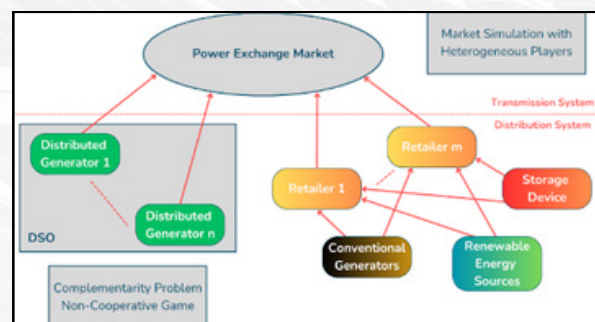

Figure 38: A Game Theoretic Market Framework

- A decision-making model has been formulated that encourages the growth of the P2P market by optimizing players' revenue. Game Theory is employed, assuming rational decision-making among participants and utilizing both non-cooperative (individual competition) and cooperative game theory (group competition).

- Valuable insights were gained from the distributed electricity market, particularly in the context of Peer-to-Peer (P2P) trading, as the application of game theory-based models significantly enhanced the efficiency of these intricate interactions, assuming rational decision-making among strategic participants.
- Furthermore, a comparative assessment of total payoffs at the Nash equilibrium and overall welfare across various scenarios was conducted as part of the research.

## b) Generalized Nash Equilibrium Problem (GNEP)

- Using a Game Theoretic approach, a randomized sample of rivals' bidding coefficients is generated through a joint normal probability distribution function. This information is then utilized by prosumers to refine their decisions for participating in various DEM segments, maximizing their Economic Revenue (ER).
- The approach revolves around a Generalized Nash Equilibrium Problem (GNEP), characterized by mixed strategies where each player's choices depend on others' strategies determined by random actions.
- This problem extensively investigates a P2P market using game theory, employing a two-stage optimization model that emphasizes prosumers' trade-offs within the Distributed Electricity Market (DEM). In the initial stage, non-cooperative game theory and stochastic optimization are applied, with Monte Carlo simulation used to calculate prosumers' optimal bidding strategies.

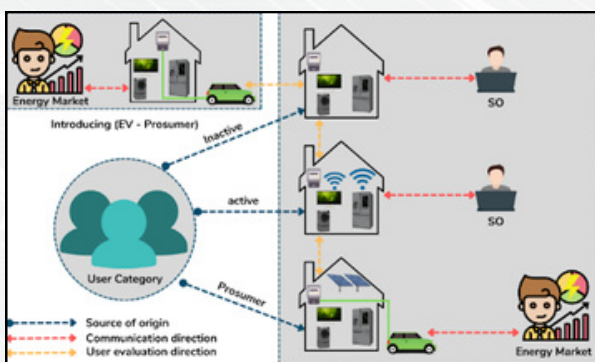

Figure 39: A Framework for prosumer market

The model incorporates linear bidding and cost functions. Prosumers' optimal bidding strategies in the first stage are aligned with the pay-as-clear model. To demonstrate the study's results and relevance, a market scenario featuring four competing prosumers is examined.

## c) A Retail market model using distributed Proximal Atomic Coordination algorithm.

A distribution-level retail electricity market operated by a Distribution System Operator (DSO) was proposed, to permit participation for small-scale DERs in a real-time energy market. The retail market is built upon a distributed Proximal Atomic Coordination algorithm, which solves the optimal power flow using the convex nonlinear Branch Flow model, rendering spatially and temporally varying distribution-level Locational Marginal Prices. A numerical study of the market structure is carried out via simulations of the IEEE-123 node network using data from ISO-NE and Eversource in Massachusetts, US. The market performance is compared to existing retail practices, including demand response with no-export rules and net metering. Results show the DSO-centric market increases DER utilization, resulting in lower electricity rates for customers, from \$0.114/kWh to \$0.0291/kWh. Further, we discuss the policy implications of such a market, including DER participation models at the wholesale level in light of FERC Order 2222, and the evolving business model of the modern utility which is moving from commoditized markets towards performance-based ratemaking.

## d) Retail Market Framework for Cost-Effective Operational Planning for EVs

- The proposed P2P-based EV adoption model incorporates behavioral attributes to illustrate the impact of EV adoption on personal and societal benefits, defining four energy user categories. User welfare is optimized through V2G/V2H interactions using a mixed-integer nonlinear programming (MINLP) model guided by behavioral insights, thereby enhancing resilience and sustainability.
- A mixed-integer nonlinear programming (MINLP) EV adoption model optimizes the welfare of each energy user type through V2G/V2H interactions within two types of micro-grid (MG) settings: MG-I and MG-II.
- The algorithm illustrates the effects of EV adoption on personal and societal benefits, utilizing energy users' 'knowledge gap' and 'risk averseness.' It categorizes users into four groups to represent varying behavioral perspectives on EV adoption. The analysis encompasses both inactive and active consumers without EVs and includes a comparative assessment of their payoffs in relation to two EV-prosumer categories.



**2. Emergence of Distribution System Operators (DSOs):** The research conducted delves into intricate regulatory dimensions and diverse global viewpoints on the operation of the active distribution network.

### a) DSO Implementation framework

- Different possibilities for the emergence of DSOs and their roles and responsibilities are highlighted by examining the international scenario. The exploration navigates through the complexities of governing electricity distribution regulations, with a particular emphasis on the global disparities in DSO definitions.

### b) TSO-DSO coordination

- The vital need for TSOs and DSOs coordination has been emphasized, which is crucial for harnessing the potential of DERs in electricity markets.
- **Day-ahead Energy Market Framework utilizing TSO-DSO Coordination:** A comprehensive examination of the literature reveals a focus on two key facets of TSO-DSO coordination: proposing potential coordination schemes and devising a market-clearing framework.
- **Minimal Data Exchange Framework:** Information sharing depends on goals, market models, and regulations, with privacy's varying importance across power systems. Research has established a standardized exchange format within this framework.

## Key Learnings

### 1. Learning from Framework Design for Distribution Electricity Market (DEM)

Different models are proposed to enable local-level electricity trading, creating a competitive environment among prosumers.

- The local level electricity market should be implemented in a phase-wise manner by considering the present condition of a power system such as, the penetration of DERs, prosumer participation, etc. The local-level electricity market can be implemented in three stages, as shown in the Figure 40 below.

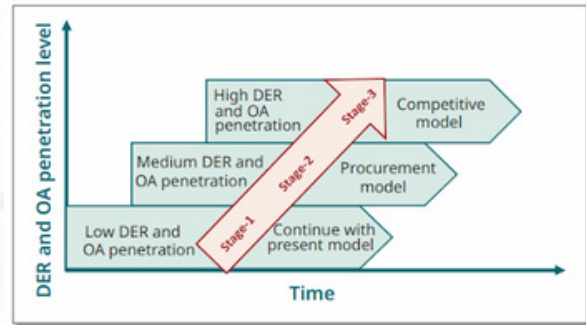

Figure 40: Different Stages of Market Evolution

- The Generalized Nash Equilibrium Problem (GENP) based model suggests that prosumers can make more precise decisions, such as participating in multiple DEM segments. Prosumers' choice of participating in multiple segments enables them to maximize their expected returns more effectively.
- The P2P-based EV adoption model outcomes affirm that enhancing energy users' awareness and risk tolerance regarding EV adoption empowers them to function as grid-independent entities during peak hours. The transformative potential of EV adoption, guided by strategic behavioural insights, helps in shaping a more resilient and sustainable energy landscape.

### 2. Learning from the Emergence of Distribution System Operators (DSOs)

- The various approaches for DSO creation and operation in India have been explored, including restructuring akin to the UK's National Grid model (Option A), rapid transition using existing state units (Option B), transformation of private DISCOMs into DSOs (Option C), and establishing a non-profit DSO (Option D).
- The nature of transmission system is quite different as compared to the distribution system, thus operational and regulatory philosophy of the transmission system cannot be directly adopted to a distribution system. Thus, there is a need for a new distribution operator to address the concerns of the distribution system.
- The distribution system operator can be formed in the following four ways.

- Option A: National Grid model
- Option B: Rapid transition using existing state units.
- Option C: Transformation of private DISCOMs into DSOs
- Option D: Establishing a non-profit DSO.
- The existing four pillars of wholesale electricity market design cannot be directly adopted for local level electricity market design, due to different role and responsibilities of DSO as compared to TSOs.
- The proposed four pillars of the local level electricity market design are listed below and as shown in Figure 41 below.
- Scheduling and Dispatch,
- Flexibility (Imbalance management and ancillary services, Congestion management),
- Settlement, and
- TSO-DSO coordination.

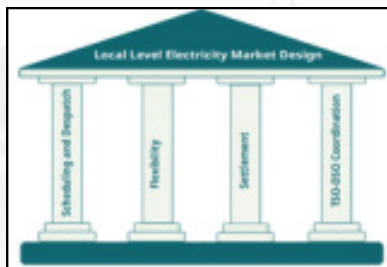

Figure 41: Four pillars of DSO formation

## Way Forward

The potential area of further research includes:

### 1. Distribution Electricity Market (DEM)

- The issue of Real-Time Energy and Flexibility Dispatch by DSO under TSO-DSO Hierarchical Market Structure need to be addressed.
- With the introduction of DSOs, the Gate Closure becomes a critical aspect and becomes more important with the TSO-DSO coordination. Gate Closure time for local energy market, local flexibility market, TSO-DSO coordination, wholesale energy market, and wholesale flexibility market should be synchronously designed.

### 2. Distribution System Operators (DSOs)

- The issue of Real-Time Energy and Flexibility Dispatch by DSO under TSO-DSO Hierarchical Market Structure need to be addressed.
- With the introduction of DSOs, the Gate Closure becomes a critical aspect and becomes more important with the TSO-DSO coordination. Gate Closure time for local energy market, local flexibility market, TSO-DSO coordination, wholesale energy market, and wholesale flexibility market should be synchronously designed.

## 4.3.6 Social Impact Analysis and Policy Recommendation

Adoption of any new technology depends not only on the technical advantages it offers but also its social acceptance & benefits. In addition, it requires proper policy and regulations in place to enable larger deployment in the field. In view of this, social impact analysis of the field pilots implemented under the UI-ASSIST project is established through pre as well as post installation surveys. Certain policy recommendations are arrived based on the outcomes of R&D & deployment activities as well as critical review of existing regulations and policies in India and US relevant to the DER & Storage integrated smart distribution systems. Some of the key findings and recommendations are summarized below.

### 4.3.6.1 Social Impact Analysis

#### A) Social Impact analysis of India rural field pilot

#### Challenges

Analyzing the social impact of mini-grid deployment presents a complex and multifaceted challenge. Understanding and quantifying the effects of providing clean and reliable electricity to remote and underserved communities is crucial for informed decision-making and policy formulation. However, this task involves assessing numerous factors, including changes in livelihoods, education, and overall quality of life. Often in resource-constrained environments, it can be challenging to gather accurate data and conduct comprehensive surveys. Estimating the impact of clean energy access in rural pilot projects and understanding household adoption across various settings is complex. Given the limited purchasing power of rural households, scaling up mini-grids while ensuring financial sustainability is challenging. Finally, overcoming regulatory hurdles may take time, as frameworks often restrict beneficial mini-grid activities. These challenges underscore the need for strategic solutions and adaptability in bringing reliable electricity to underserved communities through mini-grid projects.

## Solution

The study's design for impact analysis, compiles a variety of data on socio-economic aspects of the target as well as the control villages, through a series of structured questions. A survey of the identified villages and the sample of the households were taken to evaluate the baseline socio-economic indicators before the implementation of the project. Based on the analysis of the energy consumption and socio-economic indicators in the control village an expected demand pattern for the identified target village was forecasted. This helped us assess the sizing of the plant and also chalk out the strategies for its future growth including its operational strategies.

## Key Findings

1. The results indicate that both villages have witnessed a growing demand for electricity since the introduction of the grid and renewable mini-grid. The Figure 42 illustrates the typical daily load demand patterns for both summer and winter.
2. It has been noticed that initially household electricity usage was primarily for essential needs like lighting, fans, and in some cases, refrigerators. However, over time, households have increasingly adopted electric water motors, electric chaff cutters, and other appliances.
3. The results underscore a significant increase in the percentage of households engaged in farming on their own land. In Bargadiyapurwa, this Figure 43 has risen from 53.8% in 2018 to 89.1% in 2023, while in Chabba Niwada, it has increased from 56.5% in 2018 to 75.7% in 2023. Conversely, the percentage of agricultural laborers working on others' farms and non-agricultural laborers has declined in both villages. This shift can largely be attributed to the improved availability of water for irrigation, resulting from the installation of solar-powered pumps.
4. The results indicate a reduction in overall illiteracy rates from 17.1% in 2018 to 11.3% in 2023 in Bargadiyapurwa and from 19.4% in 2018 to 13.3% in 2023 in Chabba Niwada. Additionally, the percentage of the population pursuing a bachelor's degree has increased from 2.9% in 2018 to 14.7% in Bargadiyapurwa and from 9.4% in 2018 to 18.5% in 2023 in Chabba Niwada. According to observations on the ground, this increase can be attributed to improved financial resources and a greater awareness of the value of education, encouraging more students, including girls, to continue their studies.

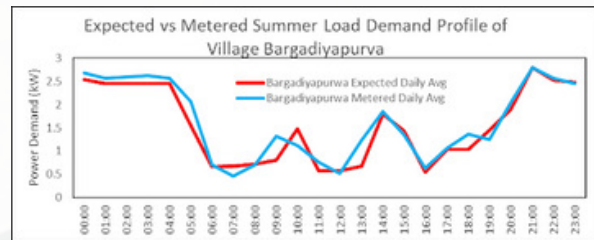

Figure 42: Expected vs Metered Load Demand Profile in Rural Pilot

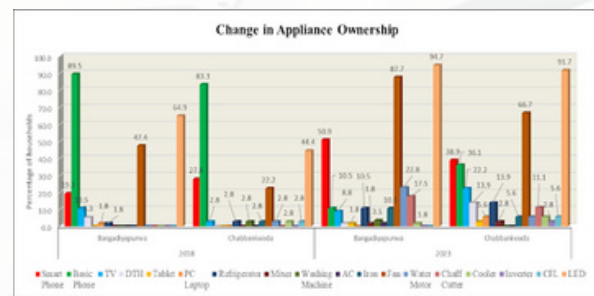

Figure 43: Change in Appliance Ownership

5. There has been a notable shift in cooking preferences over the last five years, marked by a conscious effort to minimize the use of traditional and often less eco-friendly fuels like wood and kerosene. Instead, there has been a significant increase in the use of LPG for primary cooking purposes; the rise in LPG usage from 14.5% in 2018 to 73.9% in 2023 highlights this change.
6. The environmentally harmful forms of lighting, such as kerosene wick lamps, diesel lamps, and petromax lamps, which used to contribute to indoor pollution, have become obsolete with the advent of electricity. This shift has led to the widespread adoption of LED lighting, which has surged from 11.59% in 2018 to a full 100% by 2023.
7. The findings indicate a substantial decrease in the amount of CO<sub>2</sub> emissions due to changes in cooking and lighting preferences. This reduction is primarily attributed to a decrease in emissions resulting from the combustion of wood and husk, which decreased from 43.9 kg of CO<sub>2</sub> emissions in 2018 to 11.0 kg of CO<sub>2</sub> emissions in 2023. Likewise, the shift in lighting preferences also played a role in reducing emissions from petromax, which went down from 6.3 kg of CO<sub>2</sub> emissions in 2018 to zero emissions in 2023.



## Key Learnings

1. Comprehensive assessment of local energy resources, demand patterns, and load requirements is essential for effective system design, emphasizing capacity utilization.
  2. Actively engaging local stakeholders through awareness campaigns, addressing concerns, and highlighting minigrid benefits is crucial for success.
  3. Innovative financial models like pay-as-you-go systems and microfinancing enhance affordability and ensure financial viability.
  4. Collaboration with local regulatory bodies is necessary for compliance with regulations, while advocating for supportive policies can be advantageous.
  5. Involving the community from the project's outset fosters ownership and trust.
  6. Tailoring the minigrid system design to match the community's unique energy needs, resource availability, and economic conditions is vital.
  7. Prioritizing system reliability through proper maintenance and monitoring is non-negotiable, given the minigrid's primary role as an electricity source.
  8. Offering additional services like agricultural processing, water pumping, and charging stations can maximize the impact on community development.
  9. Regularly assessing minigrid performance, both technically and socially, enables timely issue identification and resolution.
  10. Providing training to local technicians for independent minigrid management empowers the community.
2. **Stakeholder Engagement and Advocacy:** Engage with a wide range of stakeholders, including government agencies, NGOs, investors, local communities, and consumers. Foster strong relationships and advocate for the benefits of minigrid projects, emphasizing their potential to drive social and economic development.
  3. **Community Capacity Building:** Prioritize community capacity building by offering training programs and workshops that empower local residents to maximize the benefits of minigrid electricity. This could include skills development, entrepreneurship training, and education on sustainable energy practices.
  4. **Inclusive Business Models:** Explore and promote inclusive business models that allow local entrepreneurs and community members to participate in the operation and maintenance of minigrids, creating economic opportunities and strengthening local ownership.
  5. **Policy Advocacy and Reform:** Advocate for supportive policies and regulatory frameworks that facilitate the scaling up of minigrid projects. Address regulatory barriers and work towards regulatory reforms that encourage investment and expansion.

## B) Sociological Research on Customer perception of DER adaptation in US

### State of the art, needs, and gaps

- The aim was to assess the impact of solar and battery storage technologies on California households, focusing in particular, on nonfinancial factors that explain interest in or having rooftop PV and household level battery storage. Current research on adoption of solar identifies a number of individual characteristics (e.g., sociodemographic characteristics, costs, attitudes, etc.) as well as institutional factors (e.g., incentive programs) that are associated with adoption. In addition, there is substantial evidence that as the number of social installations in a neighborhood increases, the likelihood that a household will adopt increases, though the mechanisms accounting for this association are less clear. There is also evidence that household trust in solar providers matters, but little understanding of the role of utility companies. Finally, there is evidence that households that adopt solar increase their electricity use – existing research explains this pattern with financial and psychological factors.

## Way Forward

1. **Comprehensive Cost-Benefit Analysis:** An in-depth cost-benefit analysis for the pilot implementation should be conducted focusing on its long-term sustainability. Evaluate not only economic aspects but also the broader social and environmental impacts to provide a holistic understanding.



- These gaps were addressed by examining how households' relationships with their utility companies influence their interest in and possession of rooftop PV and battery storage. In addition, we assess possible mechanisms that may explain the effect of penetration rates on household adoption, as well as normative mechanisms that may underlie the rebound effect.
- To accomplish these aims, US team conducted semi-structured interviews with households in the San Diego and Sacramento areas (N=61) and surveys with representative samples of solar adopters and nonadopters (N=3402) in California counties for which solar adoption data were available online.

US partner used interview and survey data collected from California homeowners to assess nonmonetary factors associated with interest in rooftop PV and battery storage. We find evidence that customers who distrust their utility company have higher levels of interest and that normative mechanisms play a role.

## Key Outcomes

- Frequency of important others who have solar is associated with normative expectations about others' attitudes towards solar as well as perceptions that solar is beneficial, and in turn, interest in installing rooftop PV.
  - Frequency of important others who have solar is associated with normative expectations about others' attitudes toward battery storage and in turn interest in adopting battery storage.
  - The number of neighbors with solar is not associated with interest in solar but is associated with interest in battery storage.
  - People disapprove of high levels of electricity use, but that pattern is weakened for households that produce solar energy (as compared to those that purchase electricity from their utility company).
  - Customer distrust in their utility company is associated with higher interest in rooftop PV and in battery storage.
  - Customer distrust in their utility company reflects customers' beliefs that utility companies put their interests ahead of their customers.
- PSPS notifications are associated with perceptions that the utility company is not competent and does not care about customers. Notifications have an indirect effect on interest in self-sufficiency and in solar operating through perceptions of intent, and an indirect effect on battery storage operating through perceptions of both competence and intent.

## Major policy implications from the social survey in US

1. Institutional trust refers to people's belief that the institution cares about their interests and that it is competent. California respondents expressed low levels of trust in their utility companies. This distrust was associated with their interest in self-sufficiency, solar panels, and battery storage. Distrust in utility companies reflected our participants' sense that utility companies did not care about them, were monopolies that did not bear the costs of their mistakes (and were bailed out by the state utility commission at the expense of consumers) and that utility companies encouraged customer behaviors (like installing solar) and then changed the rules (e.g., payoffs) after the fact. PG&E PSPS notifications increased customers' distrust. Given distrust, households that install solar and battery storage may have little interest in contributing to grid needs. And high levels of distrust (as prices of solar and battery decline) may drive people away from the grid altogether.
2. Industry and government actors seeking to engage household-level DER into the grid should consider how their actions affect consumer trust, as well as ways to increase trust. Trust includes not just competence (e.g., reliability and good customer service) but also pro-customer intent.
3. Education regarding the risks of changes (new technologies, policies, etc.) may have little impact on consumers if their concerns are driven by distrust rather than risk.
4. Consistent policy is likely important for maintaining trust; shifting rules and rate structures undermine trust.
5. When consumer trust is low, PSPS notifications may further decrease trust (because they suggest lack of concern for customers as well as lack of competence).
6. Increased accountability of utility companies for their mistakes might increase consumer trust.

7. California respondents expressed little confidence in their understanding of household battery storage. Not surprisingly, people with solar panels had more accurate understanding of how they worked, and low-income respondents reported knowing less.
8. General ignorance about battery storage suggests substantial room for education regarding financial and environmental benefits.
9. Both Democratic and Republican respondents expressed high levels of concern about the environment (though Republicans reported substantially lower levels of concern about climate change than Democrats). Our data suggest positive but inconsistent associations between environmental commitments and interest in solar/battery.
10. Framing benefits of solar/battery around the environment may have broader appeal than framing them in terms of climate change.

### 4.3.6.2 Policy Recommendations

The primary objective of the UI-ASSIST project was to identify the critical issues and challenges which will come to fore with the transformation of the distribution system in the coming years with increasing uptake of DERs. Solar roof top, battery energy storage, micro grids with locally available generation resources, electric vehicles, etc., were expected to be increasingly deployed at the distribution level. The electricity distribution system which was hitherto passive with unidirectional power towards the loads is set to transition to active system with bidirectional power flow. The country specific policies, rules and regulations and international/national standards have also been evolving. A brief account of key policies, regulations and standards as given herein after.

#### Mini-/Micro-grid

A review of the evolution of electricity distribution system in India in the context of the project brings out that the decentralized generation formed a part of the micro-grids which were established to provide electricity supply to far flung/unelectrified areas. Post enactment of Electricity Act 2003, the National Electricity Policy, 2005 inter-alia aimed at deploying decentralized distributed generation wherever it was neither cost-effective nor optimal to provide grid connectivity.

The Rural Electrification Policy 2006 contemplated taking up off-grid solutions based on stand-alone systems for providing supply of electricity to every household. The policy further suggested adoption of isolated lighting technologies like solar photovoltaic, where neither standalone systems nor grid connectivity is feasible.

The schemes formulated by Government of India (GoI) from time to time such as Rajiv Gandhi Grameen Vidyutikaran Yojana (RGGVY) in 2005 aimed to create an infrastructure for rural and household electrification, the Jawaharlal Nehru National Solar Mission (JNNSM) was introduced in 2010, to establish India as a global leader in solar energy which also include off-grid opportunity through decentralized mini-/micro-grids in remote and far-flung area to ensure people with no access to electricity. This led to the formulation of Deen Dayal Upadhyaya Gram Jyoti Yojana (DDUGJY) which carried forward the objectives of RGGVY and aimed towards completion of micro-grid and off-grid electrification. The Model Smart Grid Regulations, 2015 by Forum of Regulators also focused on integrating clean energy into micro-grids.

There are majorly three national level policies in India in regard to mini-/micro-grids, namely tariff policy, national policy on RE based mini-/micro-grids and National Energy Policy. The Tariff Policy, 2016 of the Ministry of Power spelt out the need for suitable regulatory mechanisms to protect mini-grid investments and establish tariff-based mechanisms. MNRE draft mini-grid policy of 2016 provided the target to promote the deployment of at least 10,000 MW of RE based mini-micro-grids in the next 5 years and the draft energy policy brought in 2017 discusses on the deployment of mini-/micro-grids as a multi-point solution for renewable energy access. This also encouraged the States to bring out their own policies and programmes. Six states, namely Uttar Pradesh, Assam, Madhya Pradesh, Odisha, Jammu & Kashmir and Bihar (Draft) framed regulations. However, the capacity ceiling in respect of these grids in various states was however different.

The Figure 44 depicts timeline of policies/regulations related to mini/micro grid in India.

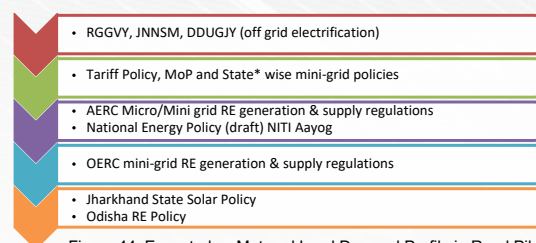

Figure 44: Expected vs Metered Load Demand Profile in Rural Pilot

## 2. Energy Storage

The need for energy storage in the Indian power system was recognized by the CERC in 2017. In view of increasing penetration of VRE in the Indian electricity grid and the need for assessing the readiness of Indian power system to meet the anticipated demand profile, studies carried out brought that the energy storage to be an essential requirement. As per CEA optimal generation capacity mix report for 2029-30 report published in 2020 estimates energy storage requirement of 27 GW/108 GWh. After the assessment, estimation were for the power system in India in aggregate terms. The focus of the Government of India on the decentralized distribution generation systems in the National Electricity Policy brought out by CEA, brings out the requirement of various forms of storage technologies and the storage capacity requirement for the year 2026-2027.

In 2019 government approved National Mission on Transformative Mobility and Battery Storage that lays down the strategy and roadmap which will enable India to leverage upon its size and scale to develop a competitive domestic manufacturing ecosystem for electric mobility and as well as cells/battery. In addition, the cabinet approved a Phased Manufacturing Programme that will assist in the development of large, export-oriented integrated mega facilities in India to produce batteries and cells. The recent guidelines for Procurement and Utilization of BESS as part of Generation, Transmission and Distribution assets, along with Ancillary Services provide flexibility services for the grid by facilitating the purchase of BESS for renewable energy (RE) projects, enabling the procurement of BESS to optimize the utilization of distribution networks, and to provide standardization & uniformity in processes and a risk-sharing framework between various stakeholders.

The Energy Storage Obligations (ESO) is one of the significant stipulation for the development of BESS in India, the notification issued by the Ministry of Power in 2022 specifies the percentage increase each year starting with 1% for the year 2023-24 to 4% in the year 2029-30. In 2022 Government of India introduced the Battery Waste Management Rules with the aim to ensure the responsible handling and management of discarded batteries. They are based on the concept of Extended Producer Responsibility (EPR), which means that battery manufacturers, including importers, are accountable for collecting, recycling/refurbishing, and using reclaimed materials from waste batteries in the production of new ones. India is also introducing/adopting several standards which will facilitate proper operation of BESS in the country. Bureau of Indian Standards (BIS) has formed committees to develop Indian standards in several areas related to secondary cells and batteries (ETD-11), Grid Integration of renewables (ETD-46), Electric Vehicles and charging infrastructure (ETD-51) and electrical energy storage systems (ETD 52).

[https://cercind.gov.in/2017/draft\\_reg/SP.pdf](https://cercind.gov.in/2017/draft_reg/SP.pdf)

[https://powermin.gov.in/sites/default/files/Renewable\\_Purchase\\_Obligation\\_and\\_Energy\\_Storage\\_Obligation\\_Trajectory\\_till\\_2029\\_30.pdf](https://powermin.gov.in/sites/default/files/Renewable_Purchase_Obligation_and_Energy_Storage_Obligation_Trajectory_till_2029_30.pdf)

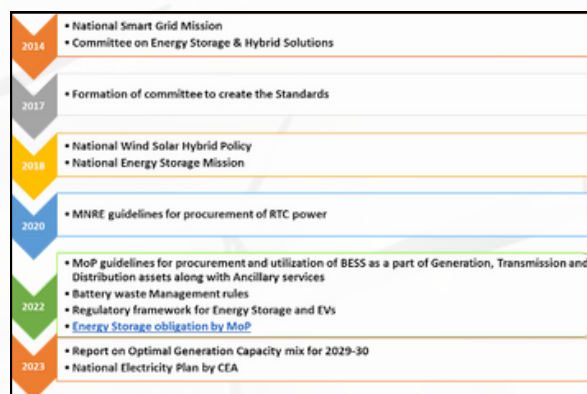

Figure 45: Policies/regulations related to Energy storage in India

The Figure 45 depicts timeline of policies/regulations related to Energy storage in India.

## Cyber Security

With the advancement in technology, most of the existing systems are modernized to increase the reliability of power supply, Cyber security has become an essential part of an active distribution system. Utilities are moving towards automation such as integration of SCADA, embedding Information system (IT) with Operational system (OT) and starting bi-directional communication system help in increasing the reliability of electrical systems as it can be monitored and controlled remotely. This increase in automation or interconnection of communication systems to electrical grid, potential risk of cyber-attack has risen. Cyber-attack in power system may carry malicious intent that aims to compromise or damage grid operations which may lead to mal operation of equipment. These cyber threats may attack the control system of the electrical network for initial access and then move towards other systems with the foothold of compromised environment. Central Electricity Regulatory Commission (CERC) “communication system for inter-state transmission of electricity” regulation in 2017 specifies roles and responsibilities of Central Electricity Authority (CEA) on cyber security. Indian Electricity Grid Code made a regulation which lays down rules, guidelines, and standards in order to plan, develop, maintain and operate the power system in the most reliable and secure manner. In 2021, Central Electricity Authority (CEA) released the Guidelines for Cyber Security in Power System to be adhered to by all power sector utilities so as to create cyber secure eco system. The guideline lays down essential actions for cyber security preparedness across all power sector utilities in order to increase the level cyber security in the sector. The Figure 46 depicts timeline of policies/regulations related to Cyber Security in India.

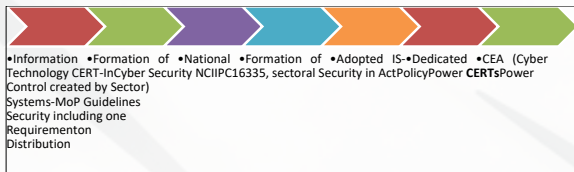

Figure 46: Policies/regulations related to Cyber Security in India

## Distribution System Operators

DERs play a pivotal role in decarbonization as well as in achieving adequacy, reliability and quality of supply even in remote areas. DERs include rooftop Solar PV units, small wind, Battery Energy Storage Systems (BESS), Electric Vehicles (EVs) etc. In the long term, DERs have the inherent potential to help achieve sustainable development goals and reduce environmental impacts. The availability of behind-the-meter data and fair network and market access is vital in making network reinforcement-related decisions. There is a need to study customer behavior and consumption trends proactively. Handling these activities by a neutral entity could boost the consumer’s confidence and attract much-needed investment in the distribution sector. It could bring the necessary transformation and innovation swiftly.

The DSO could serve the purpose and make such data available to different entities transparently for business or investment purposes keeping privacy of consumer data in mind. A dedicated and proactive entity like DSO could also handle cyber security- related issues with the required degree of focus. It can also ensure complete visualization of the distribution network to manage local generation and load effectively.

Utilities and regulators are exploring the feasibility of introducing and implementing the DSO function to ensure optimal utilization of DERs and aiding new business models to emerge. Many electricity markets, such as those in the UK, Australia, USA, Japan, and various European countries, are advancing towards embracing the DSO functions.

## Recommendations

The recommendations have been developed based on secondary research, stakeholder consultations and expert’s roundtable interaction from central/state government officials, private sector and domain experts where several experts roundtable were conducted throughout the project to better understand the challenges and possible recommendations, through consortia partners comprises of industry,

academia and research institute who shared their learning from research & development done through simulation, lab and benchmark systems , learning from pilot implementations in rural, semi-urban and urban locations were also used which showed challenges faced at ground level in terms of technical, commercial and operational front and secondary research.

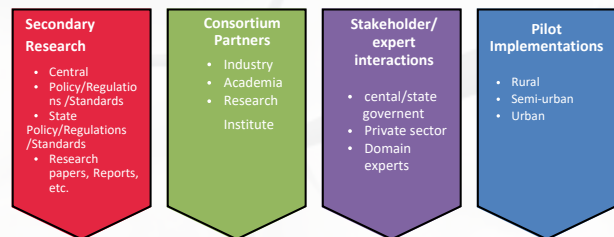

Figure 47: Inputs taken for policy recommendations.

## 1. Mini/Micro Grid

The micro-/mini-grids which were hitherto primarily aimed at providing access of electricity to remote areas where the electricity supply was either not available till then or it was not cost effective to provide electricity supply to such areas, are likely to find a new role/applications by providing ancillary services. The following are some of the recommendations that will increase the penetration of micro-grid in the network.

- Sub-MW sized mini/micro-grids for a cluster of villages for deriving economies of scale
- Sharing of the distribution lines by DISCOMs with Mini/Micro Grid Developers (MGDs) to lower the cost of electricity delivered to the consumers.
- Bank loans under “infrastructure development” instead of “commercial development”
- PPP model: CAPEX funded by government and OPEX recovered from beneficiaries/ consumers.
- Fixing of ceiling tariff by SERC for all mini/micro-grids in the state instead of fixing tariffs for individual mini/micro-grids.



- Promotion of use of locally available renewable sources.
- The penetration of EVs will increase the loading on secondary transformers whose life may be affected negatively. The relevant transformer standard such as IEEE Std. C57.91-2011 on transformer hot spot temperature calculations may have to be updated to account for loading from EV charging

### Mini-/Micro-grid Operation and Protection

- Switching between grid-connected and an islanded mode, transition is required to be completed within milliseconds
  - Some inverters must convert from a voltage waveform following to a voltage forming energy supplier
  - All transitions must be compatible with protection for both the interconnected distribution grid and the local requirements of the micro-grid
- The standard for the interconnection of inverter-based resources to the grid is IEEE Std 1547-2018; The IEEE Std P2030.7-2017 to P2030.11 are the approved standards exclusively addressing micro-grids out of a portfolio of several standards under the same name (P2030)
- P2030.12 is an evolving IEEE Standards Guide exclusively devoted to Micro-grid Protection.
- Relaying mechanisms for micro-grids and active distribution networks depend on communication. Problems may arise a) when communication fails (fallback, or backup); b) when communication malfunctions (cybersecurity); c) when communication is hacked (data privacy)
- Current versions of standards do address communications; we are identifying situations that may need to be addressed (i.e. the above example of transition between grid-connected operation and islanded emergency supply mode).

### 2. Energy Storage

A policy and regulatory framework for energy storage is essential for the development of energy storage systems in India. The following are some areas for improvements that could help to accelerate the adoption of energy storage systems in Indian grids. Introducing these measures will aid in establishing a strong regulatory structure that expedites India's shift towards a cleaner energy future.

- Roadmap for deployment of BESS for different applications in distribution system and their prioritization
- Stacking of applications for better utilization of BESS and its cost effectiveness
- Exploring second use of EV batteries for grid scale applications and pilot demonstrations to build stakeholders confidence
- Viability gap funding (VGF) till the time they become viable
- A regulatory framework/mechanism to formulate the tariff design for the operation of the energy storage system duly considering CAPEX and OPEX of the system
- Ramping up capacities of existing testing facilities and add new ones to certify energy storage systems as per the revised BIS safety standards.
- Capacity building for DISCOMs officials, system integrator for BESS operation, handling and maintenance

### 3. Cyber Security

Cyber security policies, strategies, and programmes are among the security management instruments that must be thoroughly assessed in light of the cyber threats and risks that exist in the power distribution system. Given the wide spectrum of cyber risks that power control systems face, it is critical to identify and assess these threats in order to provide the best possible protection for these systems. Some of the recommendations mentioned below can assist in establishing optimal power system security. Key recommendations for cyber security are:

- Every utility to follow NIST cyber security framework for improving critical infrastructure-
  - Identification of cyber assets and users
  - Detection of ongoing threats & Response strategy
  - Protection from cyber-attacks & Recovery mechanism
- Regular audit of IT and OT systems through CERT-In enroll cyber security auditors periodically - say every 6 months.
- Detailed vulnerability/ threat/ risk analysis of the systems deployed/to be deployed by DISCOMs/DSOs
- Formulation of policies for disposal of Critical Digital Assets (CDA)



- Supply chain risk management: Stringent regulations for multi-level checks on equipment imported for power distribution sector
- SCADA connectivity with RTU must have suitable hardware/ software firewall.
- RTU to communicate with whitelisted SCADA servers only. Requests from unauthorized systems/IP to be rejected and logged by the RTU.

#### 4. Distribution System Operations

The DSOs are recommended to ensure safe and secure operation of emerging distribution system in coordination with SLDCs in focused manner. Certain new functions are proposed to be performed by DSO include Forecasting (DER), Market Facilitation, Resource Adequacy and Ancillary/Flexibility Services. Based on the review of existing national and international learning and studies, recommendations on technical, regulatory, institutional manpower & skill requirement aspects, and implementation plan are presented hereinafter:

##### • Technical Recommendations

- Flexible ADMS architecture based on open standards such as IEC Common Information Model (CIM) (IEC 61968) for seamless modifications in future; data analytics with predictive capabilities.
- Data exchange via Enterprise service bus (ESB) (middleware) for standardized data exchange among applications and devices
- Use of Open source languages for ease of further developments and cost effectiveness
- ICT architecture enabling seamless and cost-effective integration of new technologies
- Headend & meter data management system with flexible service-oriented architecture, configurable for data exchange over CIM/ESB

##### • Regulatory recommendation

- Will need modifications in additions to existing codes/regulations to address new functions and to perform existing functions in requisite manner.
- Regulations for granular behind the meter forecasting in rise of large scale Integration of DERs and digitalization in the distribution network

- DSO-TSO Coordination: Defining, data/information requirement and periodicity of data exchange.
- Market facilitation: Developing enabling framework for local energy market, community energy market, etc.
- Resource Adequacy for operation planning in consultation with distribution licensee periodically.
- Integrated network planning for next 5 years
- Scheduling and Despatch: review of regulations considering the roles & responsibility of various entities
- Coordination between wholesale and retail markets, and between market agents (TSO, DSO, aggregators)
- Both energy and ancillary markets, including retail-specific grid services like voltage/reactive power management
- Data collection and communication equipment/protocols for settlement purposes
- Institutional recommendations
- Phased implementation of institutional arrangements depending on the model adopted by a state
- Human resources: typical functional groups their responsibilities and skill requirement suggested
- Clustering of states based on smart meters, DERs, and public charging stations suggested.

#### 5. Distributed Energy Resources

DER can have many financial, economic, environmental, and social benefits for utilities, power markets, and end users. It offers the potential for better service reliability and power quality. They can increase energy security and improve the balance of trade for countries that rely on imported fuels for power generation. Policy and regulatory framework for development of DER is essential for development of active distribution system. The following are some of the recommendations suggested for planning and operation of DERs.



## Planning Metrics for DERs to achieve Resource Adequacy

- Existing reliability indices are sufficient metrics for DSO's system planning activities. However, currently we do not have reliability standards or acceptable targets for the metrics for distribution systems. Uniform reliability standards like the NERC standards for the bulk power system should be developed for the distribution systems that could be enforced at the regional level.
- One area of concern is the lack of standardized data collection. DSO's do not have sufficient information about the behind the meter DERs installed by the customers owing to reasons of privacy.
- A standardized protocol where essential system information is accessible to the DSO without violating customer privacy concerns will be needed.
- Changing utility business model: Increasing DER penetration results in lower net profits for utilities from a commoditized market. Without new business models, utilities may not be able to operate and maintain the network, reducing overall reliability.
- Retail market participation should be encouraged.

## Operational Metrics for DERs to maintain Reliability (and Resiliency)

- Information exchange with DERs or aggregator is required for DER visibility at both DSO and TSO level
- Communication is needed between DER, ADMSs and EMS at SCADA rates
- Integrated Cyber-Security metrics need to consider both transmission and distribution levels
- Resilience metric requires data for combining different system characteristics
- Resilience metric will have to consider DERs and customer loads with some kind of priority
- Value for resilience service provided by DERs is much needed
- DERs have to interconnect in secure manner with continuous data monitoring and logging
- New regulations needed for DERs to participate in either the wholesale market (e.g. FERC 2222) or some new retail market structure

## Social and Environmental Impact

- New standards needed for resilience definition and metric with coordination for existing ones (e.g. NERC CIP for DER integration and ongoing IEEE SA P2856)

---

## 4.4 Deployments: Field and Lab Pilots

### 4.4.1 Field Pilots

- Under the UI-ASSIST project smart distribution system concept, developed through R&D efforts and validated in the lab, are demonstrated in ten field pilots. Out of these following five field demonstration pilots are set up in India.
  - One rural field pilot in a village of Kanpur jointly set up by IIT Kanpur, local utility DVNNL and an NGO Shramik Bharti Foundation.
  - One semi-urban pilot set up by IIT Kanpur inside its campus in Kanpur
  - One semi-urban pilot set up by NETRA in their Greater NOIDA office complex
  - An urban pilot consisting of three sub-pilots by TERI along with BRPL, a local utility in New Delhi.
  - One Urban pilot set up by IIT Kanpur in its campus
- Five more pilots are set up in US as given below.
  - One urban pilot at Spokane, WA by WSU along with local utility AVISTA.
  - One semi-urban pilot by WSU inside their campus in Pullman, WA.
  - One urban ADMS-MEMS pilot by WSU with GE.
  - One semi-urban pilot by TAMU inside their campus on nano-grid
  - One rural pilot by WSU on the local utility NRECA system.

### 4.4.1.1 Field demonstration pilots in India

A brief description of the five pilots in India are given below.

#### A. Rural Field Demonstration Pilot in Kanpur, India

Under the rural field pilot in Kanpur, two microgrids are being set up, one in each of the two village hamlets in Kanpur district, Uttar Pradesh (UP) state, India, which were not electrified. These microgrids are interconnected via converter interfaced link for the bidirectional power flow between hamlets. These have been planned based on results from a socio-economic survey and local resource assessment, and consist of adequately sized Solar PV system, Lithium-Ion Batteries Energy Storage System (BESS), Hybrid biomass system, and microgrid Energy Management System ( $\mu$ EMS). In addition, six solar pumps are installed to meet the irrigation requirements. A unique community-based management model for sustained operation and maintenance of the microgrids has been conceived, and a number of agro-processing cottage industries are being set up to boost local employment

The rural field pilot in India has been implemented in two village hamlets (Chhabba Niwada and Bargadiya Purwa) of Harnoo panchayat village at Kanpur, Uttar Pradesh state, India, which were initially unelectrified (as shown in Figure 48). A large number of consultation meetings with villagers and social surveys were conducted (Figure 49) to assess their electricity requirements, income status, local resource availability, agricultural and other social needs. This pilot has an interconnected microgrid system that houses solar PV plant, battery storage, and biomass plant, in the two hamlets to ensure 24x7 power supply. The local utility partner UPPCL/DVVNL has now brought grid supply to these hamlets to be connected to the microgrids system planned. This pilot also has solar irrigation pumps (Figure 48), installed at various locations to meet irrigation requirements. The key distinguished features of the rural microgrid pilot are as follows.



Figure 48: (a) Unelectrified Village, (b) Consultation meeting & social survey, (c) Solar Pumps for irrigation needs

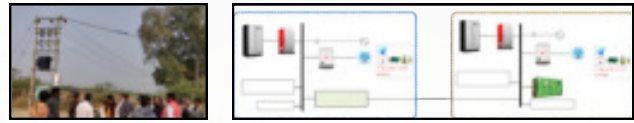

Figure 49: (a) Grid supply subsequently brought by Utility partner DVVNL, (b) Microgrid Components & Layout in village hamlet Chhabba Niwada & Bargadiya Purwa

#### Innovative Technological Solutions

- The type and sizes of the renewable sources and storage system has been decided based on the extensive social survey results, keeping in mind abundance of solar irradiance available, large number of cattle in one of the hamlets, and poor reliability of the local utility supply subsequently brought in these hamlets (Figure 49).
- A solar PV system of 70 kWp and 100 kWh Li-Ion based battery storage system, integrated with the utility grid, is installed in Chhabba Niwada hamlet (Figure 49). Further, a solar PV system of 30 kWp, a bio-mass system of 30 kW, and 100 kWh Li-Ion based battery storage system, integrated with the utility grid, is installed in Bargadiya Purwa hamlet (Figure 49). The 100 kWh Li-ion battery energy storage systems are provided with battery management systems (BMS) in each hamlet.
- Both the hamlets are interconnected with a 25 kW AC-DC-AC converter and power cable for bi-directional power exchange. The two hamlets are also provided with streetlights and smart metering for local billing.
- The microgrid setup of both the hamlets is integrated with a microgrid controller (MGC), which is configured with control logics for optimally operating different energy sources, storage and loads of both the hamlets. It can operate in grid connected as well as isolated modes. The MGC will also control the bi-directional power flow between hamlets.
- The rural microgrid setup is being integrated with the Advanced Distribution Management System (ADMS), developed and installed at IIT Kanpur, for better monitoring and control.
- Total six solar irrigation pumps, installed at various locations in the two hamlets, are also remotely monitored from the control room at Chhabba Niwada hamlet as well control centre at IIT Kanpur.
- The rural microgrid setup is equipped with 3 levels of controls, viz. primary control at the converters, secondary controls by the MGC and associated protection devices, and the tertiary control provided by the ADMS system in the control centre at IIT Kanpur, about 45 km away from the village.
- Smart meter and MGC data are being exchanged through use of appropriate secure communication link and utilizing cloud platform for certain applications.

## Social and Environmental Impact

- The rural pilot is utilizing green and renewable energy sources like solar PV and biomass, which are mostly carbon neutral, addressing the environmental concerns.
- Different energy sources planned, along with adequately sized and optimally controlled Battery Energy Storage System (BESS), is ensuring continuous and sustained supply to the villagers.
- The post-installation survey has revealed that the availability of continuous supply will help children in their education and will create new opportunities for villagers.
- Installation of solar pumps for irrigation water requirement has increased the agriculture yield in the two hamlets.
- A separate processing plant building is set up to house few agro-based cottage industries, which will enhance local employment/revenue generation and thereby social upliftment of the villagers.
- The biomass plant not only produces electricity but also provides high quality manure to increase agriculture production. Utilization of cattle waste in Bargadiyapurwa hamlet is helping in improving cleanliness of the villages.

## Size/Scalability

- This microgrid pilot at present caters to approx. 170 household consumers (about 700 villagers' population) and has provision to be extended to more number of consumers.
- The microgrid setup can be easily replicated and scaled up in other villages in India.
- More cottage industries can be set up with the availability of the reliable electricity supply helping in enhanced revenue generation and local employment.

## Business/Sustainability Model

A unique management model of the rural pilot setup has been put in place. A local society has been formed predominantly involving village panchayat (local administrative body) and a non-governmental organization (NGO). It will manage the rural microgrids after the handover of the project, which will also collect the electricity charges from villagers. The utility has agreed to provide single point connection to the two hamlets and provide electricity to the society with net metering facility. Necessary technical training is being provided to the manpower being utilized from the villages for its maintenance and operation.

## B. Semi-Urban Field Demonstration Pilot in IIT Kanpur, India

One semi-urban field pilot demonstration plant is implemented inside IIT Kanpur campus. This includes Solar PV, Battery Energy Storage System (BESS) with Hybrid inverter, EV charging stations. For the implementation of this field pilot 30 single storey houses are selected in residential lane 32 and 33 for the rooftop solar PV installation with the centralized battery energy storage system (BESS) and Hybrid inverter at the outgoing feeder in the substation. All 30 houses are installed with single phase smart meter which are communicating to the cloud MDM and monitored at Smart grid control centre. Semi-urban microgrid monitoring and control is done using the microgrid control (MGC). The Schematic of Semi-urban field pilot and EV charging station layout are illustrated in Figure 50, Figure 51 & Figure 52 respectively. The key distinguished features of the semi-urban microgrid pilot are as follows.

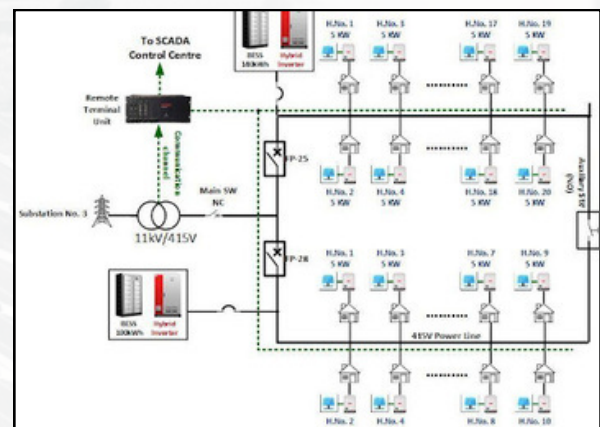

Figure 50: Schematic of Semi-urban field pilot

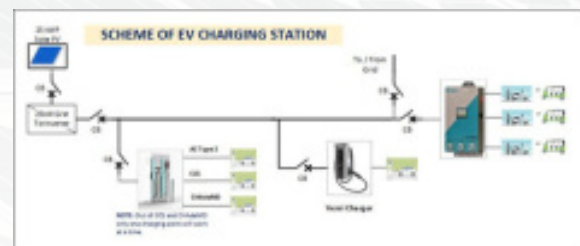

Figure 51: (a) EV Charging station at Type2 community, (b) Schematic of EV Charging Station

## Innovative Technological Solutions

- The specifications of the renewable sources and storage system were decided based on the load pattern, availability of solar irradiance and rooftop area. The objective was to reduce the dependence on grid supply and improve the load supply reliability through storage and support the grid through excess solar energy.
- Total 14 Monocrystalline silicon PERC type 380 W Solar PV modules are connected with 5 kW of grid tie inverter in every house. 12 houses in Lane-32 and 18 houses in Lane-33 were selected for installation based on the survey done for shadow analysis.
- The BESS capacity is 50kW, 100kWh with Hybrid inverter in Lane-32 and 70kW, 140kWh with Hybrid Inverter in Lane 33. Installed hybrid inverters are used as grid forming inverters which provides reference to grid tie inverters in absence of main grid supply.
- Three types of EV chargers are also installed in this field pilot implementation. These are 50kW compact power charger having 1 CCS, 1 CHAdeMO and 1 AC 22kW socket, 4.2kW 1 phase Versicharge for four wheelers with V2G functionality, and Bharat charger having three ports each of 3.3kW which can be used for charging three 2 wheelers or three 3 wheelers in parallel. Two similar setup of all three types of EV chargers are installed which are supported by 25kW Solar PV plant.
- Microgrid Controller (MGC) is used for data acquisition, monitoring and controlling of the microgrid. The operating philosophy logics were developed to incorporate control logic in the MGC installed in the smart grid control centre.
- Single phase bidirectional communicable meter has been installed in each house which are communicating to Data Concentrator Unit (DCU) over RF communication and DCU is sending collected data to cloud Meter Data Management System (MDMS). DCU has ethernet as well as GPRS connectivity option for communicating data to cloud-based MDM portal and ethernet is used inside the IIT Kanpur campus.
- The Communication architecture of Semi-urban field and its status screen through HMI are illustrated in Fig. & respectively.

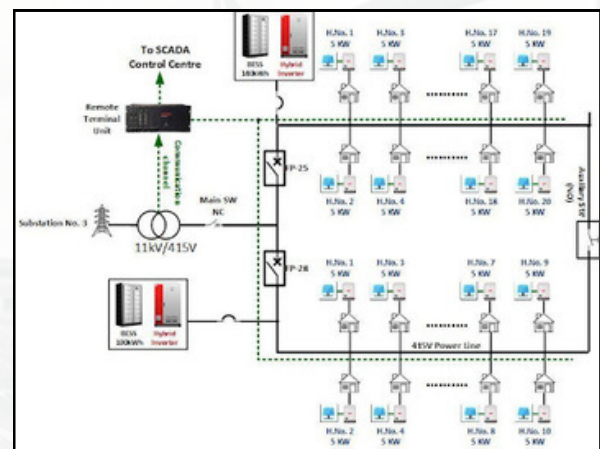
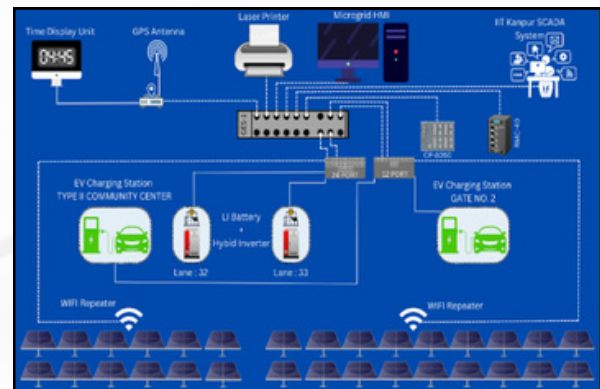

Figure 52: Communication Architecture and HMI interface

## Social and Environmental Impact

- This microgrid pilot is utilizing renewable energy sources like solar PV, which are mostly carbon neutral, addressing the environmental concerns.
- This has sufficiently sized and optimally controlled BESS to ensure uninterrupted power supply to the load and store the excess energy from solar PV.
- High dependence on electric supply in all sections of society has revealed the importance of continuous supply in day-to-day life of users.
- This system has improved the awareness of the users about renewable energy and EV and its benefits like reduction in grid import, uninterrupted supply and reduction in electricity bills.
- The EV Charging facility on campus is available to any EV user that motivates others to shift towards electric transportation.

## Size/Scalability

- This semi-urban microgrid pilot is presently catering to 30 houses in the campus (about 100 campus residents) in two residential area lanes. It can be further extended to many other locations.
- This semi-urban microgrid setup can be certainly replicated and scaled up in many other distributed communities within a control area from electrical system point of view.
- Along with battery, other storage technologies like Hydrogen, Gravity based can be integrated in such microgrid as secondary back up system for critical loads like Hospital and Defense establishments.
- This type of system can enhance local employment/revenue generation and thereby ensure the upliftment of the society.

## Business/Sustainability Model

- This semi-urban microgrid is managed through the Institute works department (IWD). The maintenance of solar PV panels, and technical support to associated components are provided in house. New ACDB panel has been installed inside the substation which has one incomer and three outgoing. Two outgoing breakers are used as grid connection for the Hybrid Inverters installed for lane-32 and lane-33 and one is spare.
- This system has high CAPEX and low OPEX and payback period is much smaller than life of the project. Therefore, it has sustainable business opportunity with hybrid energy storage options.

## C. Semi-Urban Field Demonstration Pilot in Greater Noida, India

Another semi-urban microgrid field pilot is implemented by NTPC Energy Technology Research Alliance (NETRA) in Greater-Noida campus with Solar PV, municipal solid waste (MSW) to energy and BESS. The objective is to improve the reliability and self-sustaining in terms of electricity generation, waste management with a long-term sustainability model. Due to change in originally committed rural pilot site in a Banwasi village of Rihand UP, the execution work of this semi-urban microgrid is not yet completed. It is in advanced stage of completion. The Schematic of Semi-urban field pilot at NETRA campus is illustrated in Fig 56. The key distinguished features of the semi-urban microgrid pilot are as follows.

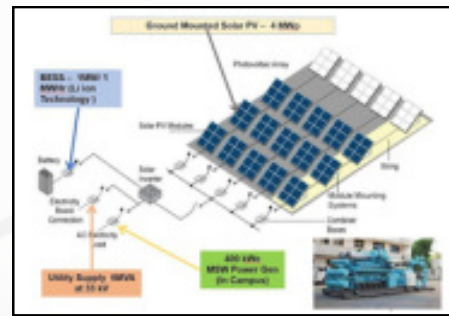

Figure 53: Schematic of NETRA Semi-urban field Pilot

## Innovative Technological Solutions

- In this project, 'Green Campus' has been envisaged as an environmentally conscious premises with zero grid power and with complete green electricity. For Electricity Generation, and for self-reliant electrically, power requirement will be met through in house generation from Solar PV, MSW-RDF based gasification system for generation of electricity and having Battery Energy Storage System, with the existing grid connection will be surrendered in phased manner in couple of months down the line.
- In this project, the real challenge is the design and development of hybrid controller which will interact with different generating sources such as MSW, Solar PV, BESS and DG Set in NETRA campus, along with various loads for electrically balanced off grid system. From the load curve and the PVSyst generation curve it was clear that the 3.2MW/4MWp Solar PV plant is capable of catering load of NETRA campus and charging the energy storage such as BESS(1MW/MWhr) and generation of green hydrogen using 250kW PEM electrolyzer and 25kW HTSE (High Temperature Steam electrolyzer).
- The load profile and monthly solar PV hourly plant power data are analysed with PVSyst to ensure a stable and reliable power supply, enhancing the overall efficiency and resilience of the microgrid system.
- To meet the intended demand of 1 MW, solar PV system of 4 MW DC and 3.2 MW AC is considered. To support any power fluctuation 400 kW MSW will serve as an alternative power source. Excess power generated by the solar PV system will be utilized to charge the battery storage.
- Power backup is required to ensure autonomy, however, achieving complete power supply to match the projected load requirement with a one-day autonomy would necessitate a storage capacity of up to 3.5 MW. This option would not be economically feasible and 1 MW BESS is considered in this system.

## Social and Environmental Impact

- The municipal solid waste (MSW) disposal methods are predominantly via uncontrolled dumping, open-air incinerators, and landfills. The MSW technology will reduce the air and water pollution, land degradation, emissions of methane and hazardous leachate, and climate change.
- It can enhance the awareness about the MSW problems like clogs drains, creating stagnant water for insect breeding and floods during rainy seasons as well as the benefits of technology to convert MSW into electricity.
- Utilization of solar energy as a renewable energy source will help achieving the carbon neutral goals as well as address the environmental concerns.
- Integration of BESS in semi urban microgrid pilot ensure continuous power supply to the load and improve the productivity of their daily life.
- It will help companies improving their ESG score and reinforcing investors faith in the companies business.
- Addressing the larger issue of climate change and adding resilience to power supply against natural disasters such as cyclonic storms and earthquakes that disrupt normal power distribution. Such technologies can help critical places like disaster relief camps, potable water pump systems, Hospitals & mobile/telephone tower/exchanges in mitigating the aftermaths of any natural disaster.

## Size/Scalability

- It is a step towards development of large-scale micro grid as the NETRA campus has already installed AC and DC microgrids through other projects. The objective is to integrate all these microgrids for their campus and make it 'Green Campus' with zero grid power and with complete green electricity.
- The Power capacity of 1 MW for the Battery Energy Storage System (BESS) has been chosen to effectively cater to the load requirement and provide start power to MSW for 4 hrs during non-solar hours. This decision is based on the understanding that the MSW plant can largely meet the power demand during non-solar hours. The BESS capacity of 1 MW will provide additional support to ensure a stable and reliable power supply. During other times the BESS will be used for smoothening the power curve to absorb any fluctuation in generation from MSW, Solar PV or Load. The response time of BESS being fast, it is best suited for smoothening.

- Two primary power sources Solar PV of 4 MWp and MSW of 400kW collectively contribute to the energy supply and stability of the microgrid, ensuring a reliable and sustainable power system.

## Business/Sustainability Model

- The operation of microgrid sources SPV, MSW & BESS will work in sync with grid. The power source priority will be Solar, then MSW, followed by BESS and finally Grid.
- In case of curtailment, a reverse order will be applicable i.e., BESS will be curtailed first and SPV will be the last one to be curtailed in case generating sources are more than the load. Based on the actual load, curtailment/ ramp up of power will be done so that minimum power is drawn from the grid.
- BESS will be used to smoothening the power and will supply power to load only when load > (Solar + MSW) and State of Charge (SoC) of BESS is enough to cater to balance load to ensure the reliability as well as efficient operation of BESS.

## D. Urban Field Demonstration Pilot in IIT Kanpur, India

One urban field pilot by IIT Kanpur covering two residential apartment towers is provided with Solar PV and BESS. In case of power failure and non-availability of Solar PV output, BESS will feed only lift loads and common area lighting loads. This also includes a new Thermal Energy Storage (TES) system of 545 TRHR and reviving 230 TRHR non-functional TES system in Centre for Environmental Science and Engineering building, operating successfully as a part of urban pilot implementation. Microgrid energy management and BESS charge/discharge control is implemented through a microgrid controller (MGC).

## Innovative Technological Solutions

- Monocrystalline Silicon PERC Solar PV modules of 380 watt are installed in array configuration to make 25 kW solar PV plant at rooftop connecting with 87.5kVA of Hybrid inverter in faculty residence multistory apartment block-C and block-D in the IIT Kanpur campus.
- LFP batteries with total capacity of 25kW, 50kWh are installed and integrated with Hybrid inverter at 512V.
- In case of power failure and non-availability of Solar PV output, BESS will feed only common area lighting and lift loads.



- A hybrid inverter is installed in faculty residence apartment block-C and block-D for the implementation of urban microgrid. The rating of Hybrid inverter installed is 87.5kVA/512V in block-C and block-D which has three phase smart PCS.
- The Centre for Environmental Science & Engineering Building, IIT Kanpur having AC load of 150 TR is meet out by 1x75 TR Capacity chilled water air-conditioning plant in combination with the 775 TRHR capacity TESS (Phase Change Material), brine chiller, pumping and heat exchanger.
- The air-conditioning load of this building shall be through the Institute chilled water grid during the charging mode of the TESS and the chiller would operate for charging the 775 TRHR TESS.
- Microgrid Controller (MGC) is used for data acquisition, monitoring and controlling of the microgrid. The operating philosophy logics are controlled by MGC installed at smart grid control center.

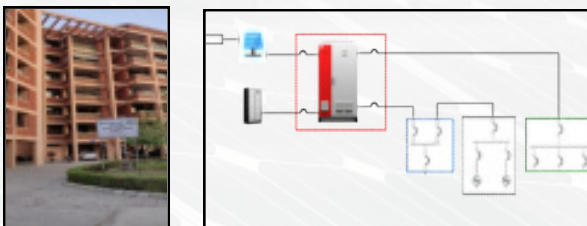

Figure 54: (a) Schematic of Urban field Pilot at IIT Kanpur  
(b) Apartment of Urban field Pilot

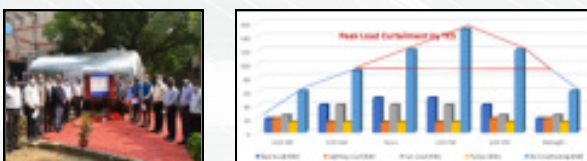

Figure 55: (a) TESS installation in IIT Kanpur campus,  
(b) Peak Load Curtailment by TESS at CESE

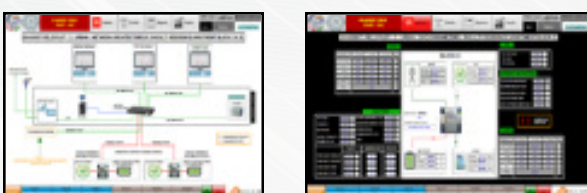

Figure 56: (a) Communication Architecture of Urban Field Pilot,  
(b) HMI screenshot for monitoring

## Social and Environmental Impact

- Carbon emission reduction by 75 tons per annum as Electrical Peak load curtailment by 75 kW
- Reliability of air-conditioning plant operation enhance due to readily available TESS that is charged by running the chiller with Clean energy utilization of solar PV.
- Carbon neutral goals can be achieved by utilization of solar energy as a renewable energy source also to address the environmental concerns.
- BESS integration in urban microgrid ensures reliable power supply to the critical loads.

## Size/Scalability

- R & D opportunity to optimize the TES sizing & for enhancing the efficiency in the field of heat exchanger, compressors and controls.
- This TES design is scalable depending upon the electrical and cooling load requirements of the user.
- This system can be optimally sized considering the tariff structure of the utility to reduce the electricity bill as well as carbon emission.

## Business/Sustainability Model

- This urban microgrid plant is managed through Institute works department. The maintenance of solar PV panels, TES and technical support to associated components are provided in house.
- Changeover panel has been installed in both residential apartment block-C and block-D where grid supply, output of hybrid inverter with battery and DG are connected to switch different sources as per requirement.
- This system is attractive for multi-story residential apartments, commercial office buildings and complexes.
- This system has high CAPEX and low OPEX and payback period is much lesser than life of the project therefore it has sustainable business opportunity with hybrid energy storage options of thermal and electrochemical.

## Integration of IIT Kanpur field pilots with ADMS platform

The objective of ADMS is to provide a shared network model and a common user experience for all roles which are required to monitor, control, and optimize the secure operation of the electrical distribution network. The power network defined through CIM editor is used in real-time by MMI and schematic similar to single line diagram is displayed on which real-time data are displayed for the field pilots.

Different applications which are integrated in the developed ADMS are mentioned below:

1. Topology processor
2. State estimation
3. Power flow
4. Volt/VAR optimization
5. Feeder reconfiguration
6. Switch order management
7. Forecasting and profiling
8. GIS mapping

All the data from the semi-urban and urban field pilots are integrated using Microgrid Controller (MGC) for monitoring using existing communication infrastructure of IIT Kanpur. Data from MGC installed at Smart Grid Control Centre is shared with ADMS platform using IEC 104 protocol. Some of the applications such as Load flow, State Estimation, Volt-VAR, Feeder Reconfiguration have been tested successfully for the urban and semi-urban microgrids integrated with the ADMS platform. Load flow and state estimation for the rural microgrid is also integrated with ADMS platform. The microgrid controller provides data to the SCADA system, which is then telemetered and used by ADMS. Switch control is also implemented on IEC 104 for the field pilots (urban and semi-urban).

Rural field monitoring has been done using Microgrid Controller (MGC) installed in the Chhabba Niwada Village hamlet, which is collecting data of both the village microgrids and the GPRS module has been installed in the Chhabba Niwada village hamlet for establishing the remote connectivity to the ADMS application running at Smart Grid Control Centre at IIT Kanpur. ADMS also facilitates the tertiary control for the rural pilot to adjust the power reference points of microgrid controller and battery energy storage system. Geographic information system (GIS) mapping has been done on all three pilots. A typical screenshot of rural pilot is given below.

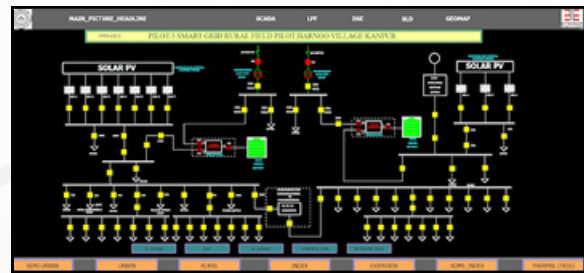

Figure 57: MEMS screen of ADMS application for Rural field Pilot

## E. Integration of IIT Kanpur field pilots with ADMS platform

TERI in association with partner utility, BRPL, have undertaken installation of Battery Energy Storage Systems (BESS) at different locations in the distribution licensee area of BRPL in NCT of Delhi. The urban pilot is divided into following three categories, which were decided after analysing the load profile and use cases that provide benefit to the consumer and the utility:

- CAT-A: Demonstration of grid-scale energy storage systems for a selected distribution/ LT feeder.
- CAT-B: Demonstration of grid-scale BESS for a housing society having rooftop Solar PV power plant installed.
- CAT-C: Demonstration of grid-scale BESS for a selected Research Institution under HT category, having existing Solar Rooftop PV systems.

### Innovative Technological Solutions

#### Category-A: Demonstration of grid-scale energy storage systems for a selected distribution/ LT feeder

The area selected for pilot demonstration is at a DT substation in New Friends Colony – Taimoor Nagar in New Delhi. BESS is connected to the LT (Low Tension) terminal of the DT with a total capacity of 288 kWh. BESS contains 4 racks of 72 kWh each with a prime objective to do the overload management of the DT. The DC output is connected to the 140 kVA Power Conditioning System (PCS) which is a bi-directional conversion system that supply AC power to the grid (DC-AC conversion) during discharging of BESS and receives (AC-DC conversion) during charging.

The Battery racks, HVAC and FFS are placed in a Puff paneled container which is IP54 rated that protects the system from any dust and water inrush. The control and monitoring can be done through remote monitoring via Energy Management Systems (EMS), which is remotely connected to TERI HQ (for monitoring) and BRPL SCADA centre (for monitoring & controlling) through secure channel of SSL VPN based internet connection (this is applicable for all three pilots).

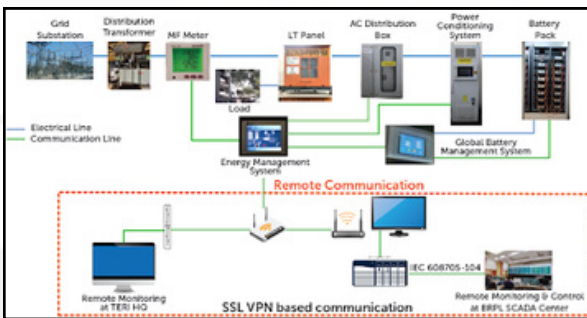

Figure 58: Schematic of Category-A Pilot by TERI/BRPL

## Applications

### Primary application

Overload management of 990 kVA, 11/0.415kV distribution transformer. BESS will discharge when DT loading happens to be more than pre-defined threshold level (80% of DT rating) and charge during DT loading below the pre-defined threshold level.

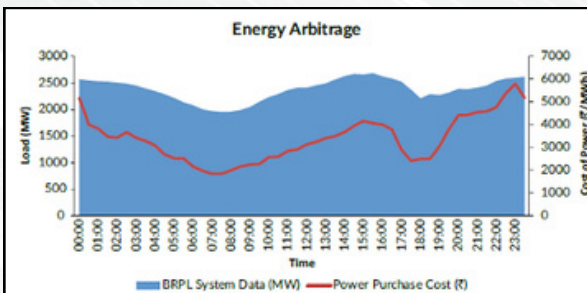

Figure 59: Energy Arbitrage in Category-A Pilot

### Secondary application

Peak power purchase cost saving through energy arbitrage. Charging of BESS during low-tariff periods and discharging it during high-tariff periods (utility perspective).

## Category-B: Demonstration of grid-scale BESS for a housing society having rooftop Solar PV power plant installed

The area selected for pilot demonstration is a residential society in Dwarka Sector 4 – Ispatika Apartments in New Delhi. BESS is connected to the LT (Low Tension) terminal of the DT with a total capacity of 216 kWh. BESS contains 3 racks of 72 kWh each with the objective to reduce the usage of DG set and back-up supply to the common critical loads (lifts, water pumps, streetlights etc.) during power outage. The DC output is connected to 270 kVA Power Conditioning System (PCS) integrated with isolation transformer. The society has a 320 kVA Diesel Generator (DG) which runs on 60 % of its rated loading during power outage. Additionally, the society has a 120 kWp solar rooftop installation that powers the society's critical loads.

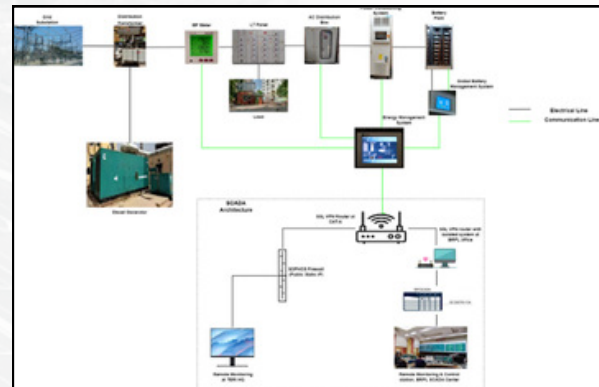

Figure 60: Schematic of Category-B Pilot by TERI/BRPL

## Applications

### Primary application

BESS will provide back-up power to the critical loads during outages to reduce the dependency on diesel generator. During power outage, BESS will provide power (discharge) to meet the critical demand of 240 kW for half an hour; beyond 240 kW EMS will switch to a DG set to supply power also if the power outage persists even after the BESS has been fully discharged.

## Category-C: Demonstration of grid-scale BESS for a selected Research Institution under HT category, having existing Solar Rooftop PV systems

The area selected for pilot demonstration is a research institute TERI School of Advanced Studies (SAS) – Vasant Kunj, New delhi. BESS is connected to the LT (Low Tension) terminal of the DT with a total capacity of 72 kWh. BESS contains 1 rack of 72 kWh with an objective to perform energy arbitrage under Time-of-day (ToD) tariff scheme. The campus has a 48.2 kWp rooftop solar plant and comes under the ToD tariff scheme which is operational for 4 months in a year. The BESS will store energy during off-peak hours when the power is cheaper and demand is low and shall discharge during peak hours when the utility tariff is high. The DC output of the battery is connected to a 56 kVA Power Conditioning System (PCS) which is further connected to a 60 kVA isolation transformer.

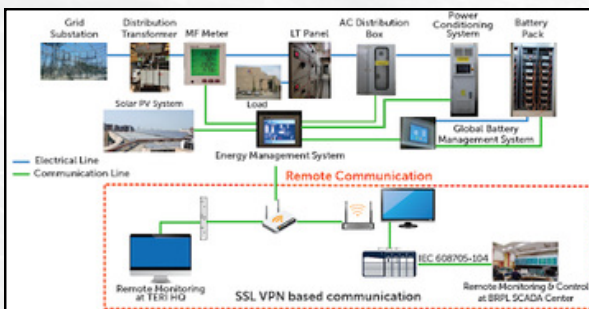

Figure 61: Schematic of Category-C Pilot by TERI/BRPL

## Applications

### Primary application

Energy Arbitrage, time of the day (ToD) tariff applicable during May to Sept months and BESS is charging/discharging at constant C-rate based on the available energy in battery & duration(s) for charge/discharge.

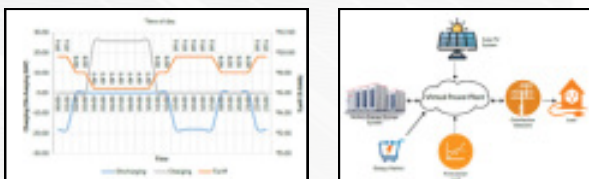

Figure 62: (a) Impact of TOD tariff in Category-C Pilot, (b) VPP concept in Category-C Pilot

### Secondary application

Dispatchable solar generation using BESS through Virtual Power Plant (VPP) concept and optimal utilization of distribution energy resources during peak hours. BESS will discharge based on solar generation (48kWp rooftop SPV plant installed at site) profile and available energy in battery.

### Social and Environmental Impact

- Carbon reduction of 17.3 ton per year for the system installed at CAT-C if the system is charged through installed 48 kWp solar rooftop plant.
- Reduction in diesel consumption for a housing society during power outage which intern will reduce the carbon emission.
- BESS integration in the distribution network will ensure reliable power supply to the critical loads.

### Scalability/Replicability

- This system can be used for distribution transformers (DT) which get overloaded beyond 80%. During peak summer, several DTs in the distribution network get overloaded for some time. BESS can be used to reduce the stress on the DT and augmentation of DT can be restricted.
- BESS can provide backup power to the critical loads of hospitals, tier I or II cities and cold storage facilities, which frequently experience power outages and are supplied by DG sets.
- As one of the applications as Virtual Power Plant (VPP), this concept can be scale up to system level, where all the BESS/DERs are connected virtually at DISCOMs level and are monitored & controlled centrally.

### Business/Sustainability Model

- By using energy arbitrage, utility can save money by charging BESS during off-peak hours and discharge during peak hours. In terms of consumer perspective, time of day tariff (TOD) is applicable for commercial/institutional consumers. With charging/discharging of the BESS, consumer can reduce their electricity bills.
- By charging BESS through solar power, utility will be able to reduce the charging cost of BESS which is generally lower than average power purchase cost (APPC).

## 4.4.1.1 Field demonstration pilots in US

### A. WSU Field Pilot

This field implementation is focusing on self-sustainability and islanded microgrid capability of university campus distribution system with integration of PV and energy storage system and traditional generation sources (gas and diesel). The campus distribution system model was studied in RTDS environment in 2014. It simulated cases and validated the system's capability of integrating PV systems and energy storage in the system. There is a gap between the real-time model and field model where practical issues still exist like communication delays, measurement data acquiring and processing issues, lack of ADMS, etc. This field implement built the real campus distribution system as a model for control schemes of PV and storage system and measurements data stream to Advanced Distribution Management System (ADMS). It provides field experience for campus distribution system modernization.

This pilot project implementation consists of field deployment of 1) Battery storage system, 2) Inverter. Emphasis is placed on the ability of the system to demonstrate several use cases on an actual urban/office building.

### Technical Details of the Pilot

#### Single Line Diagram/Block Diagram

The PCC or point of common coupling for the inverter is the distribution panel where most critical loads of the building are connected. This distribution panel is a part of the remaining distribution system of the same building. This hierarchy and connection philosophy is illustrated in the simplified single line diagram given in Figure 63.

**Further it supports** 1) model update and revalidation, 2) long term objective and economic benefit analysis for PV and energy storage planning, 3) validate control scheme and transition stability between islanded model and grid-connected mode. 4) field implementation of management system considering different test scenarios.

### Social and Environmental Impact

1. Several use cases surrounding batteries of this scale could be conveniently tested within the jurisdiction of US team.
2. It will be possible to run long-term use cases since the system is dedicated for research and not for any commercial use.
3. It is further expected that results from this pilot will help evaluate the feasibility of other small scale battery storage systems across Washington State. In the longer run, this is going to aid the state law makers in deciding where to relocate the adjunct capacity from the retiring coal and natural gas power plants, and if battery storage could be a viable option considering the prevailing area conditions.

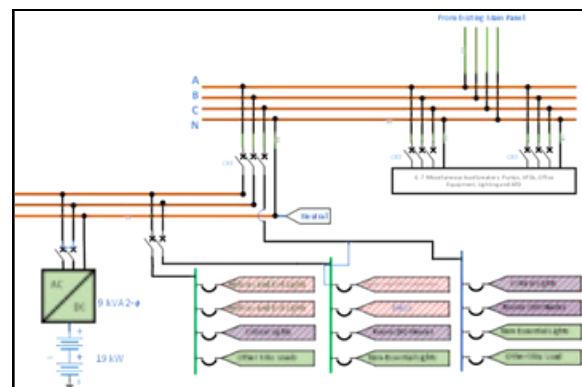

Figure 63: WSU distribution system with BESS near McCluskey Services building

### Innovative Technological Solutions

Field pilot is capable of performing different testcases that demonstrate advance campus buildings functionalities with storage:

1. Peak load reduction of the building.
2. Critical load support during utility outage.
3. Energy arbitrage between local utility and building.
4. Replicating an EV charging station for area wise EV-adoption trend studying.
5. Interfacing with local ADMS of the facility.
6. Volt-Var and reactive Power Support

### Size/Scalability

1. Although considering the scale of the project, a major financial impact from savings incurred from peak shaving and load survivability is not expected, a significant value from the research-based impact of the implementation of the case scenarios is expected.
2. Implementation of bigger large-scale battery of higher rating can provide ancillary services at the town level and participate in energy arbitrage with the local grid operator. It can result in bigger boost for high penetration of solar PVs.

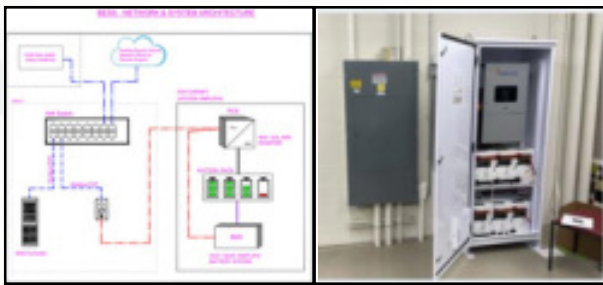

Figure 64: WSU BESS installation site and network interface architecture

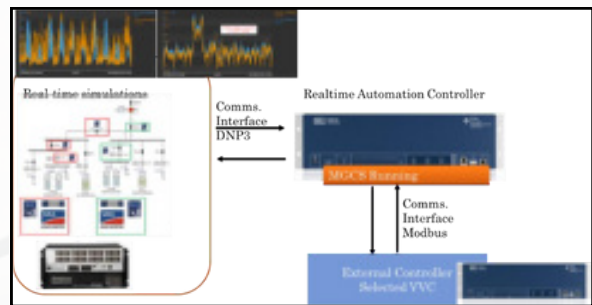

Figure 65: VVC Testing with AVISTA field model using HIL

## Business/Sustainability Model

This model is self-sustainable and serviced under WSU facilities which cater to the daily needs and provide benchmark for further implementation of similar systems across campus. It can also lead to new market transactions through the DER aggregators if adopted in large scale and size.

### B. AVISTA Field Pilot

Field demonstrations are useful to validate the technological solutions on particular system model rather than applying on entire distribution system so that their impact analysis and economic benefits are well known before final implementation on large systems. Most of the available field project demos focused on campus microgrids and fall under semi-urban distribution system. There is growing interest towards urban field demos that fulfil this gap. This pilot includes demonstration of developed technologies (e.g. volt-var control) on field Urban pilot. This lays out the path forward to all the upcoming technology demonstrations that do exist at research stage.

This Urban Pilot 1 field implementation focuses on demonstrating solar system, energy storage, intelligent meters and microgrid technology in university district, Spokane. The unique features of the demonstration area are:

1. Large area. The district covers 770 acres of mixed-use urban land.
2. Diverse loads. The distribution system serves academic and mixed-use buildings, residential neighborhoods, and undeveloped and underdeveloped land.
3. Advanced control and forecasting. The real-time data streams from building management system, solar and storage control system, and intelligent metering system to elaborate optimal and economic power dispatch and outage ride through.

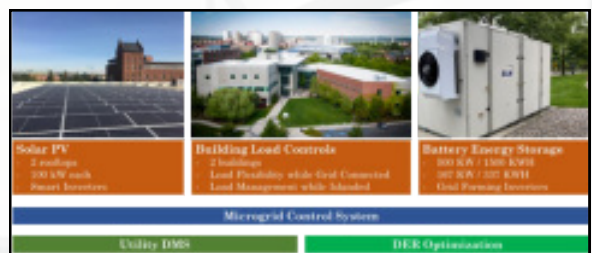

Figure 66: AVISTA Field Site

## Scalability

This field demo will help the electrical power system planners and utility companies to have example case study with real impact assessment and utilization of trending solutions across the globe. It also maps the real system to simulation environment, and studies the impacts from time varying loads, energy storage and solar panels on urban distribution system. This will help different utilities in transforming indigenously developed local volt-var support scheme to field deployable technologies and in providing guidelines and outline critical procedures involved.

## Impacts

The planning strategies, modeling and simulation, system application results of this pilot offer a solution reference for modernization of an existing urban power distribution systems across USA.

## C. US Rural Field Case Study

Over the last decades, the significantly increasing severity and frequency of extreme weather events caused by climate change, resulted into substantial loss on people's lives and critical infrastructure. During past seven years (2016-2022), a total of 122 billion-dollar natural disasters had happened, resulting in more than \$1 trillion in damage and at least a loss of 5000 lives. One of the important drivers of the loss is that in five of the last six years, the U.S. had been severely impacted by Category 4 or 5 hurricanes. Increasing frequency of hurricanes will cause more significant challenges to power system resilience in coastal areas, especially remote or rural island communities that have tenuous connections to a centralized electric grid. A collective effort is focused on the transition of the islands to clean and resilient energy systems. As the energy transition of islands to renewable energies, the role of battery energy storage system (BESS) is not only to increase system operation reliability economy, what's more important is to cope with the higher risk of outage caused by hurricanes or other extreme weather challenges.

To cope with the rising risk of isolation from the main grid during extreme weather events, there is a need to transform weakly connected islanded power systems into flexible microgrids with renewable generation and battery energy storage systems (BESS). Traditionally, the size of energy storage is determined by minimizing investment and operational costs or aiming to alleviate the impacts of intermittent renewable energies. Without considering the expected duration of power outage during isolated operation, these approaches are not enough for building a resilient island power system. In this paper, a two-level MILP BESS sizing model is proposed to transform a island power system into a flexible and resilient microgrid, aiming to maximize the critical load supplied in required duration, also to minimize the total cost at the same time. The seasonal PV power output profile and load profile are derived from the operation records of Orcas Power & Light Cooperative (OPALCO) and utilized in model validation and case studies. The sensitivity analysis between BESS sizing and PV integration capacity indicates that the consistency between PV profile and load demand profile has a great impact on how PV capacity may influence BESS sizing. Further, the resilience improvement brought about by the installation of BESS is quantified through a set of resilience metrics.



Figure 67: US Rural Pilot Site from OPALCO website

## Social Impacts

It created a direct useful case study to expand BESS size across OPALCO islands to sustain against frequent outages that lasts few hours and provides viable options for improving the system resilience improvements during extreme weather-related outages.

## 4.4.2 Lab Test Beds

Various R&D results and algorithms developed in the project were tested through off-line simulations and on available real time simulators. It is very much necessary to further validate these algorithms through Control Hardware in the Loop (CHIL), Hardware in the Loop (HIL) and Power Hardware in the Loop (PHIL) experimentation using a laboratory test bed such that some of them can be tested in the actual field.

In view of this, 12 lab test beds were developed, 6 each in US and in India as shown in Figure 68. The six lab pilots developed in India include -

1. IIT Madras: Dynamic Energy Management System for Grid Interactive Microgrid with Hybrid Energy Storage
2. IIT Roorkee: AC-DC Hybrid Microgrid Testbed
3. IIT Kanpur: Reconfigurable Distribution Testbed & HIL Validation
4. IIT Delhi: Microgrid Testbed
5. IIT Bhubaneswar: HYBRID AC-DC MICROGRID TESTBED
6. TERI: Smart Controller Lab Testbed

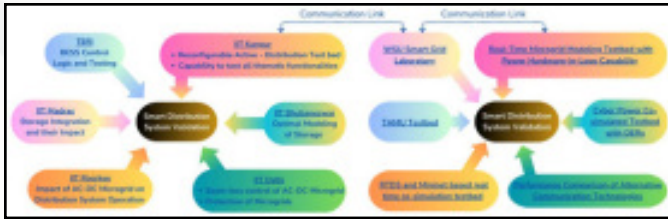

Figure 68: UI-ASSIST Lab Pilots

4. Addressing power quality issues while connecting the microgrid system to the ac grid.
5. Energy management schemes for the operation of the integrated microgrid system consisting of renewable energy source, hybrid storage, load, and ac grid system.

### Future Possible Research Works

1. Research has been carried out on testing various optimization schemes and topological changes to improve the overall performance and reduce costs and losses on the developed microgrid system.
2. Use of both batteries and supercapacitors in electric vehicles with optimization of various performance parameters is to be tested on the developed microgrid system.

## 4.4.2.1 Lab Testbeds in India

Brief details of the 6 lab test beds lab in India are given below

### A. IIT Madras Lab Testbed

#### Technical Details

A microgrid test bed system is being developed at IIT madras, consisting of the following units.

1. A PV system
2. DFIG and PMSG based wind turbine emulator.
3. A hybrid energy storage system consisting of battery and supercapacitor units.
4. Various DC to DC converters to integrate PV, battery, and supercapacitor units to the DC bus of the microgrid system.
5. AC to DC converter to interface the wind energy system to the DC bus.
6. Voltage source converter to integrate the DC bus of the microgrid to the main distribution grid.
7. A digital platform to implement the control schemes for above mentioned converters to achieve appropriate power flow and maintain power quality requirements while supplying the load reliably.

#### Key Research Works Carried are

1. Development of integration of renewable energy source emulators
2. Development of hybrid energy storage system consisting of batteries and super capacitors
3. Control schemes for voltage source inverter of the microgrid system under various operating conditions



Figure 69: An integrated microgrid system with various renewable energy sources and storage units

### B. IIT Roorkee Lab Testbed

#### Technical Details

The Testbed infrastructure involves:

1. DC microgrid test set-up with HESS, namely lead-acid batteries, lithium-ion batteries and supercapacitor, electronic loads, PV (both rooftop and emulators)
2. AC microgrid test set-up with 2.2 kW wind emulator and 7 kW grid interfaced PV inverter.
3. Further facilities like RTDS, Power amplifiers, OPAL-RT, FPGA-based WAVECT controllers, etc.



## Key Research Works Carried are

1. Investigation of damping effect of grid synchronization loop on low frequency harmonic stability of grid-tied inverter with different current control schemes.
2. Investigation of relationship between harmonic stability and harmonic attenuation in multi-parallel inverter systems followed by trade-off design approach to improve them.
3. Investigation of integration of attributes like voltage regulation, active/reactive power support of distribution systems.
4. Study of distributed control algorithms for standalone cyber-physical DC/AC microgrid systems and the effect, detection, and mitigation of cyber vulnerabilities on them.
5. Design and development of decentralized power flow algorithms for hybrid AC-DC microgrids.

## Future Possible Research Works

1. The study of autonomous cyber physical microgrids can be extended to study of self-healing characteristics exhibited by networked microgrids in distribution/power grids.
2. Proper modelling of communication networks interface with the existing hardware.
3. Exploring other forms of harmonic instability considering alternate inverter control schemes.



Figure 70: AC-DC Hybrid Microgrid Laboratory test bed

## C. IIT Kanpur Lab Testbed

### Technical Details

The Testbed infrastructure involves:

1. Grid Emulators.
2. Line Modules.
3. Load Modules
4. Solar Modulators.
5. Real Time Simulators namely RTDS, Opal-RT and Typhoon.

### Key Research Works Carried are

1. **Microgrid Integration in Smart Low-voltage Distribution System:** Describes a concept to convert the Low Voltage Distribution System into a Smart Microgrid.
2. **Grid Integration of Small-Scale Photovoltaic Systems in Secondary Distribution Network- A Review:** Presents a review of technical knowhow required to integrate small PV system into the microgrid.
3. **Wide Power-Bandwidth Power Sink (WBPS):** It proposes a method to emulate a small home in the lab. Modern homes can sink at various times of harmonics due to predominance of electronic equipment used, which are a major source of harmonic pollutant.
4. **Power Hardware-in-Loop Interconnection Issues with Real Time Digital Simulator (RTDS):** Explains the challenges of using RTDS in PHIL simulation. The paper relates the time delay in feedback commutation on the stability of the PHIL simulation. The resulting paper is under review.
5. The test bed was used to simulate the rural microgrid under UIASSIST project in the lab.

### Future Possible Research Works

Developing products and collaborating with industry was not an objective of this project. However, we have collaborated with other partners to validate some of their work. For example, the testbed was used for microgrid validation of TERI. Further work was done with WSU to establish remote connectivity of RTDS at the two Institutes and perform co-simulation studies.

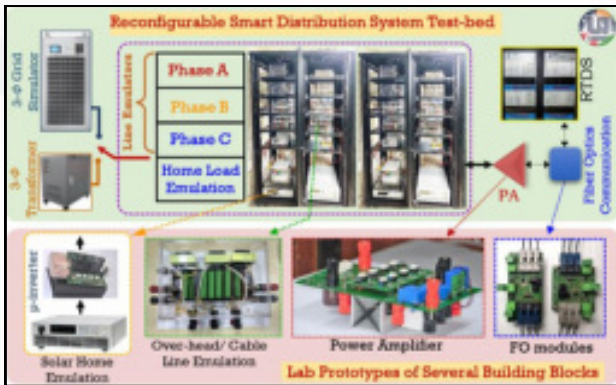

Figure 71: Overview of the LV distribution system test bed

## D. IIT Delhi Lab Testbed

### Technical Details

1. The Testbed infrastructure involves: Real-time simulators like RTDS, OPAL-RT, and Typhoon 602+ that are interfaced with the physical devices according to the requirement of the experiment.
2. A 15-kWh Li-ion battery model
3. Microgrid Setup.

### Key Research Works Carried are

1. Anti-Islanding Protection Strategy Implementation
2. Power Management Strategy of Grid-tied DC Microgrid including Battery Energy Storage Systems
3. Improved current and voltage control: Robust Backstepping Method
4. Improved transformation of natural (abc) frame signals to double synchronous reference ( $dq\pm$ ) frame
5. Improved performance for VSCs serving unbalanced loads.

### Future Possible Research Works

1. Implementation of Anti-islanding Protection Algorithms.
2. Stability evaluation and testing of stability enhancement strategies of IBRs.
3. Fault studies on the IBRs with GFL/GFM control architecture.

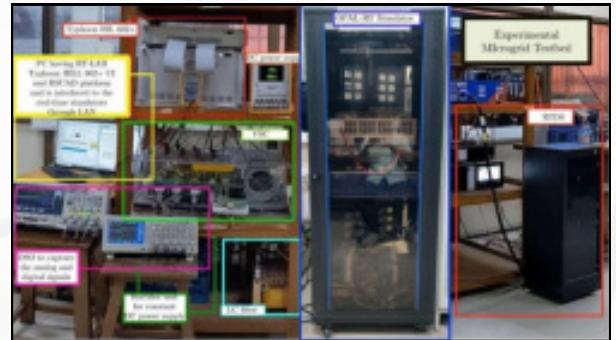

Figure 72: Testbed for real-time validation of an Anti-Islanding Protection Scheme of IBRs

## E. IIT Bhubaneswar Lab Testbed:

### Technical Details

The Testbed Infrastructure Involves: A 50 kW microgrid testbed as shown below is developed at IIT Bhubaneswar laboratory. The DC side energy sources consists of a 10 kW Solar emulator, 5 kW Fuel cell emulator and a 55 kWh Li-ion battery bank. All these DC sources are connected to a DC distribution panel at 380 V.



Figure 73: Architecture of the testbed

The AC side energy sources consist of a 10-kW synchronous generator, a 10 kW Doubly fed induction generator-based wind farm and a 5 kW Permanent magnet synchronous generator-based wind farm.

All these sources are connected to an AC distribution panel operating at 3-phase, 415 V and 50 Hz frequency rating.

## Key Research Works Carried are

1. PV, load with battery storage system for voltage regulation and energy management has been performed by using the testbed.
2. Fuel cell with load and battery charging and discharging has been performed.
3. All the modules were tested individually in stand-alone mode.

## Future Possible Research Works

1. In the future, all the modules will be tested by connecting all the sources and loads at a time and the total system will be controlled with new control and protection algorithms.
2. The bidirectional DC/DC converter can be replaced by novel isolated DC/DC converters.
3. Reliable protection and control techniques and modulation techniques will be built and tested on the testbed.

## F. TERI Lab Testbed

### Technical Details

The Testbed Infrastructure Involves:  
The lab is equipped with a Grid Simulator, PV Simulator, Battery Simulator, and Load Emulator that provide a realistic testing environment.

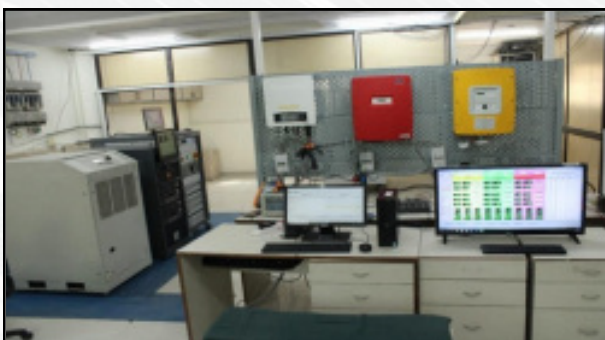

Figure 74: TERI Smart Grid Control Lab Test Bed

## Key Research Works Carried are

1. Interfacing of grid simulator, load emulator, and battery simulator on a common integrated platform-LabVIEW for remote monitoring and control.

2. Hardware-in-the-loop (HIL) testing and validation of results obtained from MATLAB Simulink models.
3. Testbed configured and key parameters like grid power, load power, battery SOC, reference voltage for charge/discharge and grid/load current are being monitored.
4. A program developed for real-time programmable operation of battery simulator using LabVIEW and NI controller cRIO-9074 for testing BESS control logic of distribution transformer peak shaving application.
5. Created and simulated Taimoor Nagar feeder network in MATLAB based on data obtained from field measurements. The network was modelled in MATLAB and consequently, battery charger (DC-DC converter) was designed for DT overload management. The controller trigger actions provided to bidirectional DC-DC converter (battery charger) are being decided on real-time power flow monitoring as well as status of battery and accordingly switching pulse is being given to buck-boost converter. The simulation results obtained show that the DT loading has been restricted up to a certain level (80% of DT rating).
6. A BESS operational control scheme incorporating the Loss of Life (LOL) model of a distribution transformer was developed and tested in MATLAB Simulink. DT LOL estimation model developed as per IEC 60076-7-:2005 & IS 2026 (part 7:2009).
7. Model developed for specified type of DT (ONAN). The model takes ambient temperature and real-time loading as input parameters to estimate the LoL of DT.
8. Li-ion (3.2 V, 100 Ah LFP) cell testing (without thermal chamber) has been performed to determine its energy capacity. The cells have been received from BHEL under BESS pilot project.

## Future Possible Research Works

1. Cell/battery testing, life cycle and performance assessment of cells/batteries with different chemistry.
2. Drive cycle test of EV batteries with thermal monitoring using thermal chamber.
3. Charging/discharging (V2G and G2V) impact on distribution networks.

## Possible utilization of facilities by the outside organizations

- Master/Ph.D. students from academic institutions can utilize the testbed to perform microgrid simulations and hardware experimentations.
- The system can be used by any other institute to simulate microgrid concepts in low voltage distribution grid. It includes various power system test conditions such as fault, voltage sag/swell, and frequency variation, etc.

### 4.4.2.2 Lab Testbeds in US

Power grid is undergoing rapid transition from passive to active in nature by accommodating local controlled generators, storage systems, electrical vehicles, controllable and sensitive loads. The active distribution grid landscape embraces a wide variety of new tools /software /modules for operating in a more reliable and hassle-free manner even during extreme conditions. New ideas or techniques were analyzed with respect to desired performance using offline tools and tested with distinct test rigs from various organizations well before the deployment in the field.

#### A. WSU Lab Testbed

##### Technical Details

The Testbed Infrastructure Involves:

The lab is equipped with two distinct real time digital simulators, protection devices, controllers, PMUs, micro-PMUs, and NI RIOs for validating developed techniques or solutions from different themes.

##### Key Research Works Carried

Real time digital simulators (i.e., RTDS and OPAL-RT modules/racks) are used to model EMTP blocks for various components required in microgrids or distribution systems to test and validate the proposed schemes or models. Further, communication protocols and channels implemented using Mini-net and NS3 software for co-simulation. This co-simulation platform is being used for analyzing the cyber and physical threats or events and anomalies.

##### Key activities are

- Real-time simulation digital twins are validated.
- Testing of storage and DER models integrated distribution systems
- Cyber-physical co-simulation analysis of DER connected distribution systems
- Controller -in-loop and Hardware-in-loop validation for volt-var control scheme and event data analytics
- Federated testbed development among partners such as WSU-IITK, WSU-NREL

## Future Possible Research Works

- Establishing the connection between smart city lab and real-time digital simulation lab to demonstrate potential distribution and building automation.
- Testing of autonomous grid operation with high penetration of DERS and edge controllers.
- Performing multi-rate co-simulations among phasor domain and EMTP domain simulations.



Figure 75: (a) Federated Testbed, (b) Real time testbed at WSU

#### B. WVU Lab testbed: Cyber Power Co-Simulation Testbed with DERs

##### Technical Details

This testbed is part of a development of cyber-power co-simulation platform utilizing OpenDSS as a power network and Mininet as a cyber network, integrated with distributed coordination and cyber-attack modelling. The developed testbed can analyse distributed control/optimization application performance during cyber-attacks and a feedback-based Volt-VAR optimization algorithm is utilized as a use-case. Three cyber-attack scenarios, MitM, DoS, and Replay Attack have been modelled to analyse the performance of the utilized use-case. Figure 76: OpenDSS and Mininet based CPS co-simulation testbed shows the general architecture of the model. While our text examples show that the algorithm is unable to maintain the reactive power profile in the event of an attack, the possibility of dividing the network into subsystems in the event of an attack and disabling VAR injection from the controller at the infected host would ensure better performance than a centralized controller.

As shown in the architecture, the CPS testbed has three major functioning layers: Power System layer, Cyber layer, and Application layer. The details are provided in the following,

## A. Power System Layer

The power system layer is built around OpenDSS as a realistic tool for 3-phase unbalanced distribution system modelling, assuming the system's dynamics are slow enough that the overall control process can be represented as a quasi-static process. Co-simulation capabilities and support of the communication interface (COM) of OpenDSS have been utilized here to simulate a time-varying system. Here, the measurement from OpenDSS is fetched through the COM interface into the other layers for generating the control signal. Subsequently, a new set of control signals are deployed to OpenDSS again through the COM interface. Afterward, OpenDSS solves the power flow to generate measurement for the next time step. A set of wrappers coordinates this entire sequential process. While the use of a quasi-static process to represent power system dynamics has an immediate advantage in avoiding time-synchronization among multiple layers of co-simulation platform. However, to alleviate the overall disadvantages of modelling power systems as a slow dynamical system can be alleviated by using an appropriate real-time simulator, which is still a work-in-progress.

## B. Cyber Layer

To enable communication among DER controllers in a distributed fashion, every power system node in the power system layer is represented by a Mininet host in the cyber layer. The hosts are emulated as bash processes, and each host will have its own private network and can only see its own processes. As a result, the host can run any application without the interference of other hosts. This perfectly mimics the real-world scenario where each power system node runs a distributed control algorithm in its own computing device, which is represented as a Mininet host. Mininet host gets its corresponding power system node data whenever required, which, as already discussed, is achieved through the python wrapper facilitated by the COM interface of OpenDSS. Then when it comes to data exchange among different power system nodes via communication network, the Mininet hosts of those corresponding nodes use the Mininet network. We rely on interprocess communication for message passing among hosts, given hosts in Mininet are emulated as bash processes. We have used sockets for this communication as it allows us to create custom network packets. This customization is necessary for distributed control applications as the necessary data can be easily exchanged among the participating hosts as network packet payloads through socket communication. In this work, we have used Mininet Python API to create the cyber network of the given power system network from its graph network topology with a one-to-one mapping between both networks.

This one-to-one mapping is essential to facilitate any distributed control application in the corresponding cyber layer of each power system node. Also, this has made the implementation of a cyber network scalable for any large distribution system while maintaining the geographical sparsity attribute of each distribution system node. Here, we have assumed that the communication channel among the hosts is fixed, which may not be justifiable in a realistic scenario. We are working to alleviate this problem, and it is work-in-progress.

## C. Application Layer

Here, the application layer has three applications that can run in individual host as required, as discussed in the Cyber Layer model. Considering the distributed VAR control application as a use-case, the distributed coordination application is suitably updated to facilitate communication among neighboring DERs.

## Key Research Works Carried

- A quasi-static power network is modelled using OpenDSS, and a realistic cyber network is modelled using Mininet.
- A distributed coordination algorithm using network communication has been developed to aid distributed applications such as distributed Volt- VAR control to determine the connectivity of distributed controllers.
- The entire co-simulation testbed is integrated together using a wrapper developed using python. Two cyber-attack scenarios, namely, the Man in the Middle and the Denial-of-Service, have been appropriately modelled to test the performance of the considered control/optimization algorithm.
- We have shown the efficacy of our testbed while simultaneously analysing the performance of the distributed control algorithm utilizing an IEEE 13-node 3- $\phi$  unbalanced distribution network, with a feedback-based VoltVAR optimization algorithm as a use-case

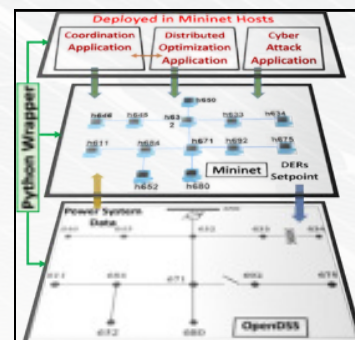

Figure 76: OpenDSS and Mininet based CPS co-simulation testbed

## C. Lab Testbed at HNEI

### Technical Details

The real time testbed at HNEI has the following components to perform validation of PV estimation models, smart inverter functionalities and other associated research.

1. Figure 77: Block diagram of HIL test lab with four PV sub-arrays and inverters that can be switched between the actual grid and an emulated grid using power amplifier and real-time simulator.
2. Figure 78: Picture of custom-developed power monitor with embedded real-time analysis and control capability. Includes FPGA, GPS receiver with high time precision, quad-core 64-bit ARM processor, and various comms.
3. Figure 79: Diagram of publish/subscribe communication used by power monitoring and control system.

Figures were combined and adapted as needed to be specific to UI-ASSIST use cases.

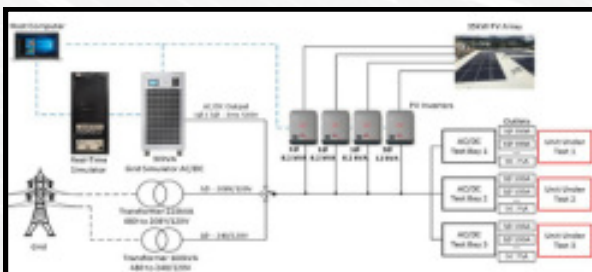

Figure 77: HIL testbed block diagram



Figure 78: Custom-developed power monitor with embedded real-time analysis and control capability

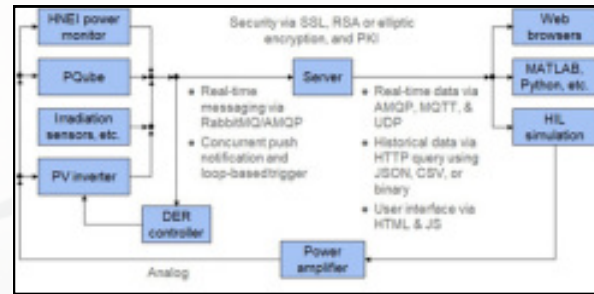

Figure 79: Communication architecture

## Key Research Works Carried

- Validation of solar PV estimation models
- Behind the meter solar PV penetration impacts on distribution systems.
- Solar data interface with real-time simulation models

## D. Burns and McDonnell Smart Grid Lab

It is capable of demonstrating the interoperability of software, two-way communications equipment, and other automation equipment in preparation for deployments of Smart Grid projects. This lab can be used in simulating two complete substations and varying power conditions. Additionally, alternative communication technology will be tested and validated using this lab.

### Technical Details

A photovoltaic AC output (W) data .csv file will be sent via a fiber link from the “field” to the “control center” (real world conditions to be simulated through the use of an extensive fiber link). Data rate, round-trip latency, packet loss and jitter will be calculated for this communications link. These metrics will then be compared to the metrics of a second communications path. This second path will consist of a few links:

- A laptop with the stored AC output (W) data connected to a 700 MHz radio (remote station)
- The remote station 700 MHz radio connected to a second 700 MHz radio (base station)
- The base station 700 MHz radio connected to another laptop (intermediate SCADA)
- The second laptop connected to a Sub SCADA Server/Sub MTU

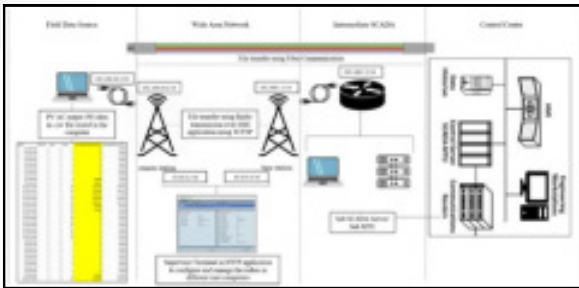

Figure 80: B&McD testbed architecture

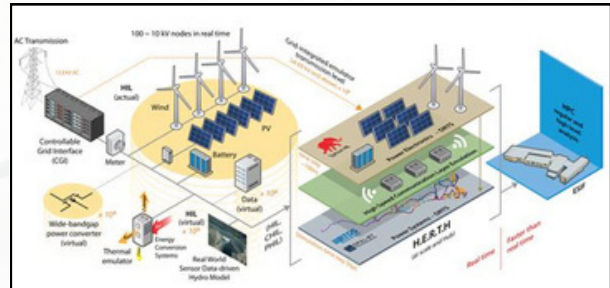

Figure 81: NREL testbed

## Key Research Works Carried

- Verified the accuracy of the data rate and round-trip latency ranges by determining an exact value.
- Expand on the metrics being analyzed by also quantifying values for packet loss and jitter.

## Future Possible Research Works

Federated testbed can be made available through possible connection of one or more laboratories from different partners to expand system capacity and enclose different components of the system for exploring distinct case studies or scenario testing with cyber/communication layer.

## E. NREL Lab Test Bed

Real-Time Microgrid Modeling Testbed with Power Hardware-in-Loop Capability will enable researchers, academics, and practicing engineers from electric utilities to leverage advanced digital real-time simulation (DRTS) along with Hardware-in-Loop infrastructure to enable a wide-range of experimentation and testing related to microgrids.

HIL-capable real-time microgrid models, this testbed is also capable of measuring the microgrid's performance and resilience. The setup is capable of other use-cases like volt/var control and microgrid energy management.

## Technical Details

US partner developed Advanced Research on Integrated Energy Systems (ARIES) - a research platform that can match the complexity of the modern energy systems - that enables scientists and engineers to collaborate and conduct complex, large-scale research. ARIES represents a substantial scale-up in experimentation capability from existing research platforms, allowing for research at the 20-MW level. The scale of the platform is amplified by a virtual emulation environment powered by NREL's 8-petaflop supercomputer, and its clustered digital real-time simulation (DRTS) capabilities comprising 9 RTDS Novacor chassis, and several Typhoon and Opal-RT assets.

Each NovaCor chassis can model up to 600 single-phase nodes (200 three-phase buses) split over two network solutions as well as component models with additional embedded nodes. With 9 NovaCors, it will be possible  $9 \times 200 = 1,800$  3-phase nodes -- which is enough to support high fidelity modelling of regional-scale transmission, sub-transmission and distribution networks.

With this infrastructure, ARIES is a one-of-its-kind prototyping and development environment for energy systems engineers to understand the impact and get the most value from novel technologies. Using hardware-in-loop simulation, ARIES will enable the project team members with access to a facility to build real-time model of regional-scale power system with 100% mixed IBR penetration, and develop, validate and de-risk protection studies and deliver enhanced protection methods with a roadmap for future transmission systems with high-IBR penetration.

We have extensive experience in testing novel algorithms for power systems with an DRTS systems. DRTS is primarily developed and utilized for hardware-in-the-loop (HIL) testing of protective relays, digital controllers, and process control devices for performance evaluation and pre-commissioning testing under close-to-real-world conditions. Also, HIL testing is commonly used for prototype development and/or finalizing a new application design involving several digital control, protection, and measurement devices.

In the testbed, we can connect hardware sited locally in NREL Flatirons campus, such as 1 MWh Battery - LG Chem lithium-ion battery, SMA Sunny Central inverter, 400 V/13.2 kV step-up transformer, and auxiliary UPS system. The developed power systems model can be interconnected with 4,560 100W Cadmium-Telluride thin film PV modules mounted at a fixed 25-degree angle, six grid-tied string inverters, LV AC circuit panel, control equipment and a 600V to 13.2kV step-up transformer. Additionally, the DRTS infrastructure is interfaced with 180 kW linear amplifiers to emulate real world power quality conditions, and 500+ programmable cards, designed to emulate smart electrification-related controllers that can have an impact on the stability and security of the power grid.

### Key Research Works Carried

- Developed notional distribution system in real-time digital simulators
- Performed the lab scale distribution system studies using the WSU campus model in real time simulator and connected actual BESS systems and PV from field through power hardware in loop simulations. Test data was obtained to further conduct research analysis and published the paper.
- Tested nanogrid controller performance.

### Future Possible Research Works

- It must be highlighted that sudden changes in loads and frequencies – which will be common in microgrid power system with 100% mixed IBR penetration - can be best emulated in an environment where there are thousands of electrical nodes, grid-edge devices, and other grid resources connected, in the DRTS environment. ARIES’s environment is a unique environment as it provides this exact environment.



Figure 82: Tested nano grid controller performance testing

## F. TAMU Lab Testbed

### Technical Details of the testbed

This testbed was developed to demonstrate and run tests on a large number of the connected n-Grids. Following are the technical details of the implementation

Block Diagram, Description of Modules and Operating Philosophy of testbed:

The schematic of the n-Grid controller modelled in Typhoon-HIL, the power grid modelled in RTDS, and their connection setup are presented in Figure 83, Figure 84, and Figure 85. Based on Figure 83, the n-Grid model in Typhoon-HIL comprises a controller for an EV charger, a PV, and a fixed Battery storage with their common power electronic inverters. The active and reactive powers consumption/generation of the n-Grid are sent to the RTDS via ETH blocks based on the TCP/IP communication protocol. As shown in Figure 84, the n-Grid is connected to node “n-Grid” in the distribution grid in RTDS. According to Figure 85, the GTNET blocks receive the aforementioned signals and transfer them to the distribution grid in the RTDS. The RTDS runs the power flow in time-domain based on the power signals received from Typhoon-HIL and updates the node voltages and line currents.

### Key Research Works Carried

- Power inverter models are implemented in MATLAB and used in the Use Case of an energy coordination optimization algorithm.
- A data synthetization algorithm is developed using the EV trip data provided in U.S. National Household Travel Survey by U.S. Department of Transportation.



- n-Grid Loading and PV generation scenarios are developed using NREL's OpenEI and PVWatts tools.
- A testbed using real-time simulators is developed where an n-Grid is modeled in Typhoon-HIL and the distribution grid is modeled in RTDS.
- The testbed is enhanced to analyze the impacts of ancillary service delivery by n-Grid aggregation on the underlying distribution grid.
- Transformer loss of life assessment study
- Evaluate the effectiveness of the loss of life mitigation approach proposed.

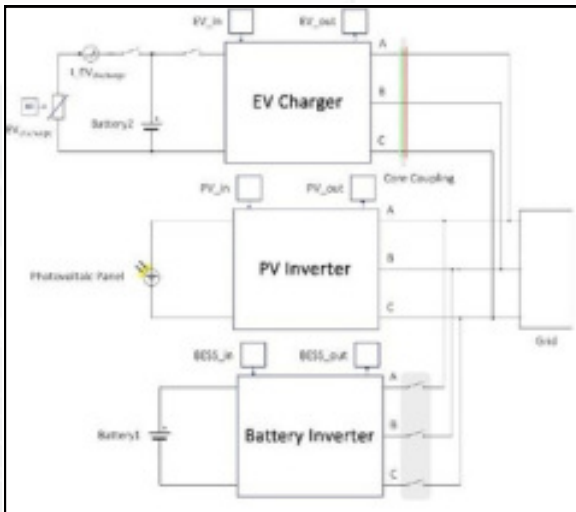

Figure 83: Schematic of the n-grid model implemented on Typhoon-HIL

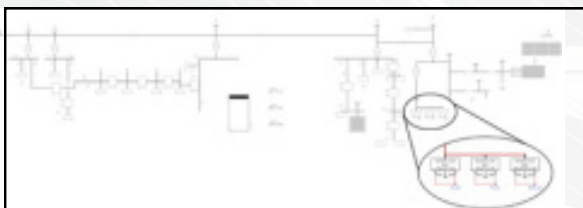

Figure 84: Schematic of the power grid model implemented on RTDS

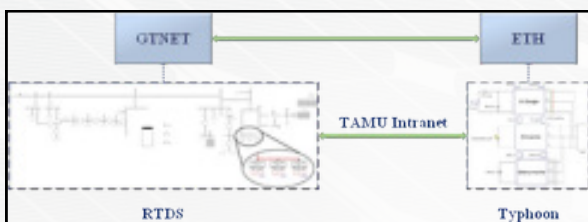

Figure 85: Schematic of real-time simulators connection

## 4.5 Other significant outcomes

### 4.5.1 Benchmark Systems

Several benchmark systems were developed under the UI-ASSIST project which can be used by the researchers working in smart distribution systems area to simulate and validate their R&D activities. Two key benchmark systems are described below:

#### A. Rural Benchmark System

This benchmark system is designed based on the practical data of an Indian village distribution system under the UI-ASSIST rural pilot project in Kanpur. This village distribution system consists of a Radial Distribution System (RDS) with largely dispersed loads of low power rating. A conventional RDS represents downstream power flow, i.e., one power source is at one end of the distribution line, which supplies power to a group of customers. The RDS system is widely used due to its simplicity and cost-effectiveness for a sparsely populated area. However, a power failure, short-circuit fault, or congestion in the power line would interrupt power flow for all the customers.

In the benchmark RDS model, a single pole-mounted distribution transformer is considered for distributing power to the load in the rural area. The power rating of the distribution transformer is 63 kVA, 11 kV/ 415 V with Dvg11 configuration. The ABC pole-mounted cable is used to deliver the power at the load in the rural area. Two types of cables have been used to distribute power. i.e., a three-core 50 mm<sup>2</sup> cable and one core 16 mm<sup>2</sup> cable. Basically, lighting loads and submersible motor load are connected in this village. As this village is remote, the grid is modeled as a weak grid with a 100 MVA short circuit capacity, and X/R ratio is one.

This benchmark was utilized to study the integration of SPV. The main challenge in the design was due to the weak grid. This SPV model includes PV array model, MPPT controller, current controller, voltage controller and transformer. This user defined model was tested with different case scenarios such as loss of grid, over voltage protection and under voltage protection

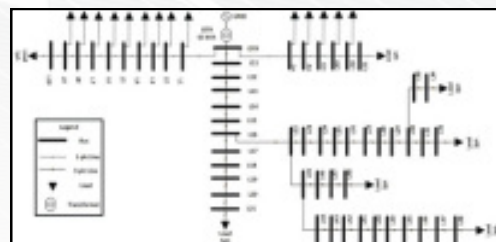

Figure 86: Rural Benchmark System

## B. Synthetic Feeder Model

Most smart grid distribution system algorithms are tested on standard prototype test systems (e.g., IEEE, CIGRE), which are often abstract and may represent some real-world factors. Modifying these standard test systems to fit the specific objective of distribution system analysis requires some work by users to validate those changes. Additionally, these test networks are especially limited in their usefulness when testing for resiliency and post-event restoration algorithms. Synthetic networks with some automated validation building on an existing network or standard network extension can be modeled to capture the complexity of restoring loads in real-world distribution systems more effectively, by factoring in demographic, topographic and historic load information into a single simulation model comparable in scale to the actual system. Thus, synthetic networks can benefit researchers designing smart grid restoration/resiliency algorithms with incomplete information about the energy system complexity. Synthetic networks can be useful for emergency planning teams at utilities, as they would allow for a wide variety of scenarios not feasible in conventionally used distribution system models in existing software tools (e.g., in ETAP, CYME, Milsoft, or SynerGEE). Finally, synthetic distribution networks can also be of interest to transmission planners/operators, because the networks can offer better visibility into how a distribution company is supplying the end-users, and provide insight into how problems in the transmission network can propagate to downstream networks, disrupting critical facilities across a city or a region. The smart grid concept utilizes distributed, intelligent devices and support applications that are intended to improve grid operations by using a communications-driven approach that automatizes the grid response. Since communications play such an important role in supporting this infrastructure, there is an inherent need to model and study the communication entities that operate within this domain. However, due to regulatory provisions intended to protect the grid from malicious actors, most of the architectural information of these systems remains out of reach for researchers. Modeling standard communication links and synthetic cyber infrastructure model will be very important for cyber-physical interdependence analysis.



Figure 87: Schematic of real-time simulators connection

The combined effort of UI-Assist researchers in creating synthetic electrical distribution networks has resulted in a significant number of synthetic models for researchers to choose from, to use in their own work. To aid researchers in selecting a model from those available, we have created a web application to allow them to input their criteria for a model, and receive relevant files based on those criteria. This application is divided into two parts. The first is the front-end interface, written in JavaScript with the Vue 2.6 framework. The second is a minimal backend written in Python.

## 4.5.2 Micro Phasor measurement unit ( $\mu$ -PMU)

### Motivation

With the increase in transmission voltage level and interconnections, power system distribution is becoming more complex, leading towards the need of more digitized solution to revive aging power system. Further, the increase of electrical power demand and rapid integration of renewable energy resources pushes the power distribution systems to operate near their operating limits. Therefore, there is the need for real time monitoring and control of distribution systems. The present trend for real time monitoring is WAMS (wide area monitoring system), which comprises of costly PMUs (phasor measurement units) and (PDC) phasor data concentrators and high bandwidth communication network. The available low-resolution and costly PMUs do not fit for the measurement of distribution network parameters because of highly radial and widespread topology of distribution systems and requirement of large number of costly PMUs to be placed on distribution network.

To address the above challenges, Micro Phasor measurement unit ( $\mu$ -PMU) is considered to be a better option for the phasor measurements in the distribution networks. The  $\mu$ -PMUs are generally utilized in the distribution system to sample voltage and current waveforms in synchronism with a broadcasted time signal. It allows the computed waveform parameters (voltage and current amplitude, phase angle, frequency, and rate of change of frequency) at one location to be compared with those at the other location across a wide geographical area. The  $\mu$ -PMU are developed by very few companies globally. Further, the market leading solutions are highly closed source and proprietary, considerably expensive and require extensive training in a specialized programming environment. The solutions available in the market utilize US GPS for the time synchronization signal. However, there is no solution available in the market which can utilize the NAVIC, an Indian GPS system, for time-synchronization. Therefore, there is a need for a simplified wireless communicating NAVIC -disciplined  $\mu$ -PMU which allows total transparency of signal path and information flow while maintaining a modular platform using widely available, cost effective, and highly documented components. Considering the above aspects, a  $\mu$ -PMU device has been developed at IIT Kanpur by the research team.

## Overview of $\mu$ -PMU

The architecture of  $\mu$ -PMU consists of sensors such as CTs and PTs, Intel Cyclone V FPGA board (a main controller unit), ADC, NAVIC receiver, radio module, and SSD-memory module as its main components, as shown in the Error! Reference source not found. below. Error! Reference source not found. describes the overall architecture of the micro-PMU. The 1pps from GPS provides phase reference for the PLL to generate the sampling clock, which ensures the accurate sampling time instant at different geographical locations. The sampling frequency is selected to be 12.8KHz (256 samples/cycle) for 50Hz system in order to improve the Signal to Noise Ratio (SNR). ARM processor accesses the ADC data through internal shared memory allowing it to be read asynchronously while preventing time delays. The signal processing DFT algorithm for phasor estimation is implemented on sampled data obtained from ADC in the controller unit itself.

The  $\mu$ -PMU device is required at the power distribution level for time synchronized data acquisition. However, the penetration of these devices is very less in the distribution system due to very high cost. The developed solution is very cost effective (only about 30% of the cost of commercially available  $\mu$ -PMU), which will revolutionize the data acquisition mechanism at the power distribution level.



Figure 88: (a) Micro-PMU, (b) Micro-PMU Architecture

## Relevance of the product

The micro resolution phasor measurement device will enable the real time measurement of distribution nodes, which may contain renewables. The real time data will help the operators to avoid contingencies and restore them to the normal state if contingency happens. In India, it is planned to have real-time energy market. The real time data, provided by  $\mu$ -PMU will also be crucial for making and executing the proper energy trading strategy.

## Novelty

The  $\mu$ -PMU is integrated with Indian NAVIC system for time synchronization. It is compliant with IEEE C37.118 standard. It is developed as a low-cost device keeping Indian power distribution system in focus. The ability to measure up-to micro level resolution makes it suitable for measurement of distribution network parameters. The integration with NAVIC for timing and synchronization signal eliminates the dependency on other countries (e.g. USA – for GPS). Further, the  $\mu$ -PMU is also integrated with US-GPS as fallback option. This will help in addressing the GPS spoofing attack.

## Business Model

The  $\mu$ -PMU is built to be integrated in future distribution substations for better monitoring of modern power system. It helps in real time monitoring of the distribution grid. The micro-PMU is an important part of WAMS (wide area monitoring system). It has micro-PMU, communication infrastructure, and PDC (Phasor data concentrator) as their main components. The commercialization of  $\mu$ -PMU will enable the wide area monitoring system for electrical power distribution network. The efforts are being made to incubate a startup in IIT Kanpur to commercialize the  $\mu$ -PMU technology.

## Resilience

The  $\mu$ -PMU will increase the resilience of the modern power grid. The  $\mu$ -PMU device is quite robust and resilient to environment's electromagnetic interferences. The integration with NAVIC for timing and synchronization will make India self-reliant in this area. Further, the integration of US-GPS with  $\mu$ -PMU as fallback option will help in making the  $\mu$ -PMU resilient against GPS spoofing attack.

## Scalability

Being made in India product, the indigenously developed  $\mu$ -PMU technology is highly scalable. The architecture of  $\mu$ -PMU is developed in house. It uses peer to peer network technology for communication and the system on chip (SoC) architecture. This makes  $\mu$ -PMU easily scalable, when commercially manufactured.

## Product Readiness and Testing

Basic prototype of micro-PMU is ready. It is working well in laboratory environment and limited field trials. Various field testing is being carried out and soon it will be ready for commercialization. The Indian patent for the  $\mu$ -PMU is already granted to IIT Kanpur.

## Societal impact

Indian power distribution system is highly stressed and vulnerable to various faults and contingencies. Therefore, there is a need of fast and reliable measurements from the field. Fast and high-resolution measurements can address the above challenge and improve the observability of electrical power distribution system. This will help in better control and operation of the power system and will help in improving the life span of power system transmission and distribution equipment. The deployment of  $\mu$ -PMU will help in getting fast and reliable measurements from the field and, therefore, will help in improving the reliability of the electrical power distribution system for Indian population.

### 4.5.3 DSO White Paper

The increasing penetration of DERs in the distribution network, emergence of prosumers, and availability of granular, real-time data are driving reforms in power sector across the globe. The power sector is also transitioning towards incorporation of automation, information management, control and communication technologies allowing two-way information and data flow from utilities and consumers. India's Distribution Companies (DISCOMs) must adapt to this changing landscape and implement much-needed reforms embracing new technologies and business models to ensure reliable and efficient network operation.

Strengthening or revamping existing entities and, in some cases, adding new players and regulatory approvals are critical to rolling out much-needed reforms. Many countries, such as Australia, USA, Japan, including EU, have embraced the notion of a Distribution System Operator (DSO), an entity that is responsible for the reliable, secure and efficient development, planning, and operation of a DER-integrated active distribution network. Countries are at different stages of development in the implementation of DSO in their power distribution networks with DSO functions driven by the unique needs of each country/region and prevailing market structure.

India's draft National Electricity Policy 2021 (NEP 2021) proposed introduction of an independent entity called DSO for performing real-time operation of distribution system and ensuring secure and reliable supply of power to consumers. The introduction of DSO will be instrumental in bringing the much-needed decarbonization of power sector and contributing to system flexibility to achieve India's ambitious renewable energy targets.

India being a geographically diverse and large country, area-specific needs would primarily drive the evolution of DSO models. In view of the growing importance of DSO in distribution sector in India, a white paper has been brought out by the UI-ASSIST team on 'Transforming the Indian Power Sector- Distribution System Operators: Need, Frameworks, and Regulatory Considerations'. This was launched on 8th May 2023 at MNIT Jaipur and is available at <https://uiassist.org/outcome.php>.



Figure 89: DSO White Paper

In the Indian context, a DSO-like entity can provide the following critical functions:

- Address the challenges arising in the operation of active distribution systems and effectively service the consumers.
- Efficiently utilize flexibility available in the distribution system and behind the meter.
- Ensure synergistic interaction with Transmission System Operator.
- Take optimal network investment decisions.
- Enable use of data analytics for improved system operation.

### The Current State of DISCOMs

Before discussing the implementation of DSOs in Indian context, it is critical to understand whether DISCOMs can handle the challenges of emerging active distribution systems.

While it is difficult to clearly respond with a ‘Yes’ or ‘No’ to the above query, enhanced capabilities with the introduction of new/ redefined functionalities will be required for a system operator to handle future active distribution networks. Existing regulations will need to be modified and new regulations framed to facilitate certain advanced functions.

Providing market avenues for trading electricity commodities of DERs would in turn require a system operator or any DSO-like entity to be ideally neutral and independent. While many existing DISCOMs with their legacy practices will find it difficult, if not impossible, to cater to the needs of emerging active distribution networks, others may be able to transition to DSOs in the future with the help of appropriate structural change and regulatory support. With the diversity of DISCOMs in terms of consumer mix and behavior, DER penetration and potential, and operations and fiscal conditions, the definition or functionality of a DSO would be different in different regions.

## Building Blocks for DSO Implementation

### Technical Recommendations

State-of-art Supervisory control and data acquisition (SCADA) system and software for data acquisition, monitoring, supervision, and control. Two-way strong and redundant communication network between the SCADA system and intelligent devices, such as Intelligent Electronics Devices (IEDs), Phasor Measurement Units (PMUs), and Internet of Things (IoT) devices for addressing real-time visualization, monitoring, and control of the power system network at control centre.

- Advanced Distribution Management System (ADMS) should be flexible and based on a plug and play architecture
- Information and Communication Technology (ICT) should be a full-fledged functional vertical and future technology ready.
- Advanced Metering Infrastructure (AMI) should enable easy sharing of data/information over multiple protocols with different applications
- Multi-layered approach should incorporate cyber security and system theory

### Institutional Framework

Considering the prevailing structure of the Indian power sector and relevant learning from international practices, the following four alternatives of institutional frameworks are proposed

- Separate Non-profit Entity
- Sub-State Load Dispatch Centre (SLDC)/ Area Load Dispatch Centre (ALDC) to DSO Transition
- DISCOM to DSO Transition.
- Repackaging of Existing and New Entities

Due to the diversity in generation and load patterns, ownership, and operation models of DISCOMs, consumer mix, and state-specific regulations, different states will have different considerations for adopting any of the four suggested alternatives. While selecting a suitable DSO option, each state electricity regulatory commission will have to consider the current and anticipated electricity scenario in their respective State, especially the issues and challenges likely to be faced with large-scale penetration of DERs. The prevailing power system structure in a state will also serve as the main criteria for adopting a suitable DSO model.

### Regulatory Requirements

Regulations need to spell out roles and responsibilities of DSOs and other entities having role in/bearing on distribution system operation taking note of emerging trends in end-use (prosumers, EV charging/support) demand response requirements, and cyber security for such active distribution systems.

Three options that may be considered for distribution system operations in the new paradigm are (a) distribution system operation under distribution licensee, (b) distribution system operation under sub-SLDC and (c) distribution system operation through statutory provision.

Existing codes/regulations will need modifications/additions to address new functions and to perform existing functions in the manner or to the extent they need to be performed. These functions include scheduling and dispatch, integrated network planning, cyber security, system coordination, forecasting, market facilitation and allied issues, and resource adequacy.

## Summary of white paper

The DSO white paper provides a detailed roadmap for DSO implementation in India, addressing the technical requirements, institutional frameworks, regulatory requirements, and long-term economic implications. The report is divided into six chapters, the first of which provides a background and an overview of current Indian Power Distribution Sector. A section of the chapter also discusses the initiatives taken by different utilities across the globe to introduce DSOs and associated learnings. The second chapter discusses the challenges involved in transformation of the conventional passive distribution networks into Active Distribution Networks (ADNs) with the integration of DERs, EV infrastructure, and BESSs. It addresses the technical requirements for implementation of various functions envisaged to be performed in ADNs and the perceived role of DSO in the Indian context, followed by definitions of DSO across the globe. Chapter 3 introduces the reader to the proposed institutional framework of DSOs in India.

This chapter suggests four alternatives for introducing DSOs, considering the prevailing structure of Indian power sector and international practices. With the introduction of local level electricity market in Indian power sector, consumers and prosumers will be empowered not only in terms of having a choice of supply but will also have the option to sell it (in the form of demand response) either within the local-level electricity market or participate in wholesale electricity market through an aggregator. Chapter 4 provides an overview of electricity commodity trading opportunities under the DSO set-up. The legal, policy, and regulatory landscape, as well as considerations pertinent to distribution system management, are presented in chapter 5 with a view to understanding the organization of core activities and the way they are conducted under various legal and regulatory considerations. Based on the review of existing national and international learning and studies presented in the preceding chapters, recommendations on technical, regulatory, institutional manpower and skill requirements aspects, cost-benefit analysis, and implementation plan of DSO are presented in the final chapter.

**The introduction of DSOs can be a game-changer in transforming the operational and financial state of Indian power sector and boost private sector's confidence attracting much-needed investment and innovation in the industry. Regulators and utilities need to come forward to facilitate this transition that will ultimately result in the efficient operation of the overall distribution grid.**

## 4.5.4 Resiliency Assessment Tool for Active Distribution Network

For multiple stakeholders, given an observed increase in severe weather events in recent years and impact on the power distribution grid. Distribution network operators need to assess and analyze the resiliency of the system through carefully designed visualization driven by data and model-based analytics. Operators require real-time data visualization of system states and resiliency indicators to make correct operational decisions and to control actions to minimize system impact. We worked on a resilience-driven visualization tool, the Real-Time Resilience Management System Tool (RT-RMS), developed to assist operators in decision making and resilience assessment. RT-RMS utilizes multi-dimensional resilience metrics, geospatial visualization, and data monitors assessing resilience indicators and other key data points we discussed the basis of design, design considerations, open-source software components, and use cases demonstrating implementation and discusses the importance of the presented tool, especially in geographically isolated communities, where resilience is valued more than economic operation. The challenge of handling large amounts of data in a web-based application is analyzed by implementing a three-layered architecture and applying RESTful APIs in the back end. Case studies are presented to highlight key RT-RMS features.

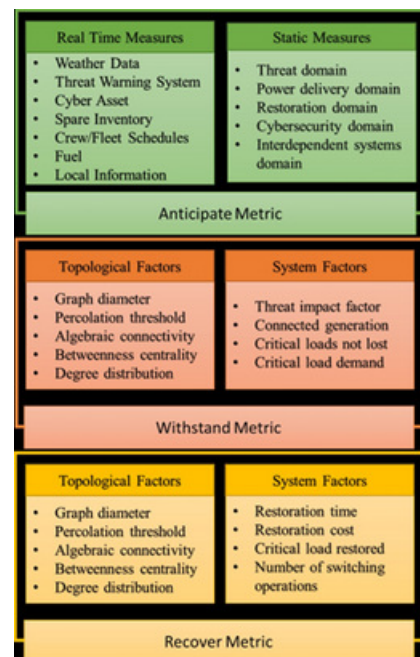

Figure 90: Summary of the Anticipate, Withstanding and Recover (AWR) Resilience Metric

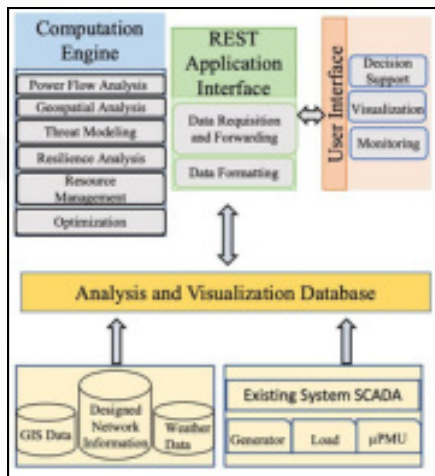

Figure 91: Overview of the RT-RMS Dataflow Architecture



Figure 92: RT-RMS Console: Pre-event alert mode

## 4.6 Highlights of US-India Collaborative Activities

- US and India team worked on a cooperative framework for an electric vehicle fleet to address voltage quality issues on rural grids. This work proposed a framework to address the voltage quality of rural distribution system with solar PV rooftop units by leveraging electric vehicles as virtual storage system through charging station. This has been tested and validated on IITK Rural field pilot.
- US team worked on the development of microgrid clusters in the real time digital simulator (RTDS), for validation of centralized and consensus-based control approaches from both US and India teams. These two clusters were connected to an IEEE 13 node distribution system for making the modified benchmark model as one of use cases in validating two-layer volt-var control methodology.
- US and India teams collaborated on an effective control and management scheme of Isolated DC Microgrids. The Isolated DC microgrid consists of an internal power management scheme (PMS) responsible for effective power sharing (primary and secondary level controls) among distributed energy resources like diesel generator, photovoltaic panel, battery, and supercapacitors. Additionally, when integrated to the grid, the Microgrid is enabled to assist the distribution utility for uniform voltage regulation in the distribution feeder. This was achieved through a coordinated control strategy between the Advanced Distribution Management System (ADMS) of the utility and the Microgrid Management System (MEMS) of the DC microgrid.
- US and India teams worked together on fault location framework which consists of three steps: detecting, classifying, and locating the fault in the active distribution system. The proposed method reduces the search area by using the sending-end sample value of the line current. It can be implemented in a distributed form without knowledge of system parameters using pole-mounted data recording meters and relaying the approximate fault location and type to the control center. The proposed framework is tested using an IEEE 13-node test feeder with a solar photovoltaic system. Different training parameters for the CNN are also tested to analyze the proposed framework.
- Benchmarking rural feeder and semi-urban pilot models developed by India team have been tested at US team for validating the different research and development outcomes utilizing synthetic benchmark platform.
- IITK rural benchmark has been co-modeled in ETAP, Gridlab-D, and OpenDSS software for cross validation. A comparison of results in different software has been performed by joint team members. Rural benchmark model and simulation results are being reviewed and validated by a IEEE PES subcommittee to allow it to be published as IEEE PES benchmark microgrid model. The approval process is in progress.

- US and India teams collaborated on examination of the impact of DG penetration on short circuit capacity and bidirectional power flow, analysis of unnecessary tripping and sympathetic tripping phenomena. Next, they investigated unintentional islanding and the challenges of integrating different types of DGs. This lead to recommendations for potential protection measures and adaptive relaying schemes for improved performance in microgrids.
- US and India teams modeled the physical network and communication network of an interconnected DC MG clusters in RTDS and Mininet. The presence of an attacker either disturbs the consensus operation or leads to convergence to non-optimal operating points in the presence of stealthy attacks. Proposed detection mechanisms from the physical network side are to provide proper mitigation actions.
- US partner have finalized cyber auditing of IITK and TERI field pilots to provide recommendations to enhance cyber security of all the vulnerable devices in the distribution systems.
- US and India teams worked together on developing the cyber-physical co-simulation testbeds for interdependent system analysis in case of vulnerabilities.
- US and India teams worked jointly on demand response scheme and proposed a utility-user cooperative algorithm (UUCA) for application of flexible load scheduling demand response analysis.
- Student interns worked on solar smoothing for Arlington microgrid. The problem was formulated as an Optimal Power Flow (OPF) to mitigate SPV forecasting errors for the Snohomish County Public Utility District (SnoPUD)'s Arlington Microgrid. Real world datasets have been used for testing and validation of the developed approach for the Arlington Microgrid with two test cases 1) grid connected mode and 2) islanded mode of operation.
- US partner dedicated effort to advancing forecasting methodologies, harnessing the power of data-driven techniques. US partner collaborated with India under the UI-ASSIST to expand this effort to an international context, by applying our existing modeling methodology to load data from India for a specific application.

The research work delved into a comprehensive comparison of six distinctive short-term load forecasting models specifically tailored for a distribution transformer. Out of the models tested, five were selected by India team, encompassing a mix of statistical and machine learning models, and applied by India partner to their dataset. US partner, on the other hand, contributed its own load forecasting model, which notably outperformed the other models in accuracy. Paper was just published in IEEE conference,

- US and India team worked on distribution transformers overloading mitigation using smart coordination between PV generation, battery energy storage and EV charging and paper was also accepted at CIGRE 2023 conference.
- US and India teams collaborated in implementing, testing, and validating centralized and distributed volt-var control schemes with IEEE benchmark systems.
- US and India teams collaborated to develop a PHIL demonstration of MIT's distributed optimization algorithm, PAC.
- US and India team worked collaboratively to build federated co-simulation testbed by leveraging geographically distributed laboratory facilities in USA and India. This setup was used to test and validate the large system fault response with DERs. Analyzed the effect of data rate on the accuracy of the power measurements at the connection of the two test systems and finding the effective data rate for co-simulation. Models were considered with BESS and Solar PV and exchanged between IITK and WSU. US-India federated Testbed was the first of a kind testbed where data is transferred at such a large distance, and it studied the performance of the co-simulation with respect to the data rate. In this testbed setup, transmission and distribution system were simulated in RTDS placed at two different geographical locations. A schematic of data exchange in federated testbed is shown in Figure 93.

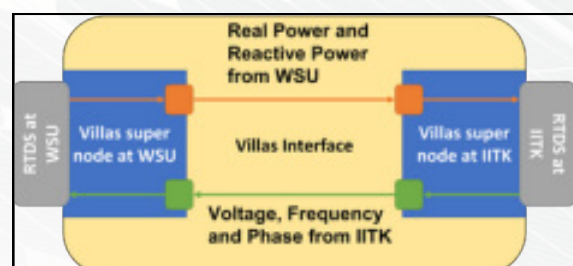

Figure 93: Villas interface for federated co-simulation





- US and India teams collaborated in developing the federated cyber-physical simulation testbed to validate various control and cyber resilient approaches for microgrids connected distribution systems.

---

## 4.7 Capacity Building

At present, the electrical power distribution is witnessing transformational changes in terms of technology intervention. The future distribution system will be smarter as well as more technology oriented for better monitoring and control. The UI-ASSIST project was envisaged to develop the future smart distribution concept where DERs and storage play a major role. To understand and work on the future technologies, suggested in the project, huge skilled manpower support is required. Therefore, multiple trainings and workshops were organized during last six years to train such manpower.

Few key initiatives taken to train the manpower are described as follows --

1. Webinars
2. Seminars
3. Students Interactions
4. Student Colloquia
5. Workshops
6. Training Programs
7. Students Engagement
8. Student Exchange
9. Faculty Exchange
10. Team Meetings
11. Expert Lectures
12. Summer Internships
13. Outreach

Although lot of activities were carried out during the project period, some of the key events are highlighted below:

### Webinars –

Considering the importance of webinar in knowledge dissemination to larger audience, various webinar series were organized by India and US consortia members. Few important webinars, in addition to more than hundred students' webinars, are listed below:

- Webinar on “Distribution System Operator (DSO): Emerging need, roles and responsibilities” including panel discussion with central as well as state regulatory commissions, Discoms, Powergrid, NTPC, Academia, Corporate and R & D organizations, etc. was conducted on 24th October 2020

- Expert Roundtable on Policy recommendation for Cyber Security and Cyber Infrastructure in Indian Electricity Distribution System was conducted on 21st September, 2022
- UI-ASSIST team organized regular monthly webinars during the project period including presentations by India and US partners on different topics discussing collaborative research progress from India and US side. These webinars were attended by various stakeholders as well as general audiences. Some of the topics of webinars are as follows:
  - Design Guide for Microgrid Protection with Deep Deployment of DER, Inverters and Other Digital Devices and Systems
  - A comparative study of UI-ASSIST Developed Volt-Var Control Algorithms on AVISTA's test system.
  - Nano-Grid Participation in The Wholesale Electricity Markets: Challenges and Opportunities
  - Voltage Control Architectures in Electrical Distribution Systems in DER
  - DC Microgrid Operation with Centralized and Distributed Algorithms
  - Novel Relaying Techniques for Distribution and Microgrids
  - The Future of Electric Power in the US
  - A comparative study of UI-ASSIST Developed Volt-Var Control Algorithms on AVISTA's test system.
  - Nano-Grid Participation in The Wholesale Electricity Markets: Challenges And Opportunities
  - Energy Storage System Models & Applications
  - India and US Efforts on Markets, Policy & Technical Standards related to Advanced Distribution Systems and Microgrids
  - Estimating Behind the Meter DER and Analysing Impact on Load
  - Alternative Communication Technologies and cybersecurity in DER-RICH Systems
  - Modelling of AC Microgrid with DER for Protection in Distribution Grid Operation by Simulation Analysis

- US-India Federated Testbed: Impact Analysis of Communication Rate on T&D Co-Simulation during the Fault
- Design Guide for Microgrid Protection with Deep Deployment of DER, Inverters, and Other Digital Devices and Systems
- Voltage Control Architectures in Electrical Distribution Systems in DER

## Outreach

Although India and US consortia members conducted various outreach programs on a regular basis, only key activities are highlighted below:

- India and US consortia partners presented UI-ASSIST activities in various panels of different national and international conferences for dissemination of UI-ASSIST work to larger audience.
- Joint efforts from India and US communication team were made for publicizing the key outcomes from each member to reach out to broader audience through linked in, twitter, and Facebook platforms.
- Additionally, interviews and input surveys have been developed to work towards two articles, one on the Women of UI-ASSIST and one on “Where are they now?” for previous UI-ASSIST graduate students.
- Team of Institute Works Department (IWD) representatives were trained on the operation of the Pilots implemented by IIT Kanpur inside the campus.



- People of Harnoo village were familiarized with the benefits and operation of Biomass system installed at Bargadiya Purwa as a part of Rural Field Pilot implementation.



## Training Programs

Following key training programs were organized to share project learnings with key stakeholders in electrical power system domain:

- Training Program on Smart Grid Components and Technologies at IIT Kanpur, 24 – 26 February, 2020.
- Organized trainings to various ITI diploma holders on Solar PV systems, jointly by IITK and Shramik Bharti Foundation from 4th February - 20th March 2021
- Training Program on Intelligent Power Transmission and Distribution Systems, at IIT Kanpur, 18-22 May 2022
- Training program on “Smart Distribution System and Storage” at IIT Kanpur, April 28 – May 02, 2023.

## Workshops

- Workshop on ‘Smart Grid Technology’ 13-14 February, 2019



- US Team Second Annual Meeting 12-13 June, 2019, Spokane WA.



UI-ASSIST Joint Meeting/Workshop 18-19 December, 2019, New Delhi, India.

The objective of this workshop was to familiarize the participants from the regulatory organization, load dispatch centers, utilities, and R&D organizations with different operational, regulatory, reliability, and security challenges that need to be addressed in deploying renewable and storage integrated smart active distribution systems. The experience gained through R&D activities and pilot deployments under the UI-ASSIST project will also be shared. The workshop will have sessions by speakers from IITs, WSU, WVU, TAMU, TERI, POSOCO, GERC, OPTCL, PSERC, EESL, Burns & McDonnell, VCS, NREL, and Synergy Systems & Solutions.

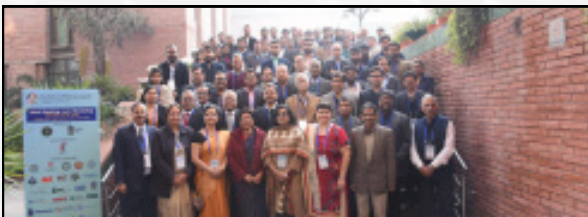

- TERI and IIT Kanpur conducted a 40 days skill development workshop for ITI students in Kanpur during February - March 2021. It was supported by Shramik Bharati Foundation (SBF). In this workshop students were given hands-on training of various Smart-grid technologies to help them support smart-grid development in India. It included field visits to solar implementation facilities, solar panel maintenance, wiring of renewable sources with storage and storage maintenance, etc.



- UI-ASSIST was technical co-sponsor for Power Engineering Research & Applications (PERA), jointly organized by the IEEE PES SBC of IIT Kanpur and IEEE PES UP Section Chapter from 24th to 28th September 2021.
- UI-ASSIST Annual Update Workshop in Denver, 13-15 July, 2022.



- IIT Kanpur and TERI jointly conducted a workshop on “Operational and Regulatory Challenges in DER Integrated Smart Distribution Systems” on 20-21 December 2022 at India Habitat Centre (IHC), New Delhi.
- UI-ASSIST was technical co-sponsor for 3rd National Workshop on Recent Developments In Smartgrid Technologies (NWSGT-2023) - Microgrids and Electric Vehicles on 27th and 28th January 2023.



- ‘Transforming the Indian Power Sector - Distribution System Operators (DSOs): Need Frameworks, and Regulatory Considerations,’ launched during, the Industry Oriented Stakeholder Workshop on Green Powered Future on 8th May 2023 at MNIT Jaipur

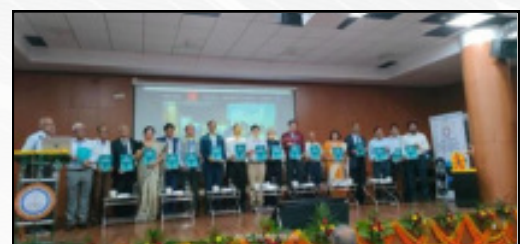

- UI-ASSIST Annual Update Workshop in Florida, 12-14 July, 2023.



- UI-ASSIST workshop on “DER Integrated Smart Distribution Systems: Learnings From Indo-US Project” during September 26-27, 2023

The main objective of this workshop is to familiarize the participants from power utilities, industries, regulatory organization, load dispatch centers, and R&D organizations with different operational, regulatory, reliability, and security challenges that need to be addressed in deploying renewable and storage integrated smart active distribution systems. The experience gained through R&D activities and pilot deployments under the UI-ASSIST project are shared by the consortia partners from India as well as US.

---



The US-India collaborative for smart distribution System with Storage (UIASSIST) project funded under the JCERDC phase-II created a unique opportunity to transform 31 independent entities from US and India into multiple collaborative teams working to translate research and development into practical field demonstrations that create foundational work for clean energy solutions and future distribution systems. Some of the important deliverables of the project are as follows:

1. Detailed modelling in multiple platforms for smart distribution network models integrating Renewable Energy Systems (RES), Energy Storage, secure cyber infrastructure, smart metering, MEMS, ADMS and EV charging infrastructure.
2. Methodology for proper Battery Energy Storage selection, with respect to its type, size, model and placement and developed control logic which was adopted in different field demo pilots.
3. The potential of thermal storage system utilizing phase change material in supporting air-conditioning loads in the building complexes, peak shaving and energy saving was demonstrated through an urban pilot implementation.
4. Multiple advanced converter topology and primary control strategies were developed for integrating RES and storage in the network.
5. Several new schemes of micro-grid controls, optimal operation and protection have been developed which have helped in realizing implementation of next generation MEMS in the field.
6. A new ADMS platform using open platform and CIM database have been developed and its field demonstration for various ADMS/DSO functions has been carried out an urban field demo pilot implementation.
7. Data driven event analytics were developed to provide situational awareness of active distribution systems with high penetration of DERs including Storage Systems and EVs.
8. Different state of the art methodologies for ADMS functions, such as load and solar/wind forecasting, state estimation, Volt-Var control, Network reconfiguration, optimal power sharing and dispatch, TSO-DSO interaction, and Inertial control were developed and some of them implemented on the ADMS platform.
9. A modified reliability framework considering the customer owned DERs was proposed to assist the planning and operation of active distribution systems.
10. A resilience framework to assess distribution system states against natural weather events was proposed and associated tools were developed using open-source software for easy adoption.
11. Nanogrids driven aggregator frameworks to participate in retail and wholesale market was also investigated and recommended practices were suggested through this project.
12. Distributed and decentralized control architecture were developed to supplement ADMS specially for islanded systems after the outage.
13. Various models of emerging distribution/local electricity markets and peer-peer trading have been suggested. A detailed study of the existing DSO models, need and status of distribution system management for different utilities has been utilized to bring out DSO whitepaper which is particularly relevant for its implementation in Indian context.
14. A guideline for the selection of the appropriate communication technology in the field implementation of the smart distribution systems under rural, semi-urban and urban settings was developed.
15. Different methods for detection of cyber threats and their mitigations were developed. Guidelines for cybersecurity assessment were developed for DER-rich distribution systems and cybersecurity audits were performed on many of the field demonstration pilots.



- 16.** Developed resiliency metric tool were used to guide battery sizing and location, switching for restoration after outage considering grid-forming and grid-following inverters and proactive control to minimize the impact of an expected events.
- 17.** The unique lab test beds developed, six each in India and US, have proven to be useful in validated all the R&D concepts before adopting some of them in the field. Platform for co-simulation have been developed and tested along with the utilization of different real-time simulators within a single location as well as distribution of computational tasks at simulators located in India and US. A federated co-simulation testbed utilizing geographically distributed assets in US and India was developed, and various test cases were demonstrated.
- 18.** Multiple state-of-the-art tools and products were developed in the project include.
  - CP-SyNet Tool
  - Cyber & Physical Systems Resiliency assessment tools “CP-SAM and RT-RMOD/RPIA”
  - Real Time Resiliency Monitoring against adverse weather events “RT-RMS”
  - Distribution-PMU based anomaly and event detection tool “D-SyncAED”
  - Microgrid protection, Reliability and Transactive control framework
  - Retail market models
  - Solar PV forecasting web-tool
  - Behind-the-meter load estimation tool
  - Power Amplifier prototype
  - Micro PMU utilizing NAVIC GPS signal
  - ADMS tools
- 19.** Proof of Smart Distribution System concepts were developed in this project and validated through implementation of the ten field demonstration pilots, five each in India and in US under rural, semi-urban and urban settings. These pilots have clearly shown technical merits in terms of increased reliability of supply, and provide 24x7 access to quality electricity supply, in addition to significantly reducing carbon footprint.
- 20.** A new networked microgrid model in rural area for reliable power sharing between villages has been suggested in rural pilot at Kanpur, which electrified two village hamlets originally having no access to electricity.
- 21.** Social impacts of such smart distribution system pilots have been established through extensive pre- and post- installation surveys. These clearly demonstrate social upliftment, specifically in the Kanpur rural pilot in terms of enhanced agricultural yields due to provision of solar irrigation pumps and quality manure from the biomass plant installed in one of the hamlets, enhancing children’s education and local employment due to continuous power supply and setting of local cottage industries.
- 22.** A large number of capacity building and skill development workshops and training programs were conducted for utilities, industries, researchers, and technicians. Future workforce development was achieved by involving a significant number of students, introducing new courses and conducting several webinars.
- 23.** Based on the outcome of R&D activities, stakeholder consultations and experiences through field implementations, several policy and regulatory recommendations have been brought out for larger adoption of Smart Distribution Systems.

The future impacts of the outcomes and deliverables in the UI-ASSIST project are depicted in the following Figure 94.

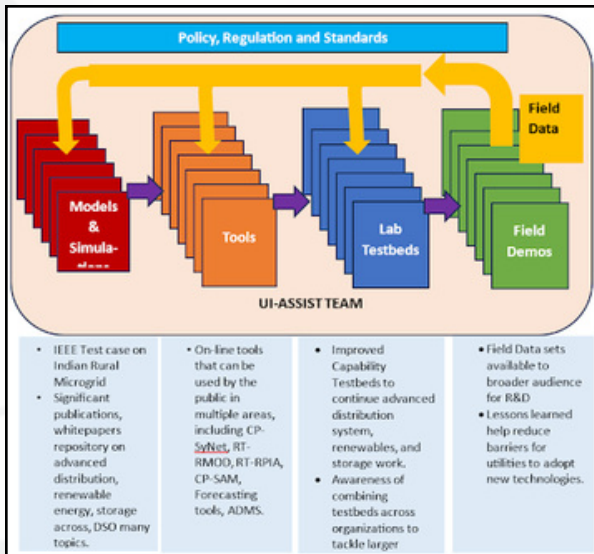

Figure 94: Future impacts of the UI-ASSIST project

In summary, the UI-ASSIST team consisted of 31 organizations, involved more than 160 researchers and 150 students, conducted 15 workshops, more than 60 webinars, made 100s of presentations, and published more than 400 research papers, articles and white papers. It provided unique perspectives, skills and knowledge that helped in

- Understanding the big picture for clean energy opportunities and challenges,
- National and international similarities and differences,
- Entire process from R&D to Field Demonstrations of smart distribution system concepts
- Interactions across multiple sectors of technical community
- Many new collaboration partnerships within and across two countries.

It is envisaged that the UI-ASSIST team, built across utilities, industry, research labs and academia from the two countries, will serve as technical leaders of today and tomorrow in clean energy and sustainable smart distribution systems development. The R&D outcomes and key learnings from the implementations in the UI-ASSIST project will enhance the awareness of all the stakeholders and pave the way for wider adoption of Smart Distribution System concepts by the utilities and system integrators.





## Joint Journals (India-US)

- [1] Satabdy Jena, Narayana Prasad Padhy and Josep M. Guerrero, "Cyber-Resilient Cooperative Control of DC Microgrid Clusters", *IEEE Systems Journal*, Volume: 16, Issue: 2, PP. 1996 - 2007, June 2022, DOI: 10.1109/JSYST.2021.3059445.
- [2] P. Paul, M. R. Bhatnagar, and J. Nebhen, "Pulse Jamming in Aperture-Averaged FSO Receiver over Exponentiated Weibull Fading Channel," in *IEEE Transactions on Wireless Communications*, Volume: 21, Issue: 6, PP. 4242-4254, June 2022, doi: 10.1109/TWC.2021.3128324
- [3] S. Som, R. Dutta, A. Gholami, A. Srivastava, S. Chakrabarti, S. R. Sahoo, "µPMU-Based Multiple Event Detection in a Microgrid Considering Bad Measurements", *Applied Energy Special Issue on the Microgrid*, November 2021
- [4] R. Panigrahi, S. K. Mishra, A. Joshi and K. Ngo, "Synthesis of DC-DC Converters from Voltage Conversion Ratio and Prescribed Requirements", *IEEE Transactions on Power Electronics*, Volume: 36, Issue: 12, PP. 13889-13902, December 2021, DOI: 10.1109/TPEL.2021.3085520.
- [5] S. Pannala, N. P. Padhy and P. Agarwal, "Effective power management scheme for PV-Battery-DG integrated standalone DC microgrid," in *IET Electric Power Applications*, Volume 14, Issue 12, PP.2322-2330, December 2020
- [6] P. Sanjeev, N. Patari, Anurag K Srivastava, and N. P. Padhy, "Effective Control and Management Scheme for Isolated and Grid Connected DC Microgrid," *IEEE Transactions on Industry Applications*, Volume 56, Issue 6, PP. 6767-6780, November-December 2020.
- [7] S. Ghosh, M. R. Bhatnagar, W. Saad, and B. K. Panigrahi, "Defending False Data Injection on State Estimation over Fading Wireless Channels," in *IEEE Transactions on Information Forensics and Security*, Volume: 16, PP. 1424 - 1439, October 2020 DOI:10.1109/TIFS.2020.3031378.

- [8] Ramanuja Panigrahi, Santanu K. Mishra, S. C. Srivastava, Anurag K. Srivastava, and Noel N. Schulz, "Grid Integration of Small-Scale Photovoltaic Systems in Secondary Distribution Network-A Review," *IEEE Transactions on Industry Applications*, Volume 56, Issue 3, PP. 3178 – 3195, May-June 2020.

---

## Joint Conference Papers (India-US)

- [1] S. Pannala, A. Khan, N. Schulz, A. Srivastava, A. Sharma and S.C. Srivastava, "Cooperative Framework For Mitigation of Voltage Limit Violations in a Rural Distribution System with Electric Vehicles Fleet," *IEEE NPSC Conference 2022*, December 17-19, 2022, PP 1-6.
- [2] S. Jena, P.S. Sarker, S. Pannala, N P Padhy and A Srivastava "Real Time Implementation and Co-Simulation of Cyber Physical DC Microgrid Clusters," *IEEE Power Electronics, Drives and Energy Systems (PEDES) 2022*, December 14-17, 2022, PP 1-6.
- [3] A. Sharma, S. Pannala, A. Mohapatra, A. Srivastava, A. Sharma, N. Schulz, S. Gibson and J. Hieb, "Real Time Adjustment to Mitigate the SPV Forecasting Errors with BESS and EV - An Utility Case Study" *IEEE PIICON Conference, 2022*, November 25-27, 2022, PP 1-5. (Accepted)
- [4] A. Narendra Babu, N. Yalla, S. Pannala, S. Haldar, and P. Agarwal "A Triple Voltage Boost Frontend Hybrid T-Type Converter," Accepted in *IEEE/AIAA ITEC+EATS conference 2022*, June 15-17, 2022, PP 1-6.
- [5] Shiv Kumar Singh, Ankush Sharma, Santanu Mishra, Suresh Chandra Srivastava, Deep Mukherjee, Anurag K. Srivastava, Noel Schulz," A Rural Microgrid Field Pilot in India Ensuring Reliable Electricity Supply and Social Upliftment" *IEEE Global Humanitarian Technology Conference (GHTC)*, Seattle, WA, USA, 19-23 October 2021.

- [6] Raja Dutta, Shreyasi Som, Saikat Chakrabarti, Ankush Sharma and rshid Anurag K Srivastava, "Event Detection and Localization in Active Distribution Networks using PMUs", IEEE PES General Meeting, July 2020
- [7] O. Ray, M. S. Rana, S. Mishra, K. Davies, and S. Sepasi, "Battery-swap Technology for e-Rickshaws: Challenges, Opportunity and Scope", accepted to National Power Systems Conference (NPSC) 2020.
- [8] Sanjeev Pannala, N P Padhy, A.K. Srivastava," Effective Power Management Scheme for Isolated DC Microgrid," IEEE International Conference on "Power Electronics, Smart Grid and Renewable Energy (PESGRE 2020), Jan 2-4, 2020, Cochin, Kerala, India
- [9] Rajarshi Dutta, Pratim Kundu, Anurag. K. Srivastava, "Dynamic State and Parameter Estimation of Distributed Generators using Constraint Recursive Least Square Algorithm and PMU Data", IEEE International conference on Power Electronics, Smart Grid and Renewable Energy (PESGRE 2020), Jan 2-4, 2020, Cochin, Kerala, India
- [10] S. Jena, N. Padhy, S.C. Srivastava and Noel N. Schulz, "A hybrid RC-droop control strategy for power sharing and voltage restoration in islanded DC microgrids," IEEE 8th International Conference on Power Systems, Dec. 2019, Jaipur, India.
- [11] S. Paul, N. P. Padhy, S. K. Mishra, A. K. Srivastava, "UUCA: Utility-User Cooperative Algorithm for Flexible Load Scheduling in Distribution System", International Conference on Power Systems, Jaipur, India, 2019
- [12] V. Patel, S. Ghosh, S. Chakrabarti, A. Sharma, and S. Pannala,"Neural Network Based Fault location in Power Distribution System" 2023 IEEE ISGT Asia, November 21-24, PP 1-5.(Accepted)
- [13] V. Patel, B. Mccornack, S. Pannala, A. Soni, A. Sharma, and N. Schulz, A. Srivastava, "Transnational Federated Testbed: Analyzing Impact of Network Parameters on T&D Co-Simulation" IEEE ETFG 2023, December 3-6, 2023, pp.1-6. (Accepted)
- [14] M. Kumar, P. K. Jha, J. Crawford Alasdair, S. Dandriyal and R. Maurya, "Comparative Analysis of Six Short-Term Load Forecasting Models for a Distribution Transformer," 2023 6th International Conference on Renewable Energy for Developing Countries (REDEC), Zouk Mosbeh, Lebanon, 2023, pp. 48-53, doi: 10.1109/REDEC58286.2023.10208192.

## Journals (India)

- [1] Vineeth Vijayan, A. Mohapatra, S. N. Singh and C. L. Dewangan, "An Efficient Modular Optimization Scheme for Unbalanced Active Distribution Networks with uncertain EV and PV Penetrations," in IEEE Transactions on Smart Grid, (Early Access), January 2023, doi: 10.1109/TSG.2023.3234551.
- [2] Tripti Gangwar, N. P. Padhy, and P. Jena, "Storage Allocation in Active Distribution Networks Considering Life Cycle and Uncertainty," IEEE Transactions on Industrial Informatics, Volume: 19, Issue: 1, PP. 339-350, January. 2023.
- [3] Satadby Jena and N P Padhy, "Reconfigurable and Privacy-Preserving Economical Operation for Interconnected DC Microgrid Clusters", IEEE Systems Journal, January 2023, doi: 10.1109/JSYST.2023.3236115.
- [4] S. Samal, S. R. Samantaray and N. K. Sharma "Data-mining Model based Enhanced Differential Relaying Scheme for Microgrids", IEEE Systems Journal (Accepted), December 2022.
- [5] N. Lokesh and Mahesh K. Mishra, "Design of a Decoupled Sliding Mode Control for Four-Leg Distribution Static Compensator," in IEEE Transactions on Power Delivery, Volume: 37, Issue: 6, PP. 5014-5024, December 2022.
- [6] Suresh Maganti and N. P. Padhy, "A Feedback-Based Flexible Compensation Strategy for a Weak-Grid-Tied Current-Controlled Converter Under Unbalanced and Harmonic Conditions," in IEEE Transactions on Industry Applications, Volume: 58, Issue: 6, PP. 7739-7753, November-December 2022, doi: 10.1109/TIA.2022.3195186.
- [7] Vineeth Vijayan, A. Mohapatra, S. N. Singh and A. Tiwari, "A Blended Approach to Improve Reliability and Efficiency of Active EDN via Dynamic Feeder Reconfiguration, Demand Response, and VVO," in IEEE Transactions on Automation Science and Engineering, 2022, doi: 10.1109/TASE.2022.3220523.
- [8] Subho Paul, N. Upadhyay and N. P. Padhy, "Residential Appliance Identification Using 1-D Convolutional Neural Network Based on Multiscale Sinusoidal Initializers," in IEEE Transactions on Industrial Informatics, Volume: 18, Issue: 11, PP. 7444-7453, November. 2022, doi: 10.1109/TII.2022.3168043.

- [9] Rashmi Prasad and N. P. Padhy, "Spatiotemporal Pattern Analysis of Nodal Inertia using Convex Combination of Walks of Generator Nodes in Varying Inertia System," in IEEE Transactions on Power Systems, (Early Access October 2022) doi: 10.1109/TPWRS.2022.3213419.
- [10] S. Paul and N. P. Padhy, "Real-Time Advanced Energy-Efficient Management of an Active Radial Distribution Network," in IEEE Systems Journal, Volume: 16, Issue: 3, PP. 3602-3612, September 2022, doi: 10.1109/JSYST.2021.3113038.
- [11] R. Verma and N. P. Padhy, "Optimal Power Flow Based DR in Active Distribution Network with Reactive Power Control," in IEEE Systems Journal, Volume: 16, Issue: 3, PP. 3522 - 3530, September 2022, doi: 10.1109/JSYST.2021.3106397
- [12] Rohan Madnani and M.K. Mishra, "A Visual Understanding of Electrical Transformations and Generalized abc to  $\alpha\beta$  and dq0 Transformation", International Journal of Circuit Theory and Applications, September 2022, <https://doi.org/10.1002/cta.3439>
- [13] Subho Paul and N. P. Padhy, "A New Real Time Energy Efficient Management of Radial Unbalance Distribution Networks Through Integration of Load Shedding and CVR," in IEEE Transactions on Power Delivery, Volume: 37, Issue: 4, PP. 2571-2586, August 2022, doi: 10.1109/TPWRD.2021.3112340
- [14] S. Maganti and N. P. Padhy, "Analysis and Design of PLL Less Current Control for Weak Grid-Tied LCL Type Voltage Source Converter," in IEEE Journal of Emerging and Selected Topics in Power Electronics, Volume: 10, Issue: 4, PP. 4026 - 4040, August 2022, doi: 10.1109/JESTPE.2021.3129804.
- [15] P. D. Achlerkar and B. K. Panigrahi, "Dynamic Harmonic Domain Modeling and Stability Augmented Design of Inverter Interface to Weak and Unbalanced Grid," in IEEE Transactions on Power Delivery, Volume: 37, Issue: 4, PP. 3097 - 3110, August 2022, doi: 10.1109/TPWRD.2021.3123370.
- [16] D. Pal and B. K. Panigrahi, "A Nonlinear Adaptive Stabilizing Control Strategy to Enhance Dynamic Stability of Weak Grid-Tied VSC System," in IEEE Transactions on Power Delivery, Volume: 37, Issue: 3, PP. 2182 - 2193, June 2022, doi: 10.1109/TPWRD.2021.3106682.
- [17] P. Paul and M. R. Bhatnagar, "Random Relay Jamming in Cooperative Free Space Optical Systems," in IEEE Systems Journal, Volume: 16, Issue: 2, PP. 2413 - 2424, June 2022, doi: 10.1109/JSYST.2021.3099019
- [18] Vineeth Vijayan, A. Mohapatra and S. N. Singh, "A Topology Assisted Optimal CVR Strategy for Unbalanced EDNs Having Spatio-Temporal Loads", in IEEE Transactions on Industry Applications, Volume. 58, Issue: 3, PP. 3313-3323, May-June 2022, doi: 10.1109/TIA.2022.3162188..
- [19] Abha Saxena, Nikhil Kumar Sharma, S R Samantaray, "An Enhanced Differential Protection Scheme for LVDC Microgrid", IEEE Journal of Emerging and Selected Topics in Power Electronics, Volume: 10, Issue: 2, PP. 2114-2125, April 2022, doi: 10.1109/JESTPE.2022.3144300 .
- [20] Hariharan R and Mahesh K. Mishra, "An Integrated Control of Enhanced-PLL and Synchronverter for Unbalanced Grid," IEEE Transactions on Industry Applications, Volume: 58, Issue. 2, PP. 2206-2216, March-April 2022, doi: 10.1109/TIA.2021.3139580.
- [21] Diptak Pal and Bijaya Ketan Panigrahi, "Small Signal Stability Analysis Oriented Design of Hybrid Anti-Islanding Protection Technique Based on Active Disturbance Injection", in IEEE Systems Journal, Volume: 16, Issue: 1, PP. 1448-1459, March 2022, DOI: 10.1109/JSYST.2021.3050468
- [22] Durga Malleswara Rao Korada, Mahesh Kumar Mishra, "Adaptive Power Management Algorithm for Multi-Source DC Microgrid System," International Journal of Emerging Electric Power Systems, March 2022, <https://doi.org/10.1515/ijeeps-2021-0400>
- [23] Nikhil Kumar Sharma, S. R. Samantaray and C N Bhende, "VMD enabled Current based Fast Fault Detection Scheme for DC Microgrid," IEEE Systems Journal, Volume: 16, Issue: 1, PP. 933-944, March 2022, DOI: 10.1109/JSYST.2021.3057334
- [24] A. Kumar, A. Mohapatra and S. N. Singh, "Phaselet-Based Limited-Time q-Axis DC Offset Voltage Injection for Detection of Islanding of DG and Fault in a Meshed Microgrid," IEEE Systems Journal, Volume: 16, Issue: 1, PP. 1379 - 1390, March 2022, DOI: 10.1109/JSYST.2021.3068397.
- [25] Y. Narendra Babu and N. P. Padhy, "Investigation of Damping Effect of PLL on Low-Frequency Harmonic Stability of Grid-Tied Inverter with  $\alpha\beta$  and dq Current Control Schemes," in IEEE Journal of Emerging and Selected Topics in Power Electronics, Volume: 10, Issue: 1, PP. 1046-1060, February 2022, doi: 10.1109/JESTPE.2021.3079463.

- [26] R. Dutta, S. J. Geetha, S. Chakrabarti and A. Sharma, "An L-1 Regularized Forecasting-Aided State Estimator for Active Distribution Networks," in IEEE Transactions on Smart Grid, Volume: 13, Issue: 1, PP. 191-201, January 2022, doi: 10.1109/TSG.2021.3115816.
- [27] P. D. Achlerkar and B. K. Panigrahi, "New Perspectives on Stability of Decoupled Double Synchronous Reference Frame PLL," in IEEE Transactions on Power Electronics, Volume: 37, Issue: 1, PP. 285-302, Jan. 2022, doi: 10.1109/TPEL.2021.3099162.
- [28] A. M. Jadhav and Abhijit R. Abhyankar, "Emergence of Distribution System Operator in the Indian Power Sector and Possible Way Ahead," Energy Policy, Elsevier, Volume 160, January 2022, <https://doi.org/10.1016/j.enpol.2021.112650>
- [29] P. Paul, S. Ghosh, and M. R. Bhatnagar, "Abating Jamming in Free Space Optical Systems—A Game-theoretic Solution," in IEEE Transactions on Communications, Volume: 69, Issue. 12, PP. 8375-8387, December 2021, doi: 10.1109/TCOMM.2021.3109941
- [30] Vineeth Vijayan, Abheejeet Mohapatra, S.N. Singh, "Demand Response with Volt/Var Optimization for Unbalanced Active Distribution Systems", Applied Energy, Volume 300, 2021, 117361, ISSN 0306-2619, <https://doi.org/10.1016/j.apenergy.2021.117361>.
- [31] V. Saxena, N. Kumar, B. Singh and B. K. Panigrahi, "A Voltage Support Control Strategy for Grid Integrated Solar PV System During Abnormal Grid Conditions Utilizing Interweaved GI," IEEE Transactions on Industrial Electronics, Volume: 68, Issue: 9, PP. 8149 - 8157, September 2021, doi: 10.1109/TIE.2020.3013771.
- [32] T. N. Gupta, B. Singh and S. B. Q. NAQVI, "Performance Evaluation of Single-Phase PV-BES Based Microgrid with Seamless Transition Capability," IEEE Transactions on Industrial Electronics, Volume: 68, Issue: 9, PP. 8321-8332, September 2021, doi: 10.1109/TIE.2020.3016256.
- [33] S. Paul and N. P. Padhy, "Real-Time Energy Management for Smart Homes," in IEEE Systems Journal, Volume: 15, Issue: 3, PP. 4177 - 4188, September 2021, doi: 10.1109/JSYST.2020.3016358.
- [34] Nikhil Kumar Sharma, S R Samantaray, "A Composite Magnitude-Phase Plane of Impedance Difference for Microgrid Protection using Synchrophasor Measurements", IEEE Systems Journal, Volume: 15, Issue: 3, PP. 4199 - 4209, September 2021, DOI: 10.1109/JSYST.2020.2999483
- [35] V. Narayanan, S. Kewat and B. Singh, "Control and Implementation of a Multifunctional Solar PV-BES-DEGS Based Microgrid," IEEE Transactions on Industrial Electronics, Volume: 68, Issue: 9, PP. 8241 - 8252, September 2021, doi: 10.1109/TIE.2020.3013740
- [36] Suman Rath, Diptak Pal, Parth Sarthi Sharma, and Bijaya Ketan Panigrahi, "A Cyber-Secure Distributed Control Architecture for Autonomous AC Microgrid", IEEE Systems Journal, Volume: 15, Issue: 3, PP. 3324 - 3335, September 2021, DOI: 10.1109/JSYST.2020.3020968
- [37] S. Paul, A. Sharma and N. P. Padhy, "Risk Constrained Energy Efficient Optimal Operation of a Converter Governed AC/DC Hybrid Distribution Network With Distributed Energy Resources and Volt-VAR Controlling Devices," in IEEE Transactions on Industry Applications, Volume: 57, Issue: 4, PP. 4263-4277, July-Aug. 2021, doi: 10.1109/TIA.2021.3081526.
- [38] R. Panigrahi, S. Mishra and A. Joshi, "Synthesis of an Optimum Converter Topology for a Specified Voltage Conversion Ratio", IEEE Transactions on Industry Applications, Volume: 57, Issue: 4, PP. 3923 - 3934, July-Aug. 2021 DOI: 10.1109/TIA.2021.3081401.
- [39] Diptak Pal and Bijaya Ketan Panigrahi, "On the Marginal Stability/Instability of Power Island following Unintentional Islanding: A Modal Analysis Based Approach", in IEEE Transactions on Circuits and Systems II: Express Briefs, Volume: 68, Issue: 7, PP. 2468 - 2472, July 2021, DOI: 10.1109/TCSII.2021.3050519
- [40] Rajarshi Dutta, Saikat Chakrabarti, and Ankush Sharma "Topology Tracking for Active Distribution Networks," IEEE Transactions on Power Systems, Volume: 36, Issue: 4, PP. 2855 - 2865, July 2021, DOI: 10.1109/TPWRS.2020.3045855

- [41] Vivek Narayanan, Seema Kewat and Bhim Singh, "Implementation of a Multi-Objective Control for Islanded Hybrid Microgrid," IEEE Transactions on Industry Applications, Volume: 57, Issue: 3, PP. 2702 – 2713, May-June 2021.
- [42] Nidhi Mishra, Shivam Kumar Yadav, Bhim Singh, P. Sanjeevikumar, Frede Blaabjerg, "Binary-Quintuple Progression Based Twelve Switch Twenty-Five Level Converter with Nearest Level Modulation Technique for Grid-Tied and Standalone Applications," in IEEE Transactions on Industry Applications, Volume: 57, Issue: 3, PP. 3214 - 3223, May-June 2021, DOI: 10.1109/TIA.2020.3041563
- [43] Shri Ram Vaishya, A. R. Abhyankar and Vaskar Sarkar "Marginal Loss Modeling based DCOPF and LMP Calculations for an Integrated AC and Multi-terminal HVDC System", IEEE Transactions on Power Systems, Volume: 36, Issue: 3, PP. 1867 - 1878, May 2021, DOI: 10.1109/TPWRS.2020.3024857
- [44] Nachiketa Deshmukh, Siva Prabhakar, and Sandeep Anand, "Power Loss Reduction in Buck Converter Based Active Power Decoupling Circuit," IEEE Transactions on Power Electronics, Volume 36, Issue 4, PP. 4316 – 4325, April 2021.
- [45] P. D. Achlerkar and B. K. Panigrahi, "Recursive Least Squares based Adaptive Parameter Estimation Scheme for Signal Transformation and Grid Synchronization", IEEE Journal of Emerging and Selected Topics in Power Electronics, Volume: 9, Issue: 2, PP.2427 - 2439, April 2021, DOI: 10.1109/JESTPE.2020.2970445
- [46] B. Singh, R. Sharma, and S. Kewat, "Robust Control Strategies for SyRG-PV and Wind Based Islanded Microgrid," IEEE Transactions on Industrial Electronics, Volume 68, Issue 4, PP. 3137 -3147, April 2021.
- [47] I. Chauhan, P. Paul, M. Bhatnagar, and J. Nebhen, "Performance of optical space shift keying under jamming," Applied Optics Volume: 60, Issue: 7, PP. 1856-1863, March 2021, <https://doi.org/10.1364/AO.414456>
- [48] Hariharan R and Mahesh K. Mishra, "Analysis and Design of Gradient Descent Based Pre-Synchronization Control for Synchronverter," IET Renewable Power Generation, Volume: 15, Issue: 2, PP. 297–312, February 2021.
- [49] V. Saxena, N. Kumar, B. Singh and B. K. Panigrahi, "A Rapid Circle Centre-Line Concept-Based MPPT Algorithm for Solar Photovoltaic Energy Conversion Systems," in IEEE Transactions on Circuits and Systems Volume: 68, Issue: 2, Feb. 2021, DOI: 10.1109/TCSI.2020.3038114. .
- [50] Pankaj D. Achlerkar, Vibhuti Nougain, B. K. Panigrahi, "Backstepping Technique based Customer-end Voltage Control Strategy of DC Distribution Network", IEEE Journal of Emerging and Selected Topics in Power Electronics, Volume: 9, Issue: 1, PP. 666 - 676, February 2021, DOI: 10.1109/JESTPE.2019.2959670
- [51] Vivek Narayanan, Seema Kewat, and Bhim Singh, "Real-Time Implementation of CLMS Algorithm in 3P4W Solar PV-BES Based Microgrid System," IEEE Transactions on Industry Applications, Volume 57, Issue 1, PP.795-804, January/February 2021.
- [52] Abhishek Ranjan, Seema Kewat, and Bhim Singh, "DSOGI-PLL With In-Loop Filter Based Solar Grid Interfaced System for Alleviating Power Quality Problems," IEEE Transactions on Industry Applications, PP.730 – 740, Volume 57, Issue 1, January/February 2021.
- [53] Tanmay Tewari, Abheejeet Mohapatra, and Sandeep Anand, "Coordinated Control of OLTC and Energy Storage for Voltage Regulation in Distribution Network with High PV Penetration", IEEE Transactions on Sustainable Energy, Volume: 12, Issue: 1, PP. 262 - 272, January 2021. DOI: 10.1109/TSTE.2020.2991017
- [54] V. Narayanan, S. Kewat, B. Singh, and P. Jayaprakash, "A New Two Leg Converter Based Multifunctional TPFW Grid Tied Single Stage Solar PV System," Journal of the Institution of Engineers (India): Series B., 102, 415–425, January 2021
- [55] S. Karmakar, N. Mishra, S.K. Yadav, and B. Singh, "Fundamental Switched MW-Size Multilevel Converter for Large-Scale Solar PV Plant," IET Renewable Power Generation, Volume: 14, Issue: 18, PP. 3853-3863, December 2020, p. 3853 – 3863.
- [56] S. Pannala, N. P. Padhy and P. Agarwal, "Effective power management scheme for PV-Battery-DG integrated standalone DC microgrid," in IET Electric Power Applications, Volume 14, Issue 12, PP.2322-2330, December 2020; Doi: <https://doi.org/10.1049/iet-epa.2020.0140>

- [57] M. V. Gururaj and N. P. Padhy, "An Improvized Coordinated Voltage Control Scheme for Better Utilization of Regulating Devices During Various Operating Conditions of a Distribution System," in *IEEE Systems Journal* Volume: 14, Issue: 4, PP. 4891-4900, December. 2020, doi: 10.1109/JSYST.2019.2959407.
- [58] P. Sanjeev, N. Patari, Anurag K. Srivastava, and N. P. Padhy, "Effective Control and Management Scheme for Isolated and Grid Connected DC Microgrid," *IEEE Transactions on Industry Applications*, Volume 56, Issue 6, PP. 6767-6780, November-December 2020.
- [59] S. B. Q. Naqvi, S. Kumar and B. Singh, "Three-Phase Four-Wire PV System for Grid Interconnection at Weak Grid Conditions," *IEEE Transactions on Industry Applications*, Volume. 56, Issue: 6, PP. 7077-7087, Nov.-Dec. 2020, doi: 10.1109/TIA.2020.3020931.
- [60] Deepu Vijay M, B. Singh and G. Bhuvaneswari, "Grid-Tied Battery Integrated Wind Energy Generation System with an Ability to Operate Under Adverse Grid Conditions," *IEEE Transactions on Industry Applications*, Volume: 56, Issue. 6, PP. 6882-6891, Nov.-Dec. 2020, doi: 10.1109/TIA.2020.3024156.
- [61] F. Chishti, S. Murshid and B. Singh, "PCC Voltage Quality Restoration Strategy of an Isolated Microgrid Based on Adjustable Step Adaptive Control," *IEEE Transactions on Industry Applications*, Volume: 56, Issue: 6, PP. 6206-6215, Nov.-Dec. 2020, doi: 10.1109/TIA.2020.3018430.
- [62] F. Chishti, S. Murshid and B. Singh, "Natural Genetics Adapted Control for an Autonomous Wind-Battery Based Microgrid," *IEEE Transactions on Industry Applications*, Volume: 56, Issue: 6, PP. 7156-7165, Nov.-Dec. 2020, doi: 10.1109/TIA.2020.3024350.
- [63] Seema Kewat and B. Singh, "Grid Synchronization of WEC-PV-BES Based Distributed Generation System using Robust Control Strategy," *IEEE Transactions on Industry Applications*, Volume: 56, Issue: 6, PP. 7088-7098, November-December 2020
- [64] K. Murari and N. P. Padhy, "Graph-Theoretic-Based Approach for Solving Load Flow Problem of AC-DC Radial Distribution Network with Distributed Generations," in *IET Generation, Transmission & Distribution*, Volume: 14, Issue: 22, PP. 5327-5346, November 2020, doi: 10.1049/iet-gtd.2019.1416.
- [65] Susmita Kar and Subhransu Ranjan Samantaray, "Impact of Microgrid Operation on the Performance of Overcurrent Relay Coordination and Assessment of Differential Relay Coordination," in *Electric Power Components and Systems* Volume: 48, Issue: 9-10, PP. 1049-1062, October 2020, doi.org/10.1080/15325008.2020.1825550.
- [66] D. Pal and B. K. Panigrahi, "Analysis and Mitigation of the Impact of Ancillary Services on Anti-Islanding Protection of Distributed Generators," *IEEE Transactions on Sustainable Energy*, Volume 11, Issue 4, PP 2950 – 2961, October 2020.
- [67] Sunaina Singh, Seema Kewat, Bhim Singh, B.K. Panigrahi, "Enhanced Momentum LMS Based Control Technique for Grid-tied Solar System" *IET Power Electronics*, Volume 13, Issue 13, PP. 2767-2774, October 2020.
- [68] Deepu Vijay M, G. Bhuvaneswari and B. Singh, "A Reliable Microgrid Comprising Solar PV-WEGS and Battery with Seamless Power Transfer Capability," *IEEE Transactions on Industrial Electronics*, Volume: 68, Issue: 10, PP. 9665 - 9674, October 2021, doi: 10.1109/TIE.2020.3026284.
- [69] Sambasivaiah Puchalapalli, S. K. Tiwari, B. Singh, and P. K. Goel, "A Microgrid Based on Wind-Driven DFIG, DG, and Solar PV Array for Optimal Fuel Consumption," *IEEE Trans. Ind. Appl.*, Volume: 56, Issue: 5, PP. 4689-4699, Sept.-Oct. 2020. [DOI: 10.1109/TIA.2020.2999563].
- [70] Sambasivaiah Puchalapalli, B. Singh, S. K. Tiwari, and P. K. Goel, "Design and Analysis of Grid-Interactive DFIG Based WECS for Regulated Power Flow," *IEEE Trans. Ind. Appl.*, Volume: 56, Issue: 5, PP. 5396-5407, September/ October 2020. [DOI: 10.1109/TIA.2020.3011059].
- [71] Abhishek Ranjan, Seema Kewat, and Bhim Singh, "Reweighted L1 Norm Penalized LMS Fourth Algorithm of Solar Grid Interfaced System for Alleviating Power Quality Problems", *IEEE Transactions on Industry Applications*, Volume 56, Issue 5, PP. 5352–5362, September/ October 2020.
- [72] Pankaj D. Achlerkar, and Bijaya Ketan Panigrahi, "Robust Backstepping Output Voltage Controller for Standalone Voltage-Sourced Converters", *IET Renewable Power Generation*, Volume 14, Issue 12, PP. 2211-2220, September 2020.
- [73] Aastha Kapoor and Ankush Sharma, "Optimal Charge/Discharge Scheduling of Battery Storage Interconnected With Residential PV System", *IEEE Systems Journal*, Volume 14, Issue 3, PP. 3825 – 3835, September 2020.

- [74] V. Nougain and B. K. Panigrahi, "An Integrated Power Management Strategy of Grid-Tied DC Microgrid including Distributed energy Resources", IEEE Transactions on Industrial Informatics, Volume: 16, Issue: 8, PP. 5180–5190, August 2020.
- [75] Shivam Kumar Yadav, Nidhi Mishra, Bhim Singh, P. Sanjeevikumar, Frede Blaabjerg, and Massimo Mitolo, "Multi-objective Optimization Based Drift-Free MPPT Technique for Single PV Array Fed Grid-Connected Multilevel Converter," in IEEE Transactions on Industry Application, July 2020.
- [76] S. Karmakar, N. Mishra and B. Singh, "FFS modulated VSC with different phase-shifted 12-pulse configured transformers for grid integrated large-scale solar PV plant," IET Renewable Power Generation, Volume: 14, Issue: 10, PP. 1746-1754, July 2020, doi: 10.1049/iet-rpg.2019.0970.
- [77] R. Prasad and N. P. Padhy, "Synergistic Frequency Regulation Control Mechanism for DFIG Wind Turbines With Optimal Pitch Dynamics," in IEEE Transactions on Power Systems, Volume: 35, Issue: 4, PP. 3181-3191, July 2020, doi: 10.1109/TPWRS.2020.2967468.
- [78] Rakesh Kumar Panda, Abheejeet Mohapatra and Suresh Chandra Srivastava, "Online Estimation of System Inertia in a Power Network utilizing Synchrophasor Measurements", IEEE Transactions on Power Systems, Volume: 35, Issue: 4, PP. 3122 - 3132, July 2020, DOI 10.1109/TPWRS.2019.2958603.
- [79] S. Paul and N. P. Padhy, "Real-Time Bi-level Energy Management of Smart Residential Apartment Building," in IEEE Transactions on Industrial Informatics, Volume: 16, Issue: 6, PP. 3708-3720, June 2020, doi: 10.1109/TII.2019.2941739
- [80] Sambasivaiah Puchalapalli and B. Singh, "A Novel Control Scheme for Wind Turbine Driven DFIG Interfaced to Utility Grid," IEEE Trans. Ind. Appl., vol. 56, no. 3, pp. 2925-2937, May-June 2020. [DOI: 10.1109/TIA.2020.2969400].
- [81] R. Sharma, S. Kewat and B. Singh, "SyRG-PV-BES-Based Standalone Microgrid Using Approximate Multipliers Based Adaptive Control Algorithm," IEEE Transactions on Industry Applications, Volume: 56, Issue: 3, PP. 2913-2924, May-June 2020, doi: 10.1109/TIA.2020.2969393.
- [82] M. V. Gururaj and N. P. Padhy, "PHIL Experimentation on Fault Ride Through Behavior of Doubly Fed Induction Generator-Based Wind System in the Presence of Fault Current Limiter," in IEEE Transactions on Industry Applications, Volume: 56, Issue: 3, PP. 2988-3005, May-June 2020, doi: 10.1109/TIA.2020.2969636.
- [83] Ramanuja Panigrahi, Santanu K. Mishra, S. C. Srivastava, Anurag K. Srivastava, and Noel N. Schulz, "Grid Integration of Small-Scale Photovoltaic Systems in Secondary Distribution Network-A Review", IEEE Transactions on Industry Applications, Volume 56, Issue 3, PP. 3178–3195, May-June 2020.
- [84] V. Narayanan, S. Kewat and B. Singh, "Solar PV-BES Based Microgrid System with Multifunctional VSC" IEEE Transactions on Industry Applications, Volume 56, Issue 3, PP. 2957 – 2967, May-June 2020.
- [85] Seema and Bhim Singh, "Improved Reweighted Zero-Attracting Quaternion-Valued LMS Algorithm for Islanded Distributed Generation System at IM Load," IEEE Transactions on Industrial Electronics, Volume: 67, Issue: 5, PP. 3705-3716, May 2020.
- [86] K. Murari and N. P. Padhy, "Graph-Theoretic Based Approach for The Load-Flow Solution of Three-Phase Distribution Network in The Presence of Distributed Generations," in IET Generation, Transmission & Distribution, Volume: 14, Issue: 9, PP. 1627-1640, May 2020, doi: 10.1049/iet-gtd.2019.1176.
- [87] V. Narayanan, S. Kewat and B. Singh, "MVSS-LMS control for a three-phase standalone solar PV-BES-DG based microgrid", International Transactions on Electrical Energy Systems (Early Access) April 2020. DOI:10.1002/2050-7038.12412
- [88] N. Pruthvi Chaithanya and Mahesh K. Mishra, "Droop characteristics-based damping and inertia emulation of DC link in a hybrid microgrid", IET Renewable Power Generation, Volume: 14, Issue: 6, PP. 1044-1052, April 2020.
- [89] Sunaina Singh, Seema Kewat, Bhim Singh, B.K. Panigrahi, "BD-VSS Individual Weighting Factor Sign Based Adaptive Filter Control for Power Quality Improvement in Weak Distribution Grid" published in IET Generation, Transmission & Distribution, Volume: 14, Issue: 8, PP. 1450 – 1457, April 2020

- [90] Anju Meghwani, Ramakrishna Gokaraju, Suresh Chandra Srivastava, and Saikat Chakrabarti "Local Measurements-Based Backup Protection for DC Microgrids Using Sequential Analyzing Technique" IEEE Systems Journal, Volume: 14 , Issue: 1, PP. 1159-1170 , March 2020.
- [91] Sonam Acharya, Olive Ray, and Santanu Mishra, "Powering milliWatts to MegaWatts", IEEE Consumer Electronics Magazine, Volume: 9, Issue: 2, PP. 70-75, March 2020.
- P. Paul, M. R. Bhatnagar, and A. Jaiswal," Jamming in Free Space Optical Systems: Mitigation and Performance Evaluation", IEEE Transactions on Communications, Volume: 68, Issue: 3, PP. 1631–1647, March 2020.
- [92] M. V. Gururaj and N. P. Padhy, "A Cost-Effective Single Architecture to Operate DC Microgrid Interfaced DFIG Wind System During Grid-Connected, Fault, and Isolated Conditions," in IEEE Transactions on Industrial Informatics, Volume: 16, Issue: 2, PP. 922-934, Feb. 2020, doi: 10.1109/TII.2019.2926672.
- [93] Rakesh Kumar Panda, Abheejeet Mohapatra and Suresh Chandra Srivastava, "Enhancing Inertia of Solar Photovoltaic based Microgrid through Notch Filter based PLL in SRF Control", IET Proc. Generation Transmission and Distribution, Vol. 14 Issue 3, PP. 379-388, February 2020.
- [94] J. Hussain and Mahesh K. Mishra, "An Efficient Wind Speed Computation Method Using Sliding Mode Observers in Wind Energy Conversion System Control Applications," IEEE Transactions on Industry Applications, Volume: 56, Issue:1, PP. 730-739, Jan.-Feb. 2020.
- [95] P. Paul, M. R. Bhatnagar, and A. Jaiswal, "Alleviation of Jamming in Free Space Optical Communication over Gamma-Gamma Channel with Pointing Errors", IEEE Photonics Journal, Volume: 11, Issue: 5, October 2019.
- [96] S. Ghosh, M. R. Bhatnagar, and B. K. Panigrahi, "Defense Against Unknown Broadband Jammer for Time-Critical Operation in Smart Grid", IET Communications, Volume: 13, Issue: 15, PP. 2261-2272, September 2019.
- [97] S. Singh, S. Kewat, B. Singh, B. K. Panigrahi and M. K. Kushwaha, "Seamless Control of Solar PV Grid Interfaced System with Islanding Operation," IEEE Power and Energy Technology Systems Journal, Volume 6, Issue 3, PP. 162-171, September 2019.
- [98] Seema and Bhim Singh, "Modified Amplitude Adaptive Control Algorithm for Power Quality Improvement in Multiple Distributed Generation System," IET Power Electronics, Volume 12, Issue 9, PP. 2321-2329, August 2019.
- [99] Srikanth Kotra and Mahesh K. Mishra, "Design and Stability Analysis of DC Microgrid with Hybrid Energy Storage System", IEEE Transactions on Sustainable Energy, Volume: 10, Issue: 3 , PP.1603 - 1612 , July 2019.
- [100] K. Murari, N. P. Padhy, A. K. Pradhan and F. Li, "Investigating the Impact of Protection System Reinforcement Cost on the Consumers Associated with Renewable Integrated Distribution Network," in IET Generation, Transmission & Distribution, Volume: 13, Issue: 9, PP. 1572-1588, July 2019, doi: 10.1049/iet-gtd.2018.5710.
- [101] Aasim, S. N. Singh and Abheejeet Mohapatra, "Repeated Wavelet Transform based ARIMA Model for Very Short-Term Wind Speed Forecasting ", Renewable Energy, Volume 136, PP 758 -768, June 2019.
- [102] M. Pradhan and Mahesh K. Mishra, "Dual P-Q Theory based Energy Optimized Dynamic Voltage Restorer for Power Quality Improvement in Distribution System", IEEE Transactions on Industrial Electronics, Volume 66, Issue 4, PP. 2946 – 2955, April 2019.
- [103] Ram Shankar Yallamilli and Mahesh K. Mishra, "Instantaneous Symmetrical Component Theory Based Parallel Grid Side Converter Control Strategy for Microgrid Power Management" IEEE Transactions on Sustainable Energy, Volume: 10, Issue: 2, PP. 682 - 692, April 2019.
- [104] K. Murari and N. P. Padhy, "A Network-Topology Based Approach for the Load Flow Solution of AC-DC Distribution System with Distributed Generations", IEEE Transactions on Industrial Informatics, Volume: 15, Issue: 3, PP. 1508-1520, March 2019.
- [106] S. Paul and N. P. Padhy, "Resilient Scheduling Portfolio of Residential Devices and Plug-in Electric Vehicle by Minimizing Conditional Value at Risk", IEEE Transactions on Industrial Informatics, Volume: 15, Issue: 3, PP. 1566 – 1578, March 2019.
- [107] Yun Ai, Aashish Mathur, Michael Cheffena, Manav R. Bhatnagar, "Physical Layer Security of Hybrid Satellite-FSO Cooperative Systems", IEEE Photonics Journal, Volume: 11, Issue: 1, February 2019.



- [108] A. S. Bedi, P. V. Aditya Prasad, M. W. Ahmad, S. Shinde, K. Rajawat, and S. Anand, "Online Algorithms for Storage Utilization under Real-Time Pricing in Smart Grid" , International Journal of Electrical Power and Energy Systems (Elsevier) Volume 101, Pages 50-59, October 2018.
- [109] Anju Meghwani, Suresh C. Srivastava, and Saikat Chakrabarti, "Local Measurement-based Technique for Estimating Fault Location in Multi-Source DC Microgrids", IET Generation, Transmission & Distribution, Volume 12, Issue 13, PP.3305–3313, July 2018.
- [110] J. G. Sreenath, S. Chakrabarti, and K. Rajawat, "Hierarchical Parallel Dynamic Estimator of States for Interconnected Power System", IET Generation, Transmission, and Distribution, Volume 12, Issue 10, PP. 2299 – 2306, May 2018.
- [7] K S Vinay, Y Hote and N P Padhy, "Simplified Modelling and Control of Voltage Source Converter Integrated to Renewable Energy Resources", Accepted for IEEE GLOBCONHT 2023, at The Maldives National University, 11-12, March 2023
- [8] Kamakshi P. Swain, A. Tiwari, Ankush Sharma, Saikat Chakrabarti, and Amey Karkare. "Comprehensive Demonstration of Man-in-the-Middle Attack in PDC and PMU Network." In 2022 22nd National Power Systems Conference (NPSC), pp. 213-217. IEEE, 2022.
- [9] S. Samal, S. R. Samantaray and N. K. Sharma, "An Improved Differential Current-Based Fault Detection Scheme for Microgrids", IEEE National Power System Conference (NPSC), 17-19 December 2022.

---

## Conference Papers (India)

- [1] Narendra Babu Y and N P Padhy, " An approach to Improve Harmonic Attenuation and Stability Performance in Multi-Parallel Inverter System", IEEE Trans. Power Delivery, early access, 2023.
- [2] Satabdy Jena and N P Padhy, "Cyber Secure Global Energy Equalisation in DC Microgrid Clusters under Data Manipulation Attacks", IEEE Trans. Ind. Applications, early access, 2023.
- [3] Satabdy Jena, N P Padhy and J M Guerrero, "Multi Layered Coordinated Countermeasures for DC Microgrid Clusters under Man in the Middle Attack", IEEE Trans. Ind. Applications, early access, 2023.
- [4] Praveer Kumar Jha, Falti Teotia, A K Saxena "Cybersecurity in the Indian Electricity Distribution System: A Review", 5th International Conference on Energy, Power and Environment (ICEPE) June 15-17, 2023, NIT Meghalaya (accepted)
- [5] Arijeet Roy; Rajbala Purnima Priya; Ankush Sharma "Comparative Study of False Data Injection Attack Detection Techniques in AC Smart Island", 2023 IEEE IAS Global Conference on Emerging Technologies (GlobConET), 9-21 May 2023, London, United Kingdom. Doi: 10.1109/GlobConET56651.2023.10150093
- [6] Ram Krishan, Mukesh Kumar, "Impact of Battery Energy Storage System on Distribution Transformer Insulation Life", 15th IEEE Green Technologies Conference (GreenTech) April 19-21, 2023 at Denver, Colorado.
- [10] Apurti Jain, Narayana Prasad Padhy and Mukesh kumar Pathak, "Modified Deadband Droop-Inspired Control of Batteries for Integration of VSG providing Ancillary Services to AC System", 2022, 10th IEEE Power Electronics, Drives and Energy Systems (PEDES) Conference, 14-17 December, Jaipur, India.
- [11] Apurti Jain, Mukesh kumar Pathak and Narayana Prasad Padhy, "Virtual Synchronous Generator with Fictitious Damper Winding for Compensatory Damping in Renewable Sources Integrated System", 2022, 10th IEEE Power Electronics, Drives and Energy Systems (PEDES) Conference, 14-17 December, Jaipur, India.
- [12] Subho Paul and Narayana Prasad Padhy, " Multi-Objective Energy Management of Active Distribution Network Using Multi-Cuts Tighter Outer Approximation," 2022, 10th IEEE Power Electronics, Drives and Energy Systems (PEDES) Conference, 14-17 December, Jaipur, India.
- [13] T. Gangwar, N. P. Padhy, and P. Jena, "Planning and Dispatch of Battery Energy Storage in Microgrid for Cycle-life Improvement", 2022, 10th IEEE Power Electronics, Drives and Energy Systems (PEDES) Conference, 14-17 December, Jaipur, India.
- [14] Satabdy Jena, Partha S Sarker, Sanjeev Pannala, N P Padhy and A Srivastava, "Real Time Modeling, Co-Simulation and Cyber-Physical Analysis for DC Microgrid Clusters", 2022, 10th IEEE Power Electronics, Drives and Energy Systems (PEDES) Conference, 14-17 December, Jaipur, India.

- [15] Narendra Babu .Y and N. Prasad Padhy, "A Method to Overcome Harmonic Instability in Grid-Tied Inverters Employing Active Damping", 2022, 10th IEEE Power Electronics, Drives and Energy Systems (PEDES) Conference, 14-17 December, Jaipur, India.
- [16] R. Basu and Mahesh K. Mishra, "Experimental Design and Development of a DFIG Wind Emulator Setup", 2022, 10th IEEE Power Electronics, Drives and Energy Systems (PEDES) Conference, 14-17 December, Jaipur, India.
- [17] Leelayathi E, Rohan Madnani and Mahesh K. Mishra, "Maximum Power Point Tracking of Single-Phase Grid-Connected PV based DC Microgrid System using Modified BBO Algorithm with PR Controller," 10th Power India International Conference (PIICON), 25-27 November 2022.
- [18] Satabdy Jena, N P Padhy and Anurag Srivastava, "Resilient Economical Operation of DC Microgrid Clusters with Heterogeneous Sources", 10th Power India International Conference (PIICON), 25-27 November 2022.
- [19] V. S. Patel, A. Kapoor, A. Sharma and S. Chakrabarti, "Locating Faulty Section in Tie-line Using Classification Based Methods," 2022 IEEE PES Innovative Smart Grid Technologies - Asia (ISGT Asia), Singapore, Singapore, 01-05 November 2022 .
- [20] Satabdy Jena and N P Padhy, "Resilient Operation of BESS in a Cooperative DC Microgrid under Data Manipulation Attacks", IEEE GLOBCONPT 2022, IHC New Delhi, 23-25, September 2022.
- [21] Narendra Babu .Y and N. Prasad Padhy, "Analysis on Critical Oscillations in Multi-parallel Inverter System with WAC Control," 2022 IEEE IAS Global Conference on Emerging Technologies (GlobConET), 20-22, May 2022.
- [22] Apurti Jain, Mukesh Kumar Pathak and Narayana Prasad Padhy, "Enhanced Frequency Control of AC Microgrid by Adaptable Virtual Inertia and Center-of-Gravity Approach", IEEE IAS Global Conference on Emerging Technologies (GlobConET 2022), 20-22 May 2022.
- [23] Y. Narendra Babu and N. P. Padhy, "Effect of Voltage Feedforward Loop on the Stability of Single and Multi-Parallel Inverter System," 2022 Second International Conference on Power, Control and Computing Technologies (ICPC2T) at Raipur, India, 1- 3, March 2022.
- [24] Tony Thomas and Mahesh K. Mishra, "A Robust Control Strategy for Power Management of an Islanded DC Microgrid," 2022 Second International Conference on Power, Control and Computing Technologies (ICPC2T), 1-3 March 2022.
- [25] Jorge I.D. Cisneros-Saldana, Smrutirekha Samal, Hemkesh Singh, Miroslav Begovic, S. R. Samantaray, "Microgrid Protection with Penetration of DERs - A Comprehensive Review," Presented in Texas Power and Energy Conference (TPEC)-2022, 28 February- 1 March 2022, Texas, USA
- [26] A. Panda and Mahesh K. Mishra, "Power Management of Hybrid Storage using Rule Based Adaptive Filtering in Electric Vehicle," 2022 IEEE International Conference on Power Electronics, Smart Grid, and Renewable Energy (PESGRE), 2-5 January 2022
- [27] T. Gangwar, N. P. Padhy, and P. Jena, "Management of energy storage dispatch in unbalanced distribution networks using OpenDSS", Presented in IEEE International Conference on Power Electronics, Smart Grid and Renewable Energy (PESGRE-2022), at Trivandrum, Kerala, India, 2-5 January 2022.
- [28] Apurti Jain, Mukesh Kumar Pathak and Narayana Prasad Padhy, "Quantification of Inertia Contribution from Non-Conventional Sources in AC Microgrids," Presented in IEEE International Conference on Power Electronics, Smart Grid and Renewable Energy (PESGRE-2022), at Trivandrum, Kerala, India, 2-5 January 2022.
- [29] V. Narayanan and B. Singh, "Dual Mode Operation of a Switched Reluctance Generator Based Wind Energy Conversion System and a Battery Integrated MG under Abnormal Utility Grid Conditions," Presented in IEEE International Conference on Power Electronics, Smart Grid and Renewable Energy (PESGRE-2022), at Trivandrum, Kerala, India, 2-5 January 2022.
- [30] Abhisek Panda, Mahesh K. Mishra, "Power Management of Hybrid Storage using Rule-Based Adaptive Filtering in Electric Vehicle" Presented in IEEE International Conference on Power Electronics, Smart Grid and Renewable Energy (PESGRE-2022), at Trivandrum, Kerala, India, 2-5 January 2022.

- [31] Hariharan R and Mahesh K. Mishra, "An Improved Synchronverter Control for DERs Under Grid Voltage Variations," 2021 IEEE International Conference on Smart Technologies for Power, Energy and Control (STPEC), Bilaspur, India, 19-22 Dec. 2021.
- [32] Hariharan R and Mahesh K. Mishra, "Analysis of Synchronverter Control with Virtual Impedance During Grid Voltage Variations," 2021 IEEE International Conference on Smart Technologies for Power, Energy and Control (STPEC), Bilaspur, India, 19-22 December 2021.
- [33] V. Narayanan and B. Singh, "A Switched Reluctance Generator Based WEGS and a Bidirectional DC-DC Converter Interfaced BES Microgrid with Uninterrupted Power," Presented in IEEE International Conference on Smart Technologies for Power, Energy and Control (STPEC), Bilaspur, India, 19-22 December 2021.
- [34] V. Narayanan and B. Singh, "Seamless Mode Control of Microgrid for Optimal Coordination of Conventional and Renewable Energy Resources," Presented in IEEE 6th International Conference on Computing, Communication and Automation (ICCCA-2021), 17-19 December 2021.
- [35] Abha Saxena, Nikhil Sharma, S R Samantaray, "An Intelligent Differential Protection Scheme for DC Microgrid", IEEE 9th International Conference on Power Systems (ICPS 2021), IIT Kharagpur India, 16-18 December 2021.
- [36] Rajarshi Basu, Mahesh K. Mishra, " Multiport AC-DC-AC Interfacing Converter for Microgrid Applications ", IEEE 9th International Conference on Power Systems (ICPS 2021), IIT Kharagpur India, 16-18 December 2021.
- [37] A. M. Jadhav, Shri Ram Vaishya and A. R. Abhyankar, "Envisioning Low-carbon Indian Power Grid Using Demand-side Flexibility," 9th International Conference on Power Systems (ICPS), IIT Kharagpur India, 16-18 December 2021.
- [38] Shaziya Rasheed, A. R. Abhyankar, "Cost Effective Operational Planning of a Retail Market with Distributed Generations," 9th International Conference on Power Systems (ICPS), IIT Kharagpur India, 16-18 December 2021.
- [39] Megha Gupta and A. R. Abhyankar "Day-ahead Energy Market Framework Utilizing Transmission-Distribution Coordination," 9th International Conference on Power Systems (ICPS), IIT Kharagpur India, 16-18 December 2021.
- [40] Suman Biswal and S R Samantaray, "A User Defined Characteristics Based Optimal Coordination of Directional Overcurrent Relay for Microgrids", NPEC 2021, IIT Bhubaneswar, 15-17 December 2021.
- [41] V. Narayanan and B. Singh, "Performance of a Multifunctional Battery Integrated Solar PV Based Microgrid under Abnormal Grid Conditions with Seamless Mode Transfer Capability," Presented in IEEE Uttar Pradesh Section International Conference on Electrical, Electronics, and Computer Engineering (UPCON 2021), at venue Tula's Institute, Dhoolkot, Dehradun, Uttarakhand, 11-13 November , 2021.
- [42] Shiv kumar Singh, Ankush Sharma, Santanu Mishra, Suresh Chandra Srivastava, Deep Mukherjee, Anurag K. Srivastava, Noel Schulz," A Rural Microgrid Field Pilot in India Ensuring Reliable Electricity Supply and Social Upliftment " 2IEEE Global Humanitarian Technology Conference (GHTC), Seattle, WA, USA , 19-23 October, 2021.
- [43] V. Narayanan and B. Singh, "Variable Step Size Modified Clipped Least Mean Square Adaptive Control for Power Quality Improvement for a Solar PV-BS Based Microgrid with Seamless Mode Transfer Capability," IEEE Energy Conversion Congress and Exposition (ECCE), 10-14 October, 2021.
- [44] V. Narayanan and B. Singh, "Improved Power Quality Multifunctional Solar PV- Battery Based Microgrid Interfaced to Utility Grid/Diesel Generator Set for Uninterrupted Power," 2021 IEEE 4th International Conference on Computing, Power and Communication Technologies (GUCON), Kuala Lumpur, Malaysia, 24-26 September, 2021.
- [45] M. V. Gururaj, R. Prasad and N. P. Padhy, "Real Time Simulation Study Upon the Impact of DFIG Interconnected DC Microgrid on the Distribution System," 2021 IEEE 4th International Conference on Computing, Power and Communication Technologies (GUCON), Kuala Lumpur, Malaysia, 24-26 September, 2021.
- [46] S. Paul, R. Prasad and N. P. Padhy, "A Sequential MILP Strategy for Energy Efficient Management of Unbalance Distribution Network," 2021 IEEE Power & Energy Society General Meeting (PESGM), Washington, DC, USA, 26-29, July 2021

- [47] Mukesh Kumar, Ram Krishan, “Non-Linear Auto-Regressive Modelling based Day-ahead BESS Dispatch Strategy for Distribution Transformer Overload Management,” 3rd International Conference on Electrical, Communication and Computer Engineering (ICECCE) 12-13 June 2021, Kuala Lumpur, Malaysia
- [48] S. Singh, Seema, B. Singh and B. K. Panigrahi, “Robust Control Technique of Grid Synchronization of SPV based BES System for Power Quality Improvement,” 2020 3rd International Conference on Energy, Power and Environment: Towards Clean Energy Technologies, 5-7 March 2021.
- [49] S. Singh, S. Kewat, B. Singh and B. K. Panigrahi, “ALMS Control Approach for Solar PV Grid Integrated Power Conversion System,” International Conference on Sustainable Energy and Future Electric transportation (SEFET-2021), 21-23 January, 2021.
- [50] S. Singh, S. Kewat, B. Singh and B. K. Panigrahi, “Grid Synchronization of SPV-BES DG System using Seamless Control with Power Quality Improvement,” Accepted in International Conference on Nascent Technologies in Engineering (ICNTE 2021), 15-16 January, 2021.
- [51] ShreevaPattnaik and Olive Ray, “Analysis of Multi-Cell Li-ion configurations with dissimilar SoC for Battery Swap Application,” 1st International Conference on Power Electronics and Energy (ICPEE), Bhubaneswar, India, 2-3 January 2021.
- [52] Pragya Nand Singh, Sanchari Hajari, Olive Ray, and S. R. Samantaray, “Development of Controller HIL Test-bed for Solar-battery integration,” 1st International Conference on Power Electronics and Energy (ICPEE), Bhubaneswar, India, 2-3 January 2021.
- [53] Aastha Kapoor, Priyanka Gangwar, Ankush Sharma, and Abheejeet Mohapatra, “Multi-Objective Framework for Optimal Scheduling of Electric Vehicles” 21st National Power Systems Conference (NPSC 2020), Gandhinagar, Gujarat, India, 17-19 December 2020.
- [54] Vineeth Vijayan, Abheejeet Mohapatra, and S. N. Singh, “A Metaheuristic Approach for Conservation Voltage Reduction in Unbalanced Active Distribution Networks,” 21st National Power Systems Conference (NPSC 2020), Gandhinagar, Gujarat, India, 17-19 December 2020.
- [55] O. Ray, M. S. Rana, S. Mishra, K. Davies, and S. Sepasi, “Battery-swap Technology for e-Rickshaws: Challenges, Opportunity and Scope,” 21st National Power Systems Conference (NPSC) 2020, Gandhinagar, Gujarat, India, 17-19 December 2020.
- [56] Ramanuja Panigrahi, Yash Verma; Santanu K. Mishra, Ankush Sharma, and Anju Meghwani, “A Fiber Optic Communication Module to Interface RTDS with Power Amplifier for PHIL Simulations,” 21st National Power Systems Conference (NPSC) 2020, Gandhinagar, Gujarat, India, 17-19 December 2020.
- [57] Nilesh Hadiya, Vartika Kulshreshtha, Rohit Bhakar, Ghan Vashishtha, and Alekhya Datta, “Blockchain: Elements of Physical Architecture, Empowering Features and Applications in the Indian Power Sector,” 21st National Power Systems Conference (NPSC) 2020, Gandhinagar, Gujarat, India, 17-19 December 2020.
- [58] Suman Biswal, Nikhil Kumar Sharma, and S. R. Samantaray, “Optimal Overcurrent Relay Coordination Scheme for Microgrid,” 21st National Power Systems Conference (NPSC) 2020, Gandhinagar, Gujarat, India, 17-19 December 2020.
- [59] Anju Meghwani, S.C. Srivastava, and A. Srivastava, “Development of Real-Time Distribution System Testbed using Co-Simulation,” 21st National Power Systems Conference (NPSC 2020), Gandhinagar, Gujarat, India, 17-19 December, 2020.
- [60] Avinash Kumar, A. Mohapatra, and S. N. Singh, “Improved Detection Time and Performance of Frequency Relay for Islanding Detection of DG,” 21st National Power Systems Conference (NPSC 2020), Gandhinagar, Gujarat, India, 17-19 December, 2020.
- [61] S. Maganti and N. P. Padhy, “A Flexible Compensation Strategy for Weak Grid-Tied Current Controlled Converters Under Unbalanced and Harmonic Conditions,” Power Electronics, Drives, and Energy Systems Conference (PEDES) MNIT Jaipur, Rajasthan, India, 16-19 December 2020.
- [62] S. Singh, S. Kewat, B. Singh and B. K. Panigrahi, “Adaptive Based Leaky LMS Control Technique of Grid Connected SPV System,” Power Electronics, Drives, and Energy Systems Conference (PEDES) MNIT Jaipur, Rajasthan, India, 16-19 December 2020.

- [63] V. Narayanan, and B. Singh, “Multifunctional Adaptive Control Strategy for a Standalone Hybrid Microgrid”, Power Electronics, Drives, and Energy Systems Conference (PEDES) MNIT Jaipur, Rajasthan, India, 16-19 December 2020.
- [64] Hariharan R. and Mahesh K. Mishra, "An Integrated Control of Enhanced-PLL and Synchronverter for Unbalanced Grid", Power Electronics, Drives, and Energy Systems Conference (PEDES) MNIT Jaipur, Rajasthan, India, 16-19 December 2020.
- [65] S Jena, N P Padhy and J M Guerrero, “Decentralized Primary and Distributed Secondary Control for Current Sharing and Voltage Regulation in DC Microgrid Clusters with HESS”, Power Electronics, Drives, and Energy Systems Conference (PEDES) MNIT Jaipur, Rajasthan, India, 16-19 December 2020.
- [66] V. Narayanan, and B. Singh, “An Adaptive Control Strategy for Remotely Located Microgrid Comprised of Solar PV-Battery Storage-Synchronous Generator Based DG Set,” International Conference on Power Instrumentation Control and Computing (PICC-2020), Kerala, India, 10-12 December 2020.
- [67] Ramanuja Panigrahi, Santanu K. Mishra and Avinash Joshi, "Inverse Problem of Converter Synthesis: Formulation, Complexities, and Solution,” in Symposium on Power Electronic and Renewable Energy Systems Control (PERESC) 2020, Bhubaneswar, India, 4-5 December 2020.
- [68] S. Karmakar, and B. Singh, “Fundamental Frequency Switched NPC-PST Based 24-Pulse VSC with PVSTATCOM Feature for Large-Scale Solar PV Plant,” Presented in 7th IEEE Uttar Pradesh Section International Conference on Electrical, Electronics and Computer Engineering (UPCON 2020), MNIT.
- [69] Viresh S. Patel, Anju Meghwani, Suresh C. Srivastava and Ankush Sharma, “Optimal Planning of Energy Storage System in a PV Integrated Semi-Urban Microgrid Pilot”, Proceedings of the 4th International Conference on Energy Harvesting, Storage, and Transfer (EHST 20), 15-17 November, 2020.
- [70] Nachiketa Deshmukh, and Sandeep Anand, “A Cascaded Interleaved Bootstrapped Gate Driver Power Supply for Multilevel Photovoltaic Inverters,” IEEE 21st Workshop on Control and Modeling for Power Electronics (COMPEL), Aalborg, Denmark, 9-12 November 2020.
- [71] V. Narayanan and B. Singh, “Solar PV Array-BES Integrated AC Microgrid with Seamless Transition to DG Set,” IEEE 5th International Conference on Computing Communication and Automation (ICCCA), Greater Noida, India, 30-31 October, 2020
- [72] F. Chishti, B. Singh and S. Murshid, “Adaptive PR and BBO Based Control Strategy of Wind-Solar Integrated Standalone Microgrid for Residential Application”, IEEE Energy Conversion Congress and Exposition (ECCE), Detroit, MI, USA, 11-15 October, 2020.
- [73] Kripa Tiwari, Seema and Bhim Singh, “VSS-DNSE Adaptive Control Algorithm for Enhancing Performance of PV-Grid Interfaced Converter,” IEEE Energy Conversion Congress and Exposition (ECCE), Detroit, MI, USA, 11-15 October, 2020.
- [74] Ramanuja Panigrahi, Santanu K. Mishra, and Avinash Joshi, “Synthesizing a Comprehensive Set of Converter Topologies for a Specified Voltage Gain”, 2020 IEEE Energy Conversion Congress and Exposition (ECCE), Detroit, MI, USA, 11-15 October, 2020
- [75] Hitesh Kumar, Santanu K. Mishra, and Mandeep Singh Rana, “Design of Harmonic Tolerant Mock-Up-Load for Distribution System Testbed”, 2020 IEEE Energy Conversion Congress and Exposition (ECCE), Detroit, MI, USA, 11-15 October, 2020.
- [76] S. Singh, S. Kewat, B. Singh and B. K. Panigrahi, “Adaptive LMAT Control Approach for Grid Coupled SPV System,” IEEE International Conference on Computing, Power and Communication Technologies (GUCON), Greater Noida, India, 2-4 October, 2020.
- [77] Nilesh Hadiya, Falti Teotia, Rohit Bhakar, Parul Mathuria, and Alekhya Datta, “A Comparative Analysis of Pricing Mechanisms to Enable P2P Energy Sharing of Rooftop Solar Energy,” IEEE International Conference on Power Systems Technology (POWERCON), Bangalore, India, 14-16 September 2020.
- [78] Bhim Singh, Vivek Narayanan, Seema, A. Chandra and Kamal Al-Haddad, “A TPFW Solar PV-BSS-DG set Based Microgrid with Power Quality Improvement and Maximum Power Extraction Capability,” IEEE Power & Energy Society General Meeting (PESGM), Montreal, Canada, during August 3-6, 2020.

- [79] Garvis Garg, Abheejeet Mohapatra, Saikat Chakrabarti, Avinash Kumar, and Rakesh Kumar Panda, "Optimal Day-Ahead Load Scheduling for Voltage and Frequency Regulation in an Islanded Microgrid", IEEE Power & Energy Society General Meeting (PESGM), Montreal, Canada, during August 3-6, 2020.
- [80] S Paul and N P Padhy, "Residential Flat Building Energy Management under Random Energy Price, Solar Generation and Load", IEEE Power & Energy Society General Meeting (PESGM), Montreal, Canada, during August 3-6, 2020.
- [81] S Paul and N P Padhy, "Impact Assessment of Real Time Demand Control on Active AC/DC Hybrid Distribution Networks", IEEE Power & Energy Society General Meeting (PESGM), Montreal, Canada, during August 3-6, 2020.
- [82] Avinash. Kumar, R. K. Panda, A. Mohapatra and S. N. Singh, "Lissajous Parameters based Islanding Detection of Multiple DGs in Microgrid", IEEE Power & Energy Society General Meeting (PESGM), Montreal, Canada, during August 3-6, 2020.
- [83] R. Dutta, S. Som, S. Chakrabarti, A. Sharma, and A. Srivastava, "Event Detection and Localization in Active Distribution Networks using  $\mu$  PMUs", IEEE Power & Energy Society General Meeting (PESGM), Montreal, Canada, during August 3-6, 2020.
- [84] Satabdy Jena, N P Padhy, "Distributed Cooperative Control for Autonomous Hybrid AC/DC Microgrid Clusters Interconnected via Back-to-back Converter Control", IEEE Power & Energy Society General Meeting (PESGM), Montreal, Canada, during August 3-6, 2020.
- [85] P. Paul and M. R. Bhatnagar, "DF Relaying in Cooperative Free Space Optical Communication System in Presence of Jammer," 2020 12th International Symposium on Communication Systems, Networks and Digital Signal Processing (CSNDSP), Porto, Portugal, 20-22 July, 2020.
- [86] D. M. Rao Korada and M. K. Mishra, "DC Bus Voltage Control in Hybrid AC/DC Microgrid System," 2020 IEEE International Conference on Environment and Electrical Engineering and 2020 IEEE Industrial and Commercial Power Systems Europe (EEEIC / I&CPS Europe), 9-12 June, 2020, Madrid, Spain.
- [87] F. Chishti, S. Murshid and B. Singh, "Grid Interaction of Wind Power Generation System Using Maximum-Likelihood Estimator Framework for Power Quality Improvement," IEEE 9th Power India International Conference (PIICON), SONEPAT, India, 28 February- 01 March, 2020.
- [88] Sambasivaiah Puchalapalli and B. Singh, "Dual Layer Least Mean Fourth Based Control of Grid-Interfaced Wind Turbine Coupled DFIG with Reduced Current Sensors", IEEE 9th Power India International Conference (PIICON), Sonapat, India, 28 February- 01 March, 2020.
- [89] V. Narayanan, Seema and B. Singh, "Implementation of a multi-objective control for islanded hybrid microgrid ", IEEE International Conference on Electrical and Electronics Engineering (ICE3), Gorakhpur, India, 14-15 February 2020.
- [90] Sai Sowmya Nagam, Rakesh Kumar Panda, Abheejeet Mohapatra, and Sandeep Anand, "Gaussian Process Regression based Fault Location in DC Microgrid," IEEE Texas Power and Energy Conference (TPEC), Texas A&M, College Station, TX, USA, 6-7 February, 2020.
- [91] Rakesh Kumar Panda, Abheejeet Mohapatra, Suresh Chandra Srivastava, and Mladen Kezunovic, "Energy Function based Approach for Online Inertia Estimation Utilizing Synchrophasor Measurements", IEEE Texas Power and Energy Conference (TPEC), Texas A&M, College Station, TX, USA, February 6-7, 2020.
- [92] Sambasivaiah Puchalapalli and B. Singh, "Adaptive RSC Control through Rotor Currents Dynamics Linearization for WT Coupled DFIG", IEEE International Conference on Power Electronics, Smart Grid and Renewable Energy (PESGRE 2020), Cochin, Kerala, India, 2-4 January 2020.
- [93] N. Lokesh and Mahesh K. Mishra, "A Comparative Performance Study of Advanced PLLs for Grid Synchronization," IEEE International Conference on Power Electronics, Smart Grid and Renewable Energy (PESGRE 2020), Cochin, Kerala, India, 2-4 January 2020.
- [94] Ram Shankar Yallamilli, D. M. R. Korada, L. K. Vedula and Mahesh K. Mishra, "Effective Current Based Inverter Loss Computation and its Application for Energy Savings in a Microgrid Environment," IEEE International Conference on Power Electronics, Smart Grid and Renewable Energy (PESGRE 2020), Cochin, Kerala, India, 2-4 January 2020.
- [95] D. M. R. Korada, Mahesh K. Mishra and Ram Shankar Yallamilli, "Dynamic Energy Management in DC Microgrid using Composite Energy Storage System," IEEE International Conference on Power Electronics, Smart Grid and Renewable Energy (PESGRE 2020), Cochin, Kerala, India, 2-4 January 2020.

- [96] R. Prasad and N. P. Padhy, "Coordinated Frequency Controller Operation for DFIG based Wind Turbine Generator Control using Combination Selection Scheme," IEEE International Conference on Power Electronics, Smart Grid and Renewable Energy (PESGRE 2020), Cochin, Kerala, India, 2-4 January 2020.
- [97] M V Gururaj, Rashmi Prasad, N P Padhy," Power Hardware in Loop Experimentation for Asymmetrical Fault Ride Through analysis of Grid Connected DFIG Wind Turbine", IEEE International Conference on Power Electronics, Smart Grid and Renewable Energy (PESGRE 2020), Cochin, Kerala, India, 2-4 January 2020.
- [98] Satabdy Jena, N P Padhy," Performance Assessment of Reverse Droop Control for Multi-DER Cooperative DC Microgrid", PESGRE 2020, Cochin, 2-4 January 2020.
- [99] Krishna Chaithanya Bandla, Gururaj M V, and Narayana Prasad Padhy, "Decentralized and Coordinated Virtual Synchronous Generator control for Hybrid AC-DC Microgrids", IEEE International Conference on Power Electronics, Smart Grid and Renewable Energy (PESGRE 2020), Cochin, Kerala, India, 2-4 January 2020.
- [100] Krishna Chaithanya Bandla and Narayana Prasad Padhy, "Decentralized Control for Coordinated Power Management Among Multiple HESS in DC Microgrid", IEEE International Conference on Power Electronics, Smart Grid and Renewable Energy (PESGRE 2020), Cochin, Kerala, India, 2-4 January 2020.
- [101] Sanjeev Pannala, Narayana Prasad Padhy, and Anurag K Srivastava, "Effective Power Management Scheme for Isolated DC Microgrid", IEEE International Conference on Power Electronics, Smart Grid and Renewable Energy (PESGRE 2020), Cochin, Kerala, India, 2-4 January 2020.
- [102] Subho Paul, Abhimanyu Sharma and Narayana Prasad Padhy," Optimal Operation of a Converter Governed AC/DC Hybrid Distribution Network with DERs",IEEE International Conference on Power Electronics, Smart Grid and Renewable Energy (PESGRE 2020),Cochin, Kerala, India 2-4 January 2020.
- [103] Sunaina Singh, Seema, Bhim Singh and B.K.Panigrahi," Enhanced Comb-Frequency Locked Loop Based Control of Grid-Tied PV System", IEEE International conference on Power Electronics, Smart Grid and Renewable Energy (PESGRE 2020) Cochin, Kerala, India 2-4 January 2020.
- [104] Kripa Tiwari, Seema and Bhim Singh," CMPN Adaptive Control Algorithm for Double Stage PV-Grid Connected System" IEEE International conference on Power Electronics, Smart Grid and Renewable Energy (PESGRE 2020) Cochin, Kerala, India 2-4 January 2020.
- [105] V. Narayanan, Seema and B. Singh, "Multi-operational PV-BES-DG based microgrid with power quality improvement", IEEE International Conference on Power Electronics, Smart Grid and Renewable Energy (PESGRE2020), Cochin, India, 2-4 January 2020.
- [106] R. Dutta, P. Kundu, A. Srivastava, "Dynamic State and Parameter Estimation of Distributed Generators using Constraint Recursive Least Square Algorithm and micro-PMU Data", published in 2020 IEEE International conference on Power Electronics, Smart Grid and Renewable Energy (PESGRE 2020) was held in Cochin, Kerala, India from 2-4 January 2020.
- [107] Mukesh Kumar, Shashank Vyas and Alekhya Datta," A Review on Integration of Electric Vehicles into Smart Power Grid and Vehicle to Grid Impacts", In Proc. IEEE International Conference on Power Systems, Jaipur 20-22 December 2019.
- [108] Shaziya Rasheed and Abhijit R Abhyankar," Development of Nash Equilibrium for Profit Maximization Equilibrium Problem in Electricity Market", In Proc. IEEE 8th International Conference on Power Systems (ICPS), Jaipur 20-22 December 2019
- [109] Megha Gupta and Abhijit R Abhyankar," Transmission Contingency Selection Considering Impact of Uncertain Distributed Generation", In Proc. IEEE 8th International Conference on Power Systems (ICPS), Jaipur, 20-22 December 2019.
- [110] Ram Krishan, Neshwin Rodrigues, Shashank Vyas and Alekhya Datta," Battery Energy Storage System Operational Control for Distribution Transformer Overload Management", In Proc. IEEE International Conference on Power Systems, Jaipur 20-22 December 2019.
- [111] Ashish Kumar Sharma, Abhinav Jain, Neshwin Rodrigues, Alekhya Datta and Shashank Vyas," Evaluating the Smoothing Application of BESS for Large Solar Photovoltaic Parks", In Proc. IEEE International Conference on Power Systems, Jaipur 20-22 December 2019.

- [112] Subho Paul, Narayana Prasad Padhy, Santanu K. Mishra, and Anurag K. Srivastava, "UUCA: Utility-User Cooperative Algorithm for Flexible Load Scheduling in Distribution System", International Conference on Power Systems (ICPS 2019) Jaipur, India, 20-22 December 2019.
- [113] Satabdy Jena, N P Padhy, Suresh C. Srivastava, and Noel N. Schulz" A hybrid RC-droop control strategy for power sharing and voltage restoration in islanded DC microgrids", International Conference on Power Systems (ICPS 2019) Jaipur, India, 20-22 December 2019.
- [114] Sunaina Singh, Seema, Bhim Singh and B.K.Panigrahi," MRZA-LMM with IMTOGI Control for Grid Tied PV System", IEEE International Conference on Power Systems (ICPS 2019) Jaipur, India, 20-22 December 2019.
- [115] Sunil Kumar Bagudi, Olive Ray, and S R Samantaray, "Evaluation of Control Strategies within Hybrid DC/AC Microgrids using Typhoon HIL", 2019 8th International Conference on Power Systems (ICPS), MNIT Jaipur, India from 20-22 Dec. 2019.
- [116] Smrutirekha Samal, S.R. Samantaray, and M S Manikandan, "A DNN based Intelligent Protective Relaying Scheme for Microgrids", 2019 8th International Conference on Power Systems (ICPS), MNIT Jaipur, India from 20-22 Dec. 2019.
- [117] Neshwin Rodrigues, Jyoti Sharma, Shashank Vyas and Alekhya Datta," A Regulated Electric Vehicle Charging Scheme in Coordination with Utility Pricing and Transformer Loading", In Proc. IEEE International Transportation Electrification Conference India, Bengaluru,17-19 December 2019.
- [118] Mohanpurkar, Ram Krishan, Mayank Panwar, Shashank Vyas, Lee Slezak, Neshwin Rodrigues, Alekhya Datta, Andrew Meintz and Rob Hovsapian," Enabling Seamless Integration of EV Charging Infrastructure with Weak Electric Grids" In Proc. IEEE International Transportation Electrification Conference India, Bengaluru, 17-19 December 2019.
- [119] D. Rana and O. Ray," Analysis and Control of Integrated Dual-Boost Topology for Solar-Battery Integration", Proc. NPEC 2019, Trichy, pp.1-6, 13-15 December 2019
- [120] Satabdy Jena, N P Padhy," A Distributed Cooperative Droop Control Framework for Unified Operation of Shunt DC Electric Springs",NPEC 2019, Tirchy, 13-15 December 2019.
- [121] N. Lokesh and Mahesh K. Mishra, "A Robust Control Scheme for an Integrated Nine-Switch Power Quality Conditioner," 2019 National Power Electronics Conference (NPEC), Tiruchirappalli, India, 13-15 December 2019.
- [122] Subho Paul and Narayana Prasad Padhy, "A Multi-Objective Genetic Algorithm Approach for Synergetic Source-Storage-Load Dispatch in a Residential Microgrid", 20th International Conference on Intelligent System Application to Power Systems (ISAP), IIT Delhi, India, 10-14 December, 2019.
- [123] Rashmi Prasad and Narayana Prasad Padhy, "Data Derived Identification Methodology for Online Estimation of Parameters of Induction Machine", 20th International Conference on Intelligent System Application to Power Systems (ISAP), IIT Delhi, India, 10-14 December, 2019.
- [124] Nikhil Kumar Sharma and S. R. Samantaray,"Differential Impedance Angle Based Fault Detection in Microgrid", IEEE PES Asia-Pacific Power and Energy Engineering Conference (APPEEC), Macao, 2019 1-4 Dec. 2019.
- [125] D. M. R. Korada and Mahesh K. Mishra, "Design of Composite Energy Storage System for Wind Turbine under Gust," 2019 International Conference on Power Electronics, Control and Automation (ICPECA), New Delhi, India, 16-17 November 2019.
- [126] Neswhin Rodrigues, Shashank Vyas and Alekhya Datta,"Two-Stage Battery Energy Storage System Sizing for Distribution Transformer Overload Management", In Proc. IEEE Uttar Pradesh Section International Conference on Electrical, Electronics and Computer Engineering, Aligarh, 8-10 November 2019.
- [127] Sunaina Singh, Seema, Bhim Singh, B.K.Panigrahi, and Manoj Kumar Kushwaha," Enhanced IAF-PNLMS Based Control Algorithm for Power Quality Improvement in Weak Grid Interfaced Solar PV System", IEEE UPCON, Aligarh, India 8-10 November 2019.
- [128] Shaziya Rasheed and Abhijit R Abhyankar," Investigating the Effect of Load Modeling on Network Reconfiguration of a Distribution System", published in North American Power Symposium (NAPS) , Wichita, Kansas (USA), 13-15 October 2019.



- [129] Megha Gupta; A.R. Abhyankar,” Impact of Active Distribution Network on Contingency Analysis of Transmission System”, North American Power Symposium (NAPS) , Wichita, Kansas (USA) 13-15 October 2019 .
- [130] Vineeth Vijayan; Abheejeet Mohapatra; S.N. Singh, “Impact of Modes of Operation of Smart Inverters on Volt-VAR Optimization”, IEEE PES Innovative Smart Grid technologies Europe Conference, ISGT Europe – 2019, University POLITEHNICA of Bucharest, Romania, 29 September – 2 October,2019.
- [131] Gaurav Khare, Abheejeet Mohapatra, S. N. Singh, “Linearized Attack Vector Formulation against AC State Estimator”, IEEE PES Innovative Smart Grid Technologies Europe Conference, ISGT Europe – 2019, University POLITEHNICA of Bucharest, Romania, 29 September – 2 October, 2019.
- [132] Soumya Sahoo, Ankush Sharma, Saikat Chakrabarti, and Soumya Ranjan Sahoo,"Optimal Residential Battery Scheduling using Short-term Forecasts", IEEE PES Innovative Smart Grid technologies Europe conference, ISGT Europe – 2019, University POLITEHNICA of Bucharest, Romania from September 29 to October 2, 2019.
- [133] Aastha Kapoor, Rajarshi Dutta and Ankush Sharma,"Voltage Regulation in Distribution System using Demand Response", IEEE PES Innovative Smart Grid technologies Europe conference, ISGT Europe – 2019, University POLITEHNICA of Bucharest, Romania from September 29 to October 2, 2019.
- [134] D. Pal, B. K. Panigrahi and S. Kewat,” A Hybrid Method for Islanding Detection of Inverter Interfaced Distributed Generators Utilizing Superimposed”, IEEE Energy Conversion Congress and Exposition (ECCE), Baltimore, MD, USA, pp. 1020-1025. 29 September -3 October, 2019
- [135] Subho Paul, Narendra Babu Y, Narayana Prasad Padhy,” Day Ahead Bi-Level Direct Load Control in Smart Residential Apartment Building: A Stackelberg Game Approach”, International Conference on Computing, Power and Communication Technologies (GUCON) Galgotias University, Greater Noida, UP, India., Sep 27-28, 2019.
- [136] P. Paul, M. R. Bhatnagar, and A. Jaiswal,” Performance of free space optical communication system under jamming attack and its mitigation over non-Gaussian noise channel”, IEEE 90th Vehicular Technology Conference (VTC2019-Fall), 22-25 September 2019.
- [137] Neswhin Rodrigues, Ram Krishan, Ashish Kumar Sharma, Shashank Vyas, Shubham Thakare and Alekhya Datta,” Evaluating the Application of BESS for Peak Load Management of a Distribution Transformer”, In Proc. 2nd International Conference on Large-Scale Grid Integration of Renewable Energy in India, New Delhi, 4-6 September 2019.
- [138] Sweta Malik, Shashank Vyas, Alekhya Datta and Amanda Ahl,” P2P Trading using DERs: A Holistic View of Global Practices and Pioneering Efforts in India”, In Proc. 2nd International Conference on Large-Scale Grid Integration of Renewable Energy in India, New Delhi,4-6 September 2019
- [139] A. Meghwani, J. G. Sreenath, S. C. Srivastava, S. Chakrabarti and A. Sharma,, "Robust Event Detection using Synchrophasor Assisted Forecasting-Aided State Estimation",IEEE Power & Energy Society General Meeting (PESGM), Atlanta, GA, USA, 4-8 Aug. 2019.
- [140] Avinash. Kumar, B. R. Kumar, R. K. Panda, A. Mohapatra and S. N. Singh, "Phaselet Approach for Islanding Detection in Active Distribution Networks," IEEE Power & Energy Society General Meeting (PESGM), Atlanta, GA, USA, 4-8 Aug. 2019.
- [141] Megha Gupta, Kush Khanna, A. R. Abhyankar, B.K. Panigrahi, "Real-time Validation of Distributed AC OPF for Coupled Transmission-Distribution System ", IEEE Power & Energy Society General Meeting (PESGM), Atlanta, GA, USA, 4-8 Aug. 2019.
- [142] Satadby Jena, N P Padhy, "A Reverse Droop Based Distributed Control Framework for DC Distribution Systems",IEEE Power & Energy Society General Meeting (PESGM), Atlanta, GA, USA, 4-8 Aug. 2019.
- [143] Homanga Bharadwaj, Avinash Kumar and Abheejeet Mohapatra, "A Synchrophasor Assisted Optimal Features Based Scheme for Fault Detection and Classification",International Joint Conference on Neural Networks ,14-19 July 2019 to be held in Budapest, Hungary
- [144] Nalla Lokesh, Mahesh K. Mishra and Nafih Muhammad Ismail, “Variable Structure Control for Three Phase-Three Wire Nine Switch Converter with LCL Filter”, IEEE 13th International Conference on Power Electronics and Drives Systems (PEDS), Toulouse, France, 9-12 July, 2019

- [145] Nafih M. Ismail and Mahesh. K. Mishra, "Control and Operation of Multifunctional DSTATCOM with Battery-Supercapacitor Energy Storage System," IEEE 13th International Conference on Power Electronics and Drive Systems (PEDS), 9-12 July, 2019, Toulouse, France
- [146] Mahamad Nabab Alam, Saikat Chakrabarti, Ankush Sharma, and Suresh Chandra Srivastava, "An Adaptive Protection Scheme for AC Microgrids Using  $\mu$ PMU Based Topology Processor," IEEE International Conference on Environment and Electrical Engineering and IEEE Industrial and Commercial Power Systems Europe (EEEIC / I&CPS Europe), Genova, Italy, 11-14 June 2019.
- [147] V. Narayanan, S. Kewat and B. Singh, "Standalone PV-BES-DG Based Microgrid with Power Quality Improvements," IEEE International Conference on Environment and Electrical Engineering and IEEE Industrial and Commercial Power Systems Europe (EEEIC / I&CPS Europe), Genova, Italy, 11-14 June 2019.
- [148] Rohit Negi ; Parvin Kumar ; Shibashis Ghosh ; Sandeep K. Shukla ; Ashish Gahlot, "Vulnerability Assessment and Mitigation for Industrial Critical Infrastructures with Cyber Physical Test Bed" Published In IEEE International Conference on Industrial Cyber Physical Systems (ICPS 2019), Taipei, Taiwan from 6-9 May, 2019. DOI: 10.1109/ICPHYS.2019.8780291
- [149] Rakesh Kumar Panda, Abheejeet Mohapatra and S. C. Srivastava, "Application of Indirect Adaptive Control Philosophy for Inertia Estimation ",IEEE PES Generation Transmission and Distribution Conference, GTD 2019, 23 March 2019, Bangkok, Thailand
- [150] Ankit Shukla, Anubrata Das, Sandeep Anand, "Method to Reduce Harmonic Voltage Distortion and Improve Harmonic Current Sharing in an islanded AC Microgrid", IEEE International Conference on Industrial Technology (ICIT), 13-15, February 2019
- [151] Alekhya Datta, "Energy Storage Solutions for Mission Critical Infrastructure", Energy Storage India 2019, 10-11 January 2019, New Delhi India
- [152] Mukesh Kumar, Vishu Gupta, Rajesh Kumar, B.K. Panigrahi, "Customer Oriented Electric Vehicle Charging Scheduling In Day-ahead Market Via Aggregative Game Model," 2018 8th IEEE India International Conference on Power Electronics (IICPE), 13-15 Dec. 2018
- [153] M V Gururaj, Narayana Prasad Padhy, "Power Hardware in Loop based experimentation on DFIG wind system integrated to isolated DC microgrid", 2018 Power Electronics, Drives, and Energy Systems Conference (PEDES) IIT Madras, Chennai, India, 18 – 21 December 2018.
- [154] Hariharan R and Mahesh K. Mishra, "An Inbuilt Synchronization Controller for Three-Phase Synchronverters" ,Power Electronics, Drives and Energy Systems Conference (PEDES), IIT Madras, Chennai, 18-21 December, 2018
- [155] Hussain, J. and Mahesh K. Mishra, "Sliding Mode Observers Based Wind Speed Computation Method in Wind Energy Conversion Systems Control Applications", Power Electronics, Drives and Energy Systems Conference (PEDES), IIT Madras, Chennai, 18-21 December, 2018
- [156] Avinash Kumar, Abheejeet Mohapatra and S. N. Singh, "High Speed Differential Protection of Series-Shunt Compensated Transmission Line using Phaselet", 15th IEEE India Council International Conference (INDICON 2018), 15-18 December, 2018, Amrita Vishwa Vidyapeetham, Combatore, India
- [157] Rakesh Kumar Panda, Abheejeet Mohapatra and S. C. Srivastava, "Impact of VSG Parameters on Transient Performance of Solar PV based System", 20th National Power Systems Conference, NPSC 2018, 14-16 December, 2018, NIT Trichy, India
- [158] Akansha Jain, Tanmay Tewari, Anubrata Das, Sandeep Anand and Abheejeet Mohapatra, "Coordinated Voltage Control in LV Distribution Systems using OLTC and BESS ", 20th National Power Systems Conference, NPSC 2018, 14-16 December, 2018, NIT Trichy, India
- [159] Megha Gupta, A. R. Abhyankar, "Coordinated Load Flow Solution for Coupled Transmission-Distribution System Incorporating Load Modeling", 20th National Power Systems Conference, NPSC 2018, 14-16 December, 2018, NIT Trichy, India
- [160] Debasish Dhua, A. B. Shyam, Sandeep Anand and Soumya Ranjan Sahoo, "Dynamic Overcurrent Saturation of Distributed Sources in a DC Microgrid System", 20th National Power Systems Conference, NPSC 2018, 14-16 December, 2018, NIT Trichy, India

- [161]** Subho Paul, Archana Tamrakar and Narayana Prasad Padhy, "Demand Side Management Based Optimal Scheduling Portfolio of a Microgrid in Linear Programming Platform", 20th National Power Systems Conference, NPSC 2018 , 14-16 December, 2018, NIT Trichy, India
- [162]** Shaziya Rasheed, Megha Gupta, A. R. Abhyankar, "Feeder Voltage Dependent Distribution Network Reconfiguration for Loss Reduction" , 20th National Power Systems Conference, NPSC 2018 , 14-16 December, 2018, NIT Trichy, India
- [163]** Vivek Narayanan, Seema, Bhim Singh, "Multifunctional Capability with Seamless Transition of Three-Phase Grid using FLMF Control Approach" ,8th IEEE India International Conference on Power Electronics (IICPE-2018), 13-15 December 2018, Jaipur, India
- [164]** Jyoti Sharma, Vivek Prakash, Priyanka Kushwaha and Rohit Bhakar, "Primary Frequency Response Constrained Interruptible Load Scheduling under PV Generation", 8th IEEE India International Conference on Power Electronics, 13-15, December 2018
- [165]** S. Singh, S. B. Singh, B. K. Panigrahi and M. K. Kushwaha, "Enhanced IAF-PNLMS Based Control Algorithm for Power Quality Improvement in Weak Grid Interfaced Solar PV System," 8th IEEE India International Conference on Power Electronics (IICPE-2018), MNIT, Jaipur, India, 13-15 December, 2018.
- [166]** S. Singh, Seema, B. Singh, B. K. Panigrahi and M. K. Kushwaha, "Recursive Least M-Estimate based Control Algorithm for Grid Interfaced Solar PV System," 8th IEEE Power India International Conference (PIICON-2018), NIT Kurukshetra, Haryana, India, 10-12 December, 2018.
- [167]** Subho Paul, Sachin Choudhary and Narayana Prasad Padhy, "A Review on Residential Area Demand Response Analysis in Smart Grid Era", 8th IEEE Power India International Conference (PIICON-2018), 10-12 December, 2018, NIT Kurukshetra, Haryana, India
- [168]** Vivek Narayanan, Seema, Bhim Singh, "Real Time Implementation of CLMS Algorithm in 3P4W Solar PV-BES Based Microgrid System", 8th IEEE Power India International Conference (PIICON-2018), 10-12 December, 2018, NIT Kurukshetra, Haryana, India
- [169]** K. Murari and N. P. Padhy, "Framework for Assessing the Economic Impacts of AC-DC Distribution Network on the Consumers", 59th IEEE International Scientific Conference on Power and Electrical Engineering of Riga Technical University, Riga, Latvia., 12-14 November 2018, Riga Technical University, Riga, Latvia
- [170]** Vivek Narayanan, Seema, Bhim Singh, "Solar PV - BES Based Microgrid System with Multifunctional VSC" ,5th IEEE Uttar Pradesh Section International Conference on Electrical, Electronics and Computer Engineering (UPCON), 2-4 November 2018, Gorakhpur, India
- [171]** Vivek Narayanan, Seema, Bhim Singh, "Solar PV-BES Based Microgrid System with Seamless Transition Capability" 2nd IEEE International conference on power Electronics, Intelligent Control and Energy Systems (ICPEICES-2018), 22-24 October 2018, Delhi, India
- [172]** Ramanuja Panigrahi, Santanu K. Mishra, and S. C. Srivastava, "Grid Integration of Small-Scale Photovoltaic Systems: A Review", IEEE- IAS Annual Meeting 2018, Portland, USA, 23-27 Sep 2018.
- [173]** K. C. Bandla, and N. P. Padhy, "A Multilevel Dual Converter fed Open end Transformer Configuration for Hybrid AC-DC Microgrid", 2018 IEEE Power & Energy Society General Meeting, Portland, USA, 5-9 Aug 2018
- [174]** Rakesh Kumar Panda, Abheejeet Mohapatra and S. C. Srivastava, "An Effective Inertia Control Scheme for Solar PV Systems with Conventional dq Controller", IEEE PES General Meeting, Portland, USA, 5-9 Aug 2018
- [175]** J. G. Sreenath, S. Mangalwedekar, A. Meghwani, S. Chakrabarti, K. Rajawat and S. C. Srivastava, "Impact of GPS Spoofing on Synchrophasor Assisted Load Shedding" IEEE PES General Meeting, Portland, USA, 5-9 Aug 2018
- [176]** P Sanjeev, Narayana Prasad Padhy, and Pramod Agarwal "A New Architecture for DC Microgrids using Supercapacitor," 9th IEEE International Symposium on Power Electronics for Distributed Generation Systems (PEDG), Charlotte, NC, USA, 25-28 June 2018.
- [177]** H. S. Sahu and Mahesh K. Mishra, "Maximum Power Output from a Solar PV Array Under Partially Shaded Conditions," IEEE Transportation Electrification Conference and Expo, Asia-Pacific (ITEC Asia Pacific), Bangkok, 6-9 June 2018

- [178] M. Pradhan and Mahesh K. Mishra, "Dual P-Q Theory based Energy Optimized Dynamic voltage restorer with battery management features", The International Conference on Innovative Smart Grid Technologies (IEEE PES ISGT Asia 2018), 22-25 May, 2018
- [179] Shyam A.B., AnoopIngle, SoumyaRanjanSahoo, and S. Anand, "Performance Analysis of ReducedCommunication Network in DC Microgrid," IEEE PES Innovative Smart Grid Technologies Asia Conference, ISGT-Asia'2018, Singapore, 22-25 May 2018.
- [180] A. Kapoor and A. Sharma, "A Comparison of Short-Term Load Forecasting Techniques", IEEE PES Innovative Smart Grid Technologies Asia Conference, ISGT-Asia'2018, Singapore, 22-25 May 2018
- [181] Anju Meghwani, SaikatChakrabarti, and S. C. Srivastava, "An On-line Fault Location Technique for DC MicrogridUsing Transient Measurements", 7th International Conference on Power Systems, 2017 (ICPS 2017), Pune, India, 21-23 Dec 2017
- [182] Anju Meghwani, SaikatChakrabarti, S. C. Srivastava, and S. Anand, "Analysis of Fault Characteristics in DC Microgrids for Various Converter Topologies", 7th Innovative Smart Grid Technologies (ISGT Asia 2017), Auckland, New Zealand, 4-7 Dec 2017
- [5] C. Qin, L. Jia, S. Bajagain, S. Pannala, A. K. Srivastava and A. Dubey, "An Integrated Situational Awareness Tool for Resilience-Driven Restoration With Sustainable Energy Resources," in IEEE Transactions on Sustainable Energy, vol. 14, no. 2, pp. 1099-1111, April 2023, doi: 10.1109/TSTE.2023.3239604..
- [6] Potter, A., Haider, R., Ferro, G., Robba, M. and Annaswamy, A.M., 2023. A reactive power market for the future grid. *Advances in Applied Energy*, 9, p.100114.
- [7] Muaddi, Saad, and Chanan Singh. "Investigating capacity credit sensitivity to reliability metrics and computational methodologies." *Applied Energy* 325 (2022): 119825.
- [8] M. Soleimani, M. Kezunovic and S. Butenko, "Linear Arrhenius-Weibull Model for Power Transformer Thermal Stress Assessment," in IEEE Access, vol. 10, pp. 19013-19021, 2022, doi: 10.1109/ACCESS.2022.3150039
- [9] M. Khoshjahan, and M. Kezunovic, "Robust Bidding Strategy for Aggregation of Distributed Prosumers in Flexiramp Market," *Electric Power Systems Journal*, Vol. 209, 107994, August 2022.
- [10] S. A. Muaddi and C. Singh, "Reliability Constrained Optimal Sizing and Examining Capacity Credit and Alternatives for Renewable Energy Sources," in IEEE Access, vol. 10, pp. 71133-71142, 2022, doi: 10.1109/ACCESS.2022.3188676 .

---

## Journals - US

- [1] P. Srivastava, R. Haider, V.J. Nair, V. Venkataramanan, A.M. Annaswamy, and A.K. Srivastava, "Voltage regulation in distribution grids: A survey." *Annual Reviews in Control* 2023. doi: 10.1016/j.arcontrol.2023.03.008
- [2] M. Khoshjahan, R. Baembitov and M. Kezunovic, "Informed prosumer aggregator bidding strategy via incorporating distribution grid outage risk predictions," *IEEE Access*, Vol. 11, pp. 28585-28595, March 2023.
- [3] Karngala, Arun Kumar, and Chanan Singh. "Impact of system parameters and geospatial variables on the reliability of residential systems with PV and energy storage." *Applied Energy* 344 (2023): 121266. <https://doi.org/10.1016/j.apenergy.2023.121266>.
- [4] J.I. Cisneros, S. Samal, S.R. Samantaray , M. M. Begovic, "On Protection Schemes for AC Microgrids: Challenges and Opportunities", 2023 *IEEE Transactions on Industry Applications*
- [11] S. Majumder, G. Kandaperumal, S. Pandey, A. K. Srivastava and C. Koplín, "Pre-Event Two-Stage Proactive Control for Enhanced Distribution System Resiliency," in IEEE Access, vol. 10, pp. 83281-83296, 2022, doi: 10.1109/ACCESS.2022.3195492.
- [12] Saa Muaddid , C.Singh,"Investigating Capacity Credit Sensitivity to Reliability Metrics and Computational Methodologies", *Applied Energy*, (in publication process)
- [13] N. Patari, V. Venkataramanan, A.K. Srivastava, D.K. Molzahn, N. Li , A. Annaswamy, "Distributed Optimization in Distribution Systems: Use Cases, Limitations and Research Needs", in *IEEE Transactions on Power Systems* (published)
- [14] Niloy Patari, Dr. Anurag K. Srivastava and Na. Li` "Distributed Optimal Voltage Control Considering Latency and Asynchronous Communication for Three Phase Unbalanced Distribution Systems" in *IEEE Transactions on Power Systems* (revision 2)

- [15] S. Pannala, A. Srivastava, G. Kandaperumal and S.K. Sadanandan "DINGO: Digital Assistant to Grid Operators for Resilience Management of Power Distribution System" *Electric Power Systems Research Journal*, Elsevier vol. 210, pp. 108076, May. 2022
- [16] Vosughi, A. Tamimi, A. B. King, S. Majumder, and A. K. Srivastava, "Cyber-physical Vulnerability and Resiliency Analysis for DER Integration: A Review, Challenges and Research Needs," accepted for publication in *Renew. Sust. Energ. Rev.*
- [17] L. Jia, S. Pannala, G., Kandaperumal and A. K. Srivastava, "Coordinating Energy Resources in an Islanded Microgrid for Economic and Resilient Operation," in *IEEE Transactions on Industry Applications*, doi: 10.1109/TIA.2022.3154337.
- [18] R. Haider and A.M. Annaswamy, "A Hybrid Architecture for volt-var control in active distribution grids." In *Applied Energy* 2022. doi: 10.1016/j.apenergy.2022.118735
- [19] V. J. Nair, V. Venkataramanan, R. Haider and A. M. Annaswamy, "A Hierarchical Local Electricity Market for a DER-rich Grid Edge," in *IEEE Transactions on Smart Grid*, doi: 10.1109/TSG.2022.3174036
- [20] J. Nsengiyaremye, B. C. Pal and M. M. Begovic, "Low-Cost Communication-Assisted Line Protection for Multi-Inverter Based Microgrids," in *IEEE Transactions on Power Delivery*, vol. 36, no. 6, pp. 3371-3382, Dec. 2021, doi: 10.1109/TPWRD.2020.3039176.
- [21] G. Ferro, M. Robba, R. Haider, A.M. Annaswamy, "A distributed optimization based architecture for management of interconnected energy hubs." In *IEEE TCNS* 2022. doi: 10.1109/TCNS.2022.3165022
- [22] C. Qin, S. Bajagain, S. Pannala, A. Srivastava, and A. Dubey "Enhanced Situational Awareness for DER-Rich Distribution Systems under Pre- and Post-Outage," *IEEE Transactions on Power Delivery* 2021, PP 1–15 (Accepted). doi: 10.1109/TPWRD.2022.3197170.
- [23] J. Romvary, G. Ferro, R. Haider, and A.M. Annaswamy, "A distributed proximal atomic coordination algorithm." In *IEEE Transactions on Automatic Control*, 2021. doi: 10.1109/TAC.2021.3053907
- [24] Horne, Christine, and Emily Kennedy. 2021. "Understanding the Rebound: Normative Evaluations of Energy Use in the United States." *Environmental Sociology*. <https://doi.org/10.1080/23251042.2021.1958545>
- [25] P. S. Nirbhavane, L. Corson, S. M. H. Rizvi and A. K. Srivastava, "TPCPF: Three-Phase Continuation Power Flow Tool for Voltage Stability Assessment of Distribution Networks With Distributed Energy Resources," in *IEEE Transactions on Industry Applications*, vol. 57, no. 5, pp. 5425-5436, Sept.-Oct. 2021, doi: 10.1109/TIA.2021.3088384.
- [26] Noorazar H, Srivastava A, Pannala S, K Sadanandan S. Data-driven operation of the resilient electric grid: A case of COVID-19. *J Eng (Stevenage)*. 2021 Aug 9;10.1049/tje2.12065. doi: 10.1049/tje2.12065.
- [27] R. Haider, D. D'Achiardi, V. Venkataramanan, A. Srivastava, A. Bose, and A. M. Annaswamy, "Reinventing the Utility for Distributed Energy Resources: A Proposal for Retail Electricity Markets," *Advances in Applied Energy*, May 2021.
- [28] Horne, Christine and Thomas Familia. 2021. "Norms, Norm Sets, and Reference Groups: Implications for Household Interest in Energy Technologies." *Socius*. <https://doi.org/10.1177/23780231211039035>
- [29] H. Ren, R. R. Jha, A. Dubey and N. N. Schulz, "Extremum-Seeking Adaptive-Droop for Model-free and Localized Volt-VAR Optimization," in *IEEE Transactions on Power Systems*, doi: 10.1109/TPWRS.2021.3093831.
- [30] W. Li, D.W. Limoge, J. Zhang, D.U. Sauer, and A.M. Annaswamy, "Estimation of Potentials in Lithium-Ion Batteries Using Machine Learning Models," *IEEE Transactions on Control Systems Technology*, 2021
- [31] N. Patari, A. K. Srivastava, G. Qu and N. Li, "Distributed Voltage Control for Three-Phase Unbalanced Distribution Systems with DERs and Practical Constraints," in *IEEE Transactions on Industry Applications*, doi: 10.1109/TIA.2021.3114388
- [32] G. Kandaperumal, S. Pandey and A. Srivastava, "AWR: Anticipate, Withstand, and Recover Resilience Metric for Operational and Planning Decision Support in Electric Distribution System," in *IEEE Transactions on Smart Grid*, doi: 10.1109/TSG.2021.3119508.
- [33] R. Saeedi, S. K. Sadanandan, A. K. Srivastava, K. L. Davies and A. H. Gebremedhin, "An Adaptive Machine Learning Framework for Behind-the-Meter Load/PV Disaggregation," in *IEEE Transactions on Industrial Informatics*, vol. 17, no. 10, pp. 7060-7069, Oct. 2021, doi: 10.1109/TII.2021.3060898.

- [34] Horne, Christine, Emily Huddart Kennedy, and Thomas Familia. Forthcoming. "Rooftop Solar in the United States: Exploring Trust, Utility Perceptions, and Adoption among California Homeowners." *Energy Research and Social Science*.
- [35] A.K. Karngala, C. Singh, "Reliability Assessment Framework for the Distribution System Including Distributed Energy Resources.", *IEEE Transactions on Sustainable Energy*. Volume: 12, Issue: 3, PP. 1539 - 1548, July 2021 .
- [36] J. Romvary, G. Ferro, R. Haider, and A.M. Annaswamy. "A Proximal Atomic Coordination Algorithm for Distributed Optimization," *IEEE Transactions on Automatic Control ( Early Access )*, DOI: 10.1109/TAC.2021.3053907
- [37] S. Pannala, N. P. Padhy and P. Agarwal, "Effective power management scheme for PV-Battery-DG integrated standalone DC microgrid," in *IET Electric Power Applications*, Volume 14, Issue 12, PP. 2322 – 2330, December 2020, <https://doi.org/10.1049/iet-epa.2020.0140>
- [38] P. Sanjeev, N. Patari, Anurag K Srivastava, and N. P. Padhy, "Effective Control and Management Scheme for Isolated DC Microgrid," *IEEE Transactions on Industry Applications*, Vol, PP, 1-14, August 2020, DOI: 10.1109/TIA.2020.3015819 ( Early Access )
- [39] M. Soleimani, M. Kezunovic, " Mitigating Transformer Loss of Life and Reducing the Hazard of Failure by the Smart EV Charging," in *IEEE Transactions on Industry Applications*, page(s): 0, Print ISSN: 0093-9994, Online ISSN: 1939-9367, Digital Object Identifier: 10.1109/TIA.2020.2986990 ( Early Access )
- [40] J. Nsengiyaremye, B. C. Pal and M. M. Begovic, "Microgrid Protection Using Low-Cost Communication Systems," in *IEEE Transactions on Power Delivery*, vol. 35, no. 4, pp. 2011-2020, August 2020
- [41] Shikhar Pandey, Sayonsom Chanda, Anurag K. Srivastava and Rob O. Hovsopian, "Resiliency-Driven Proactive Distribution System Reconfiguration With Synchrophasor Data," in *IEEE Transactions on Power Systems*, Volume: 35, Issue: 4, July 2020 .
- [42] R. Haider, S. Baros, Y. Wasa, J. Romvary, K. Uchida and A. M. Annaswamy, "Towards a Retail Market for Distribution Grids," in *IEEE Transactions on Smart Grid*, May 2020 (Early Access).
- [43] D. J. S. Cardenas, A. Hahn and C. Liu, "Assessing Cyber-Physical Risks of IoT-Based Energy Devices in Grid Operations," in *IEEE Access*, vol. 8, pp. 61161-61173, 2020.
- [44] R. Panigrahi, S. K. Mishra, S. C. Srivastava, A. K. Srivastava, and N. N. Schulz, "Grid Integration of Small-Scale Photovoltaic Systems in Secondary Distribution Network- A Review", *IEEE Transactions on Industry Applications*, 2019
- [45] M. Soleimani, M. Kezunovic, "Economic Evaluation of Transformer Loss of Life Mitigation by Energy Storage and PV Generation" *IEEE Transactions on Industry Applications*, Print ISSN: 0093-9994, Online ISSN: 1939-9367, Digital Object Identifier: 10.1109/TIA.2020.2986990
- [46] Jia, H., Ding, Y., Song, Y., Singh, C. and Li, M., 2018. "Operating Reliability Evaluation of Power Systems Considering Flexible Reserve Provider in Demand Side" published in 2018 *IEEE Transactions on Smart Grid*. DOI: 10.1109/TSG.2018.2827670
- [47] D. Urgun, C. Singh, V. Vittal, "Importance Sampling Using Multilabel Radial Basis Classification for Composite Power System Reliability Evaluation", published in *IEEE Systems Journal*, DOI: 10.1109/JSYST.2019.2944131
- [48] D. J. Sebastian, U. Agrawal, A. Tamimi, A. Hahn. "DERTEE: Secure Distributed Energy Resource Operations through Trusted Execution Environments" published in *IEEE Internet of Things Journal*. DOI: 10.1109/JIOT.2019.2909768.
- [49] Alismail, F., Xiong, P. and Singh, C., "Optimal Wind Farm Allocation in Multi-Area Power Systems Using Distributionally Robust Optimization Approach" published in *IEEE Transactions on Power Systems*, 33(1), pp.536-544. DOI : 10.1109/TPWRS.2017.2695002
- [50] A. Ahmed, S. Basumallik, A. Gholami, S. K. Sadanandan, M. H. N. Namaki, A. K. Srivastava, and Y. Wu, "Spatio-Temporal Deep Graph Network for Event Detection, Localization and Classification in Cyber-Physical Electric Distribution System", *IEEE Transactions on Industrial Informatics*, 2023
- [51] A Gholami, AK Srivastava, "ORCA: Outage Root Cause Analysis in DER-rich Power Distribution System Using Data Fusion, Hierarchical Clustering and FP-Growth Rule Mining", *IEEE Transactions on Smart Grid*, 2023

- [52] A. Vosughi, S. Pannala, and A. K. Srivastava, "Event Detection, Classification and Localization in an Active Distribution Grid using Data-Driven System Identification, Weighted Voting and Graph", IEEE Transactions on Smart Grid, 2023
- [53] S. Majumder, A. Vosughi, Md. M Hussain, T. Warner, A. Srivastava, "On the Cyber-Physical Needs of DER-based Voltage Control/Optimization Algorithms in Active Distribution Network", IEEE Access, 2023
- [54] P. Sarkar, S. Sadanandan, and A. Srivastava, "Resiliency Metrics for Monitoring and Analysis of Cyber-Power Distribution System with IoTs", IEEE Internet of Things Journal, June 2022
- [55] D. Jonathan Sebastian-Cardenas, H. M. Mustafa, A. Hahn, and A. K. Srivastava, "Grid-ViDS: A Smart Grid Co-Simulation Platform for Virtual Device Simulation", Resilience Week, September, 2022
- [56] S. Knudsen, S. Majumder, and A. K. Srivastava, "Securely implementing and managing neighborhood solar with storage and peer to peer transactive energy", 2022 CIGRE Session, Paris, France, August 2022
- [57] A. Gholami, C. Qin, S. Pannala, A. K. Srivastava, "D-PMU Data Generation and Anomaly Detection Using Statistical and Clustering Techniques", 10th Workshop on Modelling and Simulation of Cyber-Physical Energy Systems, May 2022
- [58] A. Acharya, S. Pannala, A. K. Srivastava, and S. R. Bhavirisetty, "Resiliency Planning and Analysis Tool for the Power Grid with Hydro Generation and DERs", North American Power Symposium, Texas A&M University, November, 2021
- [59] A. Vosughi, A. Gholami, A. K. Srivastava, "Denoising and Bad Data Detection in Distribution Phasor Measurements using Filtering, Clustering and Koopman Mode Analysis", IEEE IAS Annual Meeting, October 2021
- [60] M. Mustafa Hussain, D. Wang, K. S. Sajan, E. Nag Pilli, R. Huang, A. K. Srivastava, J. Lian, Z. Huang, "Cyber-Power Co-Simulation for End-to-End Synchrophasor Network Analysis and Applications", IEEE SmartGridComm, October 2021.
- [61] V. Venkataramanan, A. Hahn, A. K. Srivastava, "CP-SAM: Cyber-Physical Security Assessment Metric for Monitoring Microgrid Resiliency", IEEE Transactions on Smart Grid 11(2), pp. 1055-1065, 2019.
- [62] V. Venkataramanan, A. K. Srivastava, A. Hahn, "CyPhyR: A Cyber-Physical Analysis Tool for Measuring and Enabling Resiliency in Microgrids", IET Cyber-Physical Systems: Theory & Applications, vol. 4, no. 4, pp. 313-321, December 2019
- [63] Karngala, Arun Kumar, and Chanan Singh. "Impact of system variables and geo-spatial parameters on the reliability of residential systems with PV and Energy storage" IEEE Access
- [64] Haider, R., D'Achiardi, D., Venkataramanan, V., Srivastava, A., Bose, A., & Annaswamy, A. M. (2021). Reinventing the utility for distributed energy resources: A proposal for retail electricity markets. *Advances in Applied Energy*, 2, 100026.
- [65] R. Haider, S. Baros, Y. Wasa, J. Romvary, K. Uchida and A. M. Annaswamy, "Toward a Retail Market for Distribution Grids," in IEEE Transactions on Smart Grid, vol. 11, no. 6, pp. 4891-4905, Nov. 2020, doi: 10.1109/TSG.2020.2996565.
- [66] Familia, Thomas and Horne, Christine. 2022. "Customer Trust in their Utility Company and Interest in Household-Level Battery Storage." *Applied Energy*. <https://doi.org/10.1016/j.apenergy.2022.119772>
- [67] Horne, Christine, Emily Huddart Kennedy, and Thomas Familia. 2022. "California Consumers' Beliefs and Trust in Electric Utilities." *Socius*. <https://doi.org/10.1177/23780231221105708>
- [68] Horne, Christine and Thomas Familia. 2021. "Norms, Norm Sets, and Reference Groups: Implications for Household Interest in Energy Technologies." *Socius*. <https://doi.org/10.1177/23780231211039035>
- [69] R. Khan, M. Nasir, and N.N. Schulz, "An Optimal Neighborhood Energy Sharing scheme applied to Islanded DC Microgrids for Cooperative Rural Electrification," submitted (IEEE Transactions on Sustainable Energy)
- [70] Khan, Rabia, Noel N. Schulz, and Mashood Nasir "An Optimal Neighbourhood Energy Sharing Scheme Applied to Islanded DC Microgrids for Cooperative Rural Electrification." In IEEE ACCESS Journal 2023, PP 1-8 (under review).
- [71] Khan, Rabia, and Noel N. Schulz. "Power-Electronic Loss Modeling and Analysis of DC Microgrids for Rural Electrification." In 2023 IEEE Global Humanitarian Technology Conference (GHTC), pp. 1-8. IEEE, 2023 (submitted)
- [72] S. Konar, A. Srivastava, "Look-Ahead Corrective Restoration for Microgrids with Flexible Boundary," NAPS 2021.



- [73] S. Konar, A. K. Srivastava, A. Dubey, "Distributed Optimization for Autonomous Restoration in DER-rich Distribution System", IEEE Transactions on Power Delivery (2023).
- [74] C. Wertz et al., "Renewable Energy Resources Connected Utility Microgrid for the Tulalip Tribes," 2022 North American Power Symposium (NAPS), Salt Lake City, UT, USA, 2022, pp. 1-6, doi: 10.1109/NAPS56150.2022.10012187.
- [75] S. Konar and A. K. Srivastava, "MPC-Based Black Start and Restoration for Resilient DER-Rich Electric Distribution System," in IEEE Access, vol. 11, pp. 69177-69189, 2023, doi: 10.1109/ACCESS.2023.3292254.
- [8] M. Kezunovic, R. Baembitov, M. Khoshjahan, T. Mohamed, "Use of ML and AI for automated outage prediction and risk management for improved system resilience," 2023 CIGRE Carins International Symposium, Cairns, Australia, September 2023.
- [9] A. Khan, S. Pannala, and N. Schulz, "Regional Energy Arbitrage With Electric Vehicles Mobility Using Voltage-Cost Curve" IEEE KPEC 2023, April 27-28, PP 1-6.
- [10] Chanda, S., Agalgaonkar, Y., Pannala, S., & Hovsopian, R. (2023, March 23). Validation of Microgrid Algorithms using At-Scale Simulation and Emulation Real-Time (ASSERT) Framework. Proceedings of 13th International Symposium on Advanced Topics in Electrical Engineering., Bucharest, Romania.

---

## Conference Papers - US

- [1] G. Ferro, M. Robba, F. Delfino, R. Haider, and A.M. Annaswamy, "Distributed energy management systems for microgrids: a second order dual update approach." Control Engineering Practice
- [2] M. Khoshjahan and M. Kezunovic, "Analysis of the nano-Grid ancillary service delivery impacts on power grid using real-time simulators," IEEE PowerAfrica Conference
- [3] P.S. Sarker, S. Majumder, Md F. Rafy, A. Srivastava, "Impact Analysis of Cyber-Events on Distributed Voltage Control with Active Power Curtailment" PEDES'22
- [4] R. Haider and A.M. Annaswamy, "A hierarchical coordination approach for voltage regulation in a DER-rich grid edge." 7th IEEE Conference on Control Technology and Applications, 2023
- [5] J.I. Cisneros, M. M. Begovic, "Synchrophasor-Based Relays for Microgrid Protection: Advancements and Applications ", 2023 Hawaii International Conference on System Sciences (HICSS)
- [6] G. Ferro, M. Robba, F. Delfino, R. Haider, A.M. Annaswamy, "Distributed operational management of microgrids: a second order dual update approach," IFAC World Congress 2023 (to appear)
- [7] A. Potter, R. Haider, G. Ferro, M. Robba, A.M. Annaswamy, "A reactive power market for the future grid," ADAPEN 2023. Available here: <https://www.sciencedirect.com/science/article/pii/S266792422000324>
- [11] M. Kezunovic, R. Baembitov, M. Khoshjahan, "Data-driven State of Risk Prediction and Mitigation in Support of the Net-zero Carbon Electric Grid," 2022 IREP Bulk Power System Dynamics and Control Symposium, Banff, Canada.
- [12] S Jena, NP Padhy, A Srivastava, "Resilient Economical Operation of DC Microgrid Clusters with Heterogeneous Sources", IEEE 10th Power India International Conference (PIICON), 2022
- [13] M. Kezunovic, R. Baembitov, M. Khoshjahan, "Towards the Net-zero Carbon Electric Grid Utilizing Data-driven State of Risk Prediction and Mitigation," 2022 IREP Bulk Power System Dynamics and Control Symposium, Banff, Canada.
- [14] P. S. Sarker, N. Patari, B. Ha, S. Majumder, and A. K. Srivastava, "Cyber-power testbed for analyzing distributed control performance during cyber-events," in Accepted for Proceedings of the 9th Workshop on Modeling and Simulation of Cyber-Physical Energy Systems, ser. MSCPES '22, 2022
- [15] J. I. D. Cisneros-Saldana, S. Samal, H. Singh, M. Begovic and S. R. Samantaray, "Microgrid Protection with Penetration of DERs - A Comprehensive Review," 2022 IEEE Texas Power and Energy Conference (TPEC), 2022, pp. 1-6, doi: 10.1109/TPEC54980.2022.9750716.
- [16] R. Haider, G. Ferro, M. Robba and A. M. Annaswamy, "Flattening the Duck Curve: A Case for Distributed Decision Making," 2022 IEEE Power & Energy Society General Meeting (PESGM), Denver, CO, USA, 2022, pp. 01-05, doi: 10.1109/PESGM48719.2022.9917019.



- [17] M. Khoshjahan, and M. Kezunovic, "Cybersecurity Analysis of Prosumer/Aggregator Communications Via Software Defined Networking Emulators," CIREN Workshop on E-mobility and power distribution systems, Porto, Portugal, June 2022.
- [18] M. Kezunovic, M. Khoshjahan, and M. Soleimani, "The Future Role of Active Distribution Load in Enhancing Reliability, Resilience and Security of the Electricity Grids," CIGRE Symposium: Power System Transformation including Active Distribution, Kyoto, Japan, April 2022.
- [19] M. Khoshjahan, M. Kezunovic, "Blockchain Implementation for DER Visibility and Transaction Verification in Wholesale Market," IEEE T&D Conference, New Orleans, USA, April 2022
- [20] R. Haider, R. Jaddivada, A.M. Annaswamy, and M. D. Ilic. "Distributed Backward/Forward Sweep algorithm for economic dispatch in modern distribution grids." In North American Power Symposium, 2021. doi: 10.1109/NAPS50074.2021.9449801
- [21] M. Khoshjahan, R. Baembitov and M. Kezunovic, "Impacts of Weather-Related Outages on DER participation in the Wholesale Market Energy and Ancillary Services," 2021 CIGRE Grid of the Future Symposium, Providence, RI, October 2021.
- [22] A. Asmita, S. Pannala, A. Srivastava and S. R. Bhavarisetty "Resiliency Planning and Analysis Tool for the Power Grid with Hydro Generation and DERs" NAPS 2021, PP 1–6
- [23] M. Kezunovic, M. Khoshjahan and M. Soleimani, "Harvesting the Nano-Grid Flexibility" 2021 CIGRE Grid of the Future Symposium, Providence, Rhode Island, USA, October 2021.
- [24] S. Shrestha, R. Haider, and A.M. Annaswamy. "FERC Order 2222 – What does it mean for DERs?" In IEEE Smart Grid Newsletter, October 2021.
- [25] M. Soleimani, M. Khoshjahan, M. Kezunovic, "Risk-Based Residential Demand Side Response," CIREN 2021 Conference, Geneva, Switzerland, 20-23 September 2021.[Accepted]
- [26] M. Soleimani, M. Khoshjahan, M. Kezunovic, "Reducing Probability of Transformer Failure by Managing EV Charging in Residential Parking Lots," IEEE PES General Meeting, Washington, D.C., 26-29 July, 2021.[Accepted]
- [27] Mohammad Khoshjahan, Milad Soleimani and Mladen Kezunovic, "Tracing and Securing DER Transactions in the Wholesale Electricity Market using Blockchain," IEEE PowerTech conference, Madrid, Spain, 28 June-2 July, 2021 [Accepted]
- [28] Noorazar H, Srivastava A, Pannala S, K Sadanandan S. Data-driven operation of the resilient electric grid: A case of COVID-19. J Eng (Stevenage). 2021 Aug 9:10.1049/tje2.12065. doi: 10.1049/tje2.12065.
- [29] Srayashi Konar, and A. K. Srivastava, "Energy Management and Control of Networked AC-DC Microgrids to Enhance Resiliency", 52nd Annual North American Power Symposium (NAPS), Tempe, Arizona, USA, 11-13 April, 2021 [Accepted]
- [30] Amir Gholami, Anurag K. Srivastava, "Comparative Analysis of ML Techniques for Data-Driven Anomaly Detection, Classification and Localization in Distribution System", 52nd Annual North American Power Symposium (NAPS), Tempe, Arizona, USA, 11-13 April, 2021.
- [31] Khan R, N.N. Schulz, "Network Loss Analysis of Low-Voltage Low-Power DC Microgrids for Rural Electrification", 2020 IEEE/PES Transmission and Distribution Conference and Exposition (T&D) Chicago, IL.
- [32] M. B. Bah, R. Haider, V. Venkataramanan, and A.M. Annaswamy, "Towards a Service-Oriented Broker architecture for the distribution grid," Smart Grids Comm 2020. doi: 10.1109/SmartGridComm47815.2020.9303011
- [33] Anshuman, G. Kandaperumal, J. Linli, S. Pannala and A. Srivastava, "RT-RMS: A Real-Time Resiliency Management System for Operational Decision Support," 2020 52nd North American Power Symposium (NAPS), 2021, pp. 1-6, doi: 10.1109/NAPS50074.2021.9449735.
- [34] P. S. Sarker, A. Singh Saini, K. S. Sajan and A. K. Srivastava, "CP-SAM: Cyber-Power Security Assessment and Resiliency Analysis Tool for Distribution System," 2020 Resilience Week (RWS), 2020, pp. 188-193, doi: 10.1109/RWS50334.2020.9241297.
- [35] Niloy Patari, Anurag Srivastava, Guannan Qu, Na Li, "Distributed Optimal Voltage Control for Three Phase Unbalanced Distribution Systems with DERs", IEEE IAS Annual Meeting, Detroit, Michigan, USA, 11-15 October 2020.

- [36] M. Khoshjahan, M. Soleimani and M. Kezunovic, "Optimal participation of PEV charging stations integrated with smart buildings in the wholesale energy and reserve markets," IEEE ISGT 2020, Washington, DC.
- [37] H. Ren, N. N. Schulz, A Clustering-based Microgrid Planning for Resilient Restoration in Power Distribution System, IEEE PES T&D conference 2020
- [38] Pramila S. Nirbhavane, Leslie Corson, Syed M. Hur Rizvi, and Anurag K. Srivastava, "TPCPF: A Three Phase Continuation Power Flow for Voltage Stability Analysis of the Distribution Systems with DERs", IEEE IAS Annual Meeting, Detroit, Michigan, USA, 11-15 October 2020.
- [39] M. Khoshjahan, M. Soleimani and M. Kezunovic, "Flexibility Provision by Distributed Prosumers in Wholesale Electricity Market," IET CIRED Workshop, Berlin, Germany, September 2020.
- [40] Rabab Haider and A.M. Annaswamy, "Optimal Coordination of Distributed Energy Resources in Smart Grids Enabled by Distributed Optimization." In 2020 MIT A+B Applied Energy Symposium Going Virtual, 13-14 August, 2020.
- [41] Ahmed Yousuf Saber, Tanuj Khandelwal, Anurag K Srivastava, and Tilottoma Barua "Hyper Deep Learning based Load Forecasting" IEEE Power & Energy Society General Meeting (PESGM), to be held in Montreal, Canada, during 3-6 August, 2020. 2020.
- [42] A.Y. Saber "Research and Education in Distribution Management System with DERs for Resilient Grid," IEEE Power & Energy Society General Meeting (PESGM), to be held in Montreal, Canada, during 3-6 August, 2020.
- [43] G. Ferro, M. Robba, D. D'Achiardi, R. Haider, and A.M. Annaswamy. "A Distributed Approach to the Optimal Power Flow Problem for Unbalanced and Mesh Networks." In 21st IFAC World Congress, 12-17 July 2020.
- [44] M. Soleimani, M. Kezunovic, "Economic Analysis of Transformer Loss of Life Mitigation Using Energy Storage and PV Generation," 2020 IEEE/PES Transmission and Distribution Conference and Exposition (T&D), Chicago, Illinois, April, 2020.
- [45] P. S. Sarker, V. Venkataramanan, D. S. Cardenas, A. Srivastava, A. Hahn and B. Miller, "Cyber-Physical Security and Resiliency Analysis Testbed for Critical Microgrids with IEEE 2030.5," 2020 8th Workshop on Modeling and Simulation of Cyber-Physical Energy Systems, Sydney, Australia, 2020
- [46] A. Karaki, M. Begovic, S. Bayhan and H. Abu-Rub, "Frequency and Voltage Restoration for Droop Controlled AC Microgrids," 2019 2nd International Conference on Smart Grid and Renewable Energy (SGRE), Doha, Qatar, 2019, pp. 1-6, doi: 10.1109/SGRE46976.2019.9020914.
- [47] R. Haider, A.M. Annaswamy, D. D'Achiardi, A. Srivastava, A. Bose, "A Proposal for a DSO Centric Retail Electricity Market," Whitepaper, 2019
- [48] Rabia Khan, Noel N. Schulz and Mashood Nasir, "Distribution Loss Analysis of DC Microgrids for Rural Electrification," IEEE Global Humanitarian Technology Conference (GHTC), 17-20 October, 2019
- [49] V. Venkataramanan, P. S. Sarker, K. S. Sajan, A. Srivastava, and A. Hahn, "A Real-Time Transmission-Distribution Testbed for Resiliency Analysis", IEEE Industrial Application Society Annual Meeting, Baltimore, MD, 29 Sept.-3 Oct. 2019
- [50] M. Soleimani, M. Kezunovic, "Economic Evaluation of Transformer Loss of Life Mitigation by Energy Storage and PV Generation," 13th International Conference on Deregulated Electricity Market Issues in South Eastern Europe (DEMSEE), September, 2019.
- [51] M. Soleimani, C. Affonso, M. Kezunovic, "Transformer Loss of Life Mitigation in the Presence of Energy Storage and PV Generation," 2019 IEEE PES Innovative Smart Grid Technologies Conference Europe (ISGT-Europe), Bucharest, Romania, September, 2019. DOI: 10.1109/ISGTEurope.2019.8905763 .
- [52] S. Pandey, N. Patari, A. Srivastava, "Cognitive Flexibility of Power Grid Operator and Decision Making in Extreme Events", IEEE PES General Meeting, Atlanta, GA, 4-8 August 2019. DOI: 10.1109/PESGM40551.2019.8974015
- [53] A. Saber, A. Srivastava, "Renewable Hosting Capacity", IEEE PES General Meeting, Atlanta, GA, 4-8 August 2019.
- [54] Anuradha Annaswamy, "Integration of Disitributed Enegy Resources in Retail Markets", IEEE PES ISGT 15-18 September, 2019 (also presented at University of Notre Dameon)
- [55] Ahmed Y Saber ; Anurag K Srivastava, "Fast Feeder PV Hosting Capacity using Swarm Based Intelligent Distribution Node Selection" ,IEEE PES General Meeting, Atlanta, GA, 4-8 August 2019. DOI: 10.1109/PESGM40551.2019.8973389



- [56] Mohammad Hossein Namaki, Qi Song, Yinghui Wu, and Shengqi Yang, “Answering Why-questions by Exemplars in Attributed Graphs” published in SIGMOD 2019 International Conference on Management of Data June 2019 Pages 1481–1498. DOI: doi.org/10.1145/3299869.3319890
- [57] D. Jonathan Sebastian, Adam Hahn, “IoT Threats to the Smart Grid: A Framework for Analyzing Emerging Risks”, Northwest Cybersecurity Symposium. Richland, WA. 8-10 April 2019.
- [58] Yue Zhang, Scott Eiseley, Abhishek Dubey, Aron Laszka, Anurag K. Srivastava, “Cyber-Physical Simulation Platform for Security Assessment of Transactive Energy Systems”, MSCPES Workshop, CPS Week, Montreal, March 2019
- [59] A. Karaki, M.Begovic, H. AbuRub, S. Bayhan, I. Poonahela, “On Frequency Control Techniques for Microgrids”, Proceedings 2018 IEEE SEST Conference, Sevilla, Spain, September 2018. DOI: 10.1109/SEST.2018.8495812
- [60] M. Begovic, “Photovoltaics and Smart Grid Integration of Renewables,” Proceedings of the 2018 International Conference on Energy and Ecology Industry, Belgrade, October 2018.
- [61] S. Zhao, C. Singh, “Using Contingency Ranking Method in Reliability Evaluation of Line Switching Operation”, 2018 IEEE PES T&D Latin America Conference, Lima, Peru, September, 2018. DOI: 10.1109/TDC-LA.2018.8511705
- [62] Ahmed Saber and AKM Rezaul Alam, “Short Term Load Forecasting using Multiple Linear Regression for Big Data,” IEEE SSCI 2017, Nov 27 to Dec 1, 2017 Hawaii, USA. DOI: 10.1109/SSCI.2017.8285261





## Standards

- [1] IEEE Standard for Interconnection and Interoperability of Distributed Energy Resources with Associated Electric Power Systems Interfaces. IEEE 1547-2018, April 2018.
- [2] IEEE Standard Conformance Test Procedures for Equipment Interconnecting Distributed Energy Resources with Electric Power Systems and Associated Interfaces, IEEE Std 1547.1-2020, May 2020.
- [3] IEEE Application Guide for IEEE Std 1547(TM), IEEE Standard for Interconnecting Distributed Resources with Electric Power Systems, IEEE Std 1547.2-2008, April 2009.
- [4] IEEE Guide for Monitoring, Information Exchange, and Control of Distributed Resources Interconnected with Electric Power Systems, IEEE Std 1547.3-2007, Nov. 2007.
- [5] IEEE Guide for Design, Operation, and Integration of Distributed Resource Island Systems with Electric Power Systems, IEEE Std 1547.4-2011, July 2011.
- [6] IEEE Recommended Practice for Interconnecting Distributed Resources with Electric Power Systems Distribution Secondary Networks, IEEE Std 1547.6-2011, Sept. 2011.
- [7] IEEE Approved Draft Guide to Conducting Distribution Impact Studies for Distributed Resource Interconnection, IEEE P1547.7/D11, June 2013, Feb. 2014.
- [8] IEEE Draft Recommended Practice for Establishing Methods and Procedures that Provide Supplemental Support for Implementation Strategies for Expanded Use of IEEE Standard 1547, IEEE P1547.8/D8, Jan. 2014.
- [9] IEEE Guide for Using IEEE Std 1547 for Interconnection of Energy Storage Distributed Energy Resources with Electric Power Systems, IEEE Std 1547.9-2022, Aug. 2022.
- [10] IEEE Standard Cybersecurity Requirements for Substation Automation, Protection, and Control Systems, IEEE Std C37.240-2014, Jan. 2015.
- [11] Power systems management and associated information exchange - Data and communications security - ALL PARTS, IEC 62351:2023 SER series, 2023.
- [12] Guidelines to Smart Grid Cybersecurity, NISTIR 7628, 2010.
- [13] IEEE Guide for Design, Operation, and Maintenance of Battery Energy Storage Systems, both Stationary and Mobile, and Applications Integrated with Electric Power Systems, IEEE Std 2030.2.1-2019, Dec. 2019.
- [14] IEEE Recommended Practice for the Characterization and Evaluation of Energy Storage Technologies in Stationary Applications, IEEE Std 1679-2020 (Revision of IEEE Std 1679-2010), April 2020.
- [15] IEEE Recommended Practice for Performance Testing of Electrical Energy Storage (EES) System in Electric Charging Stations in Combination with Photovoltaic (PV), IEEE Std 2836-2021, June 2021.
- [16] NIST Framework and Roadmap for Smart Grid Interoperability Standards, Release 1.0, NIST Special Publication 1108, 2010.
- [17] IEEE Std 2030-2011 Guide for Smart Grid Interoperability of Energy Technology and Information Technology Operation with the Electric Power System (EPS), and End-Use Applications and Loads, 2011.
- [18] IEEE Standard for Technical Specifications of a DC Quick and Bidirectional Charger for Use with Electric Vehicles - Redline, IEEE Std 2030.1.1-2021 (Revision of IEEE Std 2030.1.1-2015), Feb. 2022.
- [19] IEEE Guide for the Interoperability of Energy Storage Systems Integrated with the Electric Power Infrastructure, IEEE Std 2030.2-2015, June 2015.
- [20] IEEE Guide for Design, Operation, and Maintenance of Battery Energy Storage Systems, both Stationary and Mobile, and Applications Integrated with Electric Power Systems, IEEE Std 2030.2.1-2019, Dec. 2019.
- [21] IEEE Standard Test Procedures for Electric Energy Storage Equipment and Systems for Electric Power Systems Applications, IEEE Std 2030.3-2016, Sept. 2016.
- [22] IEEE Standard for Smart Energy Profile Application Protocol, IEEE Std 2030.5-2018 (Revision of IEEE Std 2030.5-2013), Dec. 2018.
- [23] IEEE Guide for the Benefit Evaluation of Electric Power Grid Customer Demand Response, IEEE Std 2030.6-2016, Dec. 2016.

- [24] IEEE Standard for the Specification of Microgrid Controllers, IEEE Std 2030.7-2017, April 2018.
- [25] IEEE Standard for the Testing of Microgrid Controllers, IEEE Std 2030.8-2018, Aug. 2018.
- [26] IEEE Recommended Practice for the Planning and Design of the Microgrid, IEEE Std 2030.9-2019, July 2019.
- [27] IEEE Guide for Distributed Energy Resources Management Systems (DERMS) Functional Specification, IEEE Std 2030.11-2021, June 2021.
- [28] IEEE Recommended Practice for Implementing an IEC 61850-Based Substation Communications, Protection, Monitoring, and Control System, IEEE Std 2030.100-2017, June 2017.
- [29] IEEE Standard for Interoperability of Internet Protocol Security (IPsec) Utilized within Utility Control Systems, IEEE Std 2030.102.1-2020, March 2021.
- [30] IEEE Standard for DC Microgrids for Rural and Remote Electricity Access Applications, IEEE Std 2030.10-2021, Dec. 2021.
- [31] Microgrids - Part 1: Guidelines for microgrid projects planning and specification, IEC TS 62898-1:2017, 2017.
- [32] Microgrids - Part 2: Guidelines for operation, IEC TS 62898-2:2018, 2018.
- [33] Microgrids - Part 3-1: Technical requirements - Protection and dynamic control, IEC TS 62898-3-1:2020, 2020.
- [34] Microgrids - Part 3-3: Technical requirements - Self-regulation of dispatchable loads, IEC TS 62898-3-3:2023, 2023.
- [35] Microgrids - Part 3-4: Technical requirements - Microgrid monitoring and control systems, IEC TS 62898-3-4:2023, 2023.
- [36] Microgrids - Part 4: Use cases, IEC TR 62898-4:2023, 2023.
- [37] Assessment of power quality – Characteristics of electricity supplied by public Networks, IEC TS 62749, Feb. 2020.
- [38] Distributed energy resources connection with the grid, IEC TS 62786, Mar. 2017.
- [39] Assessment of power quality – Characteristics of electricity supplied by public networks, IEC TS 62749, Feb. 2020.
- [40] Communication networks and systems for power utility automation - ALL PARTS, IEC 61850:2023 SER series, Aug. 2023.
- [41] IEEE Standard for Synchrophasor Measurements for Power Systems, IEEE Std C37.118.1-2011 (Revision of IEEE Std C37.118-2005), Dec. 2011.
- [42] IEEE Guide for Safety in AC Substation Grounding, IEEE Std 80-2000, Aug. 2000.
- [43] IEEE Guide for Instrumentation and Control Equipment Grounding in Generating Stations, IEEE Std 1050-2004 (Revision of IEEE Std 1050-1996), Sept. 2005.
- [44] IEEE Guide for Direct Lightning Stroke Shielding of Substations, IEEE Std 998-2012 (Revision of IEEE Std 998-1996), April 2013.
- [45] IEC/IEEE International Standard - Power transformers - Part 16: Transformers for wind turbine applications, IEC/IEEE 60076-16 Edition 2.0 2018-09, Sept. 2018.
- [46] Electromagnetic compatibility (EMC) – Part 4-30: Testing and measurement techniques – Power quality measurement methods, IEC 61000-4-30, 2015.
- [47] Electricity metering equipment (a.c.) – Particular requirements – Part 22: Static meters for active energy (classes 0,2 S and 0,5 S), IEC 62053-22, 2003.
- [48] Electricity metering equipment - Particular requirements - Part 23: Static meters for reactive energy (classes 2 and 3), IEC 62053-23:2020, 2020.
- [49] Telecontrol equipment and systems - Part 5-7: Transmission protocols - Security extensions to IEC 60870-5-101 and IEC 60870-5-104 protocols (applying IEC 62351), IEC TS 60870-5-7:2013, 2013.
- [50] Photovoltaic (PV) Systems - Characteristics of the Utility Interface, IEC 61727-2004, 2004.
- [51] Recommended Practice for Utility Interface of Photovoltaic Systems, IEEE Std 929-2000, 2000.
- [52] IEEE Recommended Practice for Monitoring Electric Power Quality, IEEE Std. 1159-1995, 1995.
- [53] Standard for Smart Energy Profile 2.0 Application Protocol, I. S. 2030.5-2013, 2013.
- [54] IEEE Standard for Harmonic Control in Electric Power Systems, IEEE Std 519-2022 (Revision of IEEE Std 519-2014), Aug. 2022.



- [55] Electrical Installations of Buildings - Part 7-712: Requirements for Special Installations or Locations - Solar Photovoltaic (PV) Power Supply Systems, International Electrotechnical Commission (IEC), IEC 60364-7-712-2002, 2002.
- [56] Grid Connection of Energy Systems via Inverters Part 1: Installation Requirements, Council of Standards Australia, AS 4777.1-2005, 2005.
- [57] Grid Connection of Energy Systems via Inverters Part 2: Inverter Requirements, Council of Standards Australia, AS 4777.2-2005, 2005.
- [58] Grid Connection of Energy Systems via Inverters Part 3: Grid Protection Requirements, Council of Standards Australia, AS 4777.3-2005, 2005.
- [59] Interconnecting Inverter-Based Micro-Distributed Resources to Distribution Systems, Canadian Standards Association (CSA), CAN/CSA-C22.2 No. 257-06-R2015, 2015.
- [60] Interconnection of Distributed Resources and Electricity Supply Systems, Canadian Standards Association (CSA), CSA C22.3 No. 9-08-R2015, 2015.
- [68] MPERC, “Micro-Grid Renewable Energy Generation and Supply Regulations,” 2016. [Online]. Available: [Draft Mini-Grid Renewable Energy Generation and Supply Regulations, 2016 \(mperc.in\)](#).
- [69] J&KSERC, “Mini Grid Renewable Energy Generation and Supply Regulations,” 2016. [Online]. Available: [Microsoft Word - JKSERC Mini Grid Renewable Energy Generation and Supply Regulations 2016 19.12.2016 Final \(cbip.org\)](#).
- [70] AERC, “Micro/Minigrid Renewable Energy Generation and Supply Regulations,” 2018. [Online]. Available: [1671255640.pdf \(aerc.gov.in\)](#).
- [71] OERC, “Mini-grid Renewable Energy Generation & Supply Regulations,” 2019. [Online]. Available: [Full page photo \(oriarc.org\)](#).
- [72] “Power Generation Systems Connected to the Low-Voltage Distribution Network - Technical Minimum Requirements for the Connection to and Parallel Operation With Low-Voltage Distribution Networks,” VDE-ARN 4105-2011, 2011.
- [73] “Rule 21 Generating Facility Interconnections”, California Public Utilities Commission (CPUC), San Francisco, CA, USA, 2014.

---

## Grid Codes and Regulations

- [61] Central Electricity Authority (CEA), “Technical Standards for Connectivity to the Grid,” 2007.
- [62] CEA, “Technical Standards for Connectivity to the Grid (Amendment),” 2013.
- [63] CEA, “Technical Standards for Connectivity to the Grid (Amendment),” 2019.
- [64] CERC, "Draft Indian Electricity Grid Code Regulations, 2022," June 2022. [Online]. Available: [https://cercind.gov.in/2022/draft\\_reg/Draft-IEGC-07062022.pdf](https://cercind.gov.in/2022/draft_reg/Draft-IEGC-07062022.pdf)
- [65] “Model Smart Grid Regulations, Forum of Regulators, 2015”. [Online]. Available: [MODEL SMART GRID REGULATIONS \(forumofregulators.gov.in\)](#)
- [66] BEREC, “Draft Mini Grid Renewable Energy Generation and Supply Framework Regulations,” 2016. [Online]. Available: [draft\\_min\\_grid\\_regulations.pdf \(berc.co.in\)](#)
- [67] UPERC, “Mini-Grid Renewable Energy Generation and Supply Regulations”, 2016.
- [74] “Texas Distributed Generation Interconnection Manual,” Public Utility Commission of Texas (PUCT), 2002.
- [75] “Recommendations for the Connection of Type Tested Small-Scale Embedded Generators (Up to 16A Per Phase) in Parallel with Low-Voltage Distribution Systems,” Energy Networks Association (ENA), Engineering Recommendation G83 Issue 2-2012, 2012.
- [76] “Automatic Disconnection Device Between a Generator and the Public Low-Voltage Grid,” German Commission for Electrical, Electronic & Information Technologies (DKE), DIN V VDE V 0126-1-1 (VDE V 0126-1-1)-2013, 2013.
- [77] RD 1663/2000 “Royal Decree Establishing Basic Administrative and Technical Conditions of Connection to the Low Voltage Network of Solar Photovoltaic,” 2000.
- [78] “Technical Requirements for Grid Connection of PV System”, Standardization Administration of the P.R.C., GB/T 19939-2005, 2005.
- [79] “Technical Requirements for Connecting Photovoltaic Power Station to Power System,” Standardization Administration of the P.R.C., GB/T 19964-2012, 2012.

- [80] “Photovoltaic (PV) Systems - Characteristics of the Utility Interface,” Standardization Administration of the P.R.C., GB/T 20046-2006, 2006.
- [81] “Photovoltaic (PV) Systems - Characteristics of the Utility Interface,” Chinese National Standards (CNS), CNS 15382-2010, 2010.
- [82] “Taiwan Power Company Technical Guideline for Integrating Renewable Energy with the Grid,” Taiwan Power Company (TPC), 2009.
- [83] “Technical Guideline for Integrating Distributed Resources with the Grid,” Korea Electric Power Corporation (KEPCO), 2007.
- [84] “Grid-Interconnection Code,” The Japan Electric Association, JEAC 9701-2012, 2012.
- [85] “The Grid Operation Code,” Standardization Administration of the P.R.C., DL/T1040-2007, 2007.
- [86] “Technical Specification of Grid-Connected PV Inverter,” Standardization Administration of the P.R.C., NB/T 32004-2013, 2013.
- [87] Energinet/DK, “Technical regulation 3.2.2 for PV power plants with a power output above 11 kW,” 2015.
- [88] “Reference Technical Rules for the Connection of Active and Passive Users to the LV Electrical Utilities,” CEI Standard Number 0-21, 2012.
- [93] Ministry of New and Renewable Energy, “Guidelines on implementation of Phase – II of Grid Connected Rooftop Solar Program for achieving 40 GW capacity from Rooftop Solar by the year 2022,” August 2019. [Online]. Available: <https://mnre.gov.in/img/documents/uploads/7ccd3b4b3bb94a51af516e2ee4fdede3.pdf>
- [94] Staff Paper on “Introduction of Electricity Storage System in India,” CERC, 2017. [Online]. Available: [https://cercind.gov.in/2017/draft\\_reg/SP.pdf](https://cercind.gov.in/2017/draft_reg/SP.pdf).
- [95] “National Wind-solar Hybrid policy,” MNRE, 2018. [Online]. Available: <https://mnre.gov.in/img/documents/uploads/2775b59919174bb7aeb00bb1d5cd269c.pdf>.
- [96] “Flexible Operation of Thermal Power Plant for Integration of Renewable Generation,” [Online]. Available: [https://cea.nic.in/wp-content/uploads/2020/04/flexible\\_operation.pdf](https://cea.nic.in/wp-content/uploads/2020/04/flexible_operation.pdf)
- [97] “National Energy Storage Mission, Niti Aayog, 2020.” [Online]. Available: <https://eamrit.niti.gov.in/assets/admin/dist/img/new-frontend-img/report-pdf/India-Energy-Storage-Mission.pdf>.
- [98] “Report on Intra state Reserves and Ancillary services for Balancing (SANTULAN),” CERC, 2020. [Online]. Available: <http://forumofregulators.gov.in/Data/Reports/SANTULAN-FOR-Report-April2020.pdf>
- [99] “Regulatory Framework for Energy Storage and Electric Vehicles, Forum of Regulators, 2022.” [Online]. Available: <https://forumofregulators.gov.in/Data/study/FO R-Report-Framework-Energy-Storage and EV.pdf>.

## Policy Documents and Guidelines

- [89] “The Electricity Act, 2003,” [Online]. Available: <https://cercind.gov.in/Act-with-amendment.pdf>.
- [90] Ministry of Power, “Draft National Electricity Policy,” 27 April 2021. [Online]. Available: [https://powermin.gov.in/sites/default/files/Inviting\\_suggestions\\_on\\_draft\\_NEP\\_2021\\_0.pdf](https://powermin.gov.in/sites/default/files/Inviting_suggestions_on_draft_NEP_2021_0.pdf)
- [91] “National Framework for Promoting Energy Storage Systems,” Government of India Ministry of Power, August 2023.
- [92] Ministry of New and Renewable Energy, “Guidelines on implementation of Phase – II of Grid Connected Rooftop Solar Program for achieving 40 GW capacity from Rooftop Solar by the year 2022,” August 2019. [Online]. Available: <https://mnre.gov.in/img/documents/uploads/7ccd3b4b3bb94a51af516e2ee4fdede3.pdf>
- [100] “Optimal Generation Capacity mix for 2029-30,” CEA, 2023. [Online]. Available: [https://cea.nic.in/wp-content/uploads/irp/2020/12/Optimal\\_mix\\_report\\_2029-30\\_FINAL.pdf](https://cea.nic.in/wp-content/uploads/irp/2020/12/Optimal_mix_report_2029-30_FINAL.pdf)
- [101] “Draft Standard Bidding Documents for Privatization of Distribution Licensees,” Ministry of Power, New Delhi, 2020.
- [102] “Ancillary Services Regulations, 2021,” Central Electricity Regulatory Commission, 2021.
- [103] CERC Staff, “Developing a Common Platform for Electricity Trading,” [Online]. Available: <https://cercind.gov.in/03022007/Commonplatformforelectricitytrading.pdf>.



- [104] “TRANSFORMING THE INDIAN POWER SECTOR: Need, Frameworks, and Regulatory Considerations Distribution System Operators (DSOs),” Department of Science and Technology, Government of India, 2023.
- [105] “Amendments to the Guidelines for Tariff Based Competitive Bidding Process for Procurement of Round-The Clock Power from Grid Connected Renewable Energy Power Projects, complemented with Power from any other source or storage,” Ministry of Power, Government of India, August 2022. [Online]. Available: [https://powermin.gov.in/sites/default/files/Amendments\\_to\\_the\\_Guidelines\\_for\\_Tariff\\_Based\\_Competitive\\_Bidding\\_1.pdf](https://powermin.gov.in/sites/default/files/Amendments_to_the_Guidelines_for_Tariff_Based_Competitive_Bidding_1.pdf)
- [106] “Guidelines for Procurement and Utilization of Battery Energy Storage Systems as part of Generation, Transmission and Distribution assets, along with Ancillary Services, Ministry of Power, Government of India,” March 2022. [Online]. Available: [1 Guidelines for Procurement and Utilization of Battery Energy Storage Systems dtd 10.03 2022.pdf](https://powermin.gov.in/sites/default/files/Procurement_and_Utilization_of_Battery_Energy_Storage_Systems_dtd_10.03_2022.pdf) ([powermin.gov.in](https://powermin.gov.in)).
- [107] “Renewable Purchase Obligation (RPO) and Energy Storage Obligation Trajectory till 2029-30 – regarding, Ministry of Power, Government of India,” July 2022. [Online]. Available: [https://powermin.gov.in/sites/default/files/Renewable\\_Purchase\\_Obligation\\_and\\_Energy\\_Storage\\_Obligation\\_Trajectory\\_till\\_2029\\_30.pdf](https://powermin.gov.in/sites/default/files/Renewable_Purchase_Obligation_and_Energy_Storage_Obligation_Trajectory_till_2029_30.pdf)
- [108] “National Renewable Energy Act (Draft), MNRE, Government of India,” 2015. [Online]. Available: [68b053c5a944493e813c24a93cb39263.pdf](https://mnre.gov.in/sites/default/files/68b053c5a944493e813c24a93cb39263.pdf) ([mnre.gov.in](https://mnre.gov.in)).
- [109] “Base Paper on Implementation of Tariff Policy 2016, Central Electricity Authority,” May 2017. [Online]. Available: [Base paper on Implementation of Tariff Policy framed on 2016.pdf](https://cea.nic.in/sites/default/files/Base_paper_on_Implementation_of_Tariff_Policy_framed_on_2016.pdf) ([cea.nic.in](https://cea.nic.in)).
- [110] “National Policy for Renewable Energy based Micro and Mini Grids, MNRE, Government of India,” 2016. [Online]. Available: [102-draft-national-Mini-Micro-Grid-Policy.pdf](https://theCLEANNetwork.org/sites/default/files/102-draft-national-Mini-Micro-Grid-Policy.pdf) ([theCLEANNetwork.org](https://theCLEANNetwork.org)).
- [111] “Uttar Pradesh Mini Grid Policy,” 2016. [Online]. Available: [Untitled-1](https://upneda.org.in/sites/default/files/Untitled-1.pdf) ([upneda.org.in](https://upneda.org.in)).
- [112] “Odisha Renewable Energy Policy,” Department of Energy, Government of Odisha, 2022. [Online]. Available: [3354-Energy dept. 1.pdf](https://odisha.gov.in/sites/default/files/3354-Energy_dept_1.pdf) ([odisha.gov.in](https://odisha.gov.in)).
- [113] “Policy for Promotion of New and Renewable Energy Sources, Energy Department, Government of Bihar,” 2017. [Online]. Available: [RENEWABLE ENERGY POLICY 2017.pdf](https://bih.nic.in/sites/default/files/RENEWABLE_ENERGY_POLICY_2017.pdf) ([bih.nic.in](https://bih.nic.in)).
- [114] “Draft National Energy Policy NITI Aayog,” Government of India, 2017. [Online]. Available: [Draft National Energy Policy](https://udyami.org.in/sites/default/files/Draft_National_Energy_Policy.pdf) ([udyami.org.in](https://udyami.org.in)).
- [115] “Jharkhand State Solar Policy 2022,” Department of Energy, Government of Jharkhand, July 2022. [Online]. Available: [6360e972de5e0.pdf](https://jreda.com/sites/default/files/6360e972de5e0.pdf) ([jreda.com](https://jreda.com)).
- [116] “Reliability Guideline Bulk Power System Reliability Perspectives on the Adoption of IEEE 1547-2018,” NERC, March 2023.
- [117] “Coordination of Distributed Energy Resources: International System Architecture Insights for Future Market Design,” Australian Energy Market Operator, Ltd., 2018.
- [118] “Energy Storage and Distributed Energy Resources (ESDER) Stakeholder Initiative,” California ISO, 2015.
- [119] “Distributed Energy Resources Market Design Concept Proposal,” New York Independent System Operator, 2017.
- [120] NERC, “NERC Reliability Guideline on BPS-Connected Inverter-Based Resource Performance,” NERC, Sept. 2018.

---

## Technical Reports and White Papers

- [121] “Microgrids: Utility Challenges and Opportunities,” MicroGrids Whitepaper, IEEE Smart Grid Technical Activities Committee, 2022.
- [122] “Power Sector at a Glance ALL INDIA,” Ministry of Power, 2023. [Online]. Available: [power\\_sector\\_at\\_glance\\_July\\_2023.pdf](https://powermin.gov.in/sites/default/files/power_sector_at_glance_July_2023.pdf) ([powermin.gov.in](https://powermin.gov.in)).
- [123] NERC, “Performance of Distributed Energy Resources During and After System Disturbance: Voltage and Frequency Ride-Through Requirements,” 2013.
- [124] NERC, “Distributed Energy Resources: Connection, Modeling, and Reliability Considerations,” 2017.



- [125] EPRI, “Recommended Settings for Voltage and Frequency Ride-Through of Distributed Energy Resources. Minimum and Advanced Requirements and Settings for the Performance of Distributed Energy Resources During and After System Disturbances to Support Bulk Power System Reliability and Their Respective Technical Implications on Industry Stakeholders, 3002006203,” 2015.
- [126] PJM, “PJM Guideline for Ride Through Performance of Distribution-Connected Generators,” 2019.
- [127] MISO, “IEEE 1547- Distribution Interconnection Coordination”, [Online]. Available: <https://www.misoenergy.org/planning/generator-interconnection/ieee-1547/>.
- [128] EPRI, “Understanding Smart Inverter Functions’ Impact on Islanding Detection. Technical Update. 3002012986,” December 2018.
- [129] Sandia National Laboratory, “Evaluation of Multi-Inverter Anti-Islanding with Grid Support and Ride-Through and Investigation of Island Detection Alternatives. SAND2019-0499,” January 2019.
- [130] EPRI, “DER Modeling Guidelines for Transmission Planning Studies: 2018 Summary. Technical Update,” 2018.
- [131] EPRI, “Current Practices in Scheduling Distributed Energy Resources into System Operations: An Examination of Selected U.S. and International Regions, 3002009483,” 2017.
- [132] EPRI, “Transmission and Distribution Operations and Planning Coordination. TSO/DSO and Tx/Dx Planning Interaction, Processes, and Data Exchange,” 2019.
- [133] EPRI, “Common Functions for DER Group Management: Third Edition, 3002008215,” 2016.
- [134] Sandia National Laboratory, “Unintentional Islanding Detection Performance with Mixed DER Types. SAND2018-8431,” July 2018.
- [135] “DNV-RP-0043 Safety, operation and performance of grid-connected energy storage systems - Recommended practice (Edition 2017-09 - Amended 2021-10),” 2021.
- [136] O. Zinaman, T. Bowen, and A. Aznar, “An overview of behind-the-meter solar-plus-storage regulatory design: Approaches and case studies to inform international applications”, National Renewable Energy Laboratory, March 2020.
- [137] C. Gokhale-Welch and S. Stout, “Key Considerations for Adoption of Technical Codes and Standards for Battery Energy Storage Systems in Thailand,” National Renewable Energy Laboratory, 2021.
- [138] “An Overview of Distributed Energy Resource (DER) Interconnection: Current Practices and Emerging Solutions, National Renewable Energy Laboratory, Tech. Rep. NREL/TP-6A20-72102,” 2019.
- [139] “Guidance No. 1 for the Interconnection of Electric Storage as Stand-Alone Sources, Parallel Operation for Customers without Generation, and in Parallel with Self-Generation, Xcel Energy,” 2017.
- [140] “Handbook on Battery Energy Storage System, Asian Development Bank,” 2018.
- [141] “European White Book on Grid-Connected Storage, DER lab Report No. R- 003.0, European Distributed Energy Resources Laboratories,” 2011.
- [142] “Smart Grid Case Studies - Spotlight on Energy Storage Systems Casebook, ISGAN Annex 2 Smart Grid Case Studies, International Smart Grid Action Network,” March 2019.
- [143] “GREENING THE GRID: Pathways to Integrate 175 Gigawatts of Renewable Energy into India’s Electric Grid, Vol. I – National Study’, USAID and Ministry of Power GOI,” June 2017.
- [144] “Enhancing distribution resiliency: Opportunities for applying innovative technologies,” in Proc. IEEE Elect. Power Res. Inst., Tech. Rep. 026889, 2013.
- [145] BSES Rajdhani, “BSES Commissions Solar Micro Grids with Energy Battery Storage,” March 2019. [Online]. Available: [https://www.bsedelhi.com/documents/73527/626545808/Micro\\_Solar\\_Grid\\_eng.pdf](https://www.bsedelhi.com/documents/73527/626545808/Micro_Solar_Grid_eng.pdf)
- [146] R. Poudineh, M. Mukherjee and G. Elizondo, “The Rise of Distributed Energy Resources: A Case Study of India’s Power Market,” Oxford Institute for Energy Studies, 2021.
- [147] “Global Microgrid Market 2016-2020,” TechNavio, Dublin, Ireland, 2016.
- [148] “Microgrid Controller Standardization, Approach, Benefits and Implementation, Grid of the Future,” CIGRE, 2017.
- [149] Underwriters Laboratories, “UL 1741 Supplement SA: Grid Support Utility Interactive Inverters and Converters,” 2016.

**[150]** J. Paananen and E. Nasr, "Grid-interactive data centers: enabling decarbonization and system stability," Microsoft-Eaton whitepaper, 2021.

**[151]** "Powering Microgrids for the 21st-Century Electrical System," NEMA, 2016.

**[152]** M. Farrokhhabadi et al, "Microgrid Stability Definitions, Analysis, and Examples," IEEE Power and Energy Society, 2018.

**[153]** Net-zero Carbon Microgrid Program, Idaho National Laboratory, "NZM Planning and Design Tool," October 2021.

**[154]** K. P. Schneider et al, "Preliminary Design Process for Networked Microgrids," Pacific Northwest National Laboratory, June 2020.

**[155]** R. Jeffers et al, "A Grid Modernization Approach for Community Resilience: Application to New Orleans, LA," Technical Report, Sandia National Laboratories, Oct. 2007.

---

## Magazine Articles on Smart Distribution Systems and Microgrids

**[156]** M. Amin and S. Wollenberg, "Toward a smart grid: Power delivery for the 21st century," IEEE Power Energy Mag., vol. 3, no. 5, pp. 34-41, Sept.-Oct. 2005.

**[157]** N. Hatziargyriou, H. Asano, R. Iravani and C. Marnay, "Microgrids," IEEE Power Energy Mag., vol. 5, no. 4, pp. 78-94, July 2007.

**[158]** H. Farhangi, "The path of the smart grid," in IEEE Power Energy Mag., vol. 8, no. 1, pp. 18-28, January-February 2010.

**[159]** F. Katiraei, M. R. Iravani, N. Hatziargyriou and A. Dimeas, "Microgrids management," IEEE Power Energy Mag., vol. 6, no. 3, pp. 54-65, May-June 2008.

**[160]** G. Joos, J. Reily, W. Bowe and R. Neal, "Microgrid Controllers, The Need for Standardization," IEEE Power Energy Mag., July/August 2017.

**[161]** M. Arriaga, E. Nasr and H. Rutherford, "Renewable energy microgrids in northern remote communities," IEEE Potentials, vol. 36, pp. 22-29, Sept. 2017.

**[162]** C. Abbey, D. Cornforth, N. Hatziargyriou, K. Hirose, A. Kwasinski, E. Kyriakides, G. Platt, L. Reyes and S. Suryanarayanan, "Powering through the storm: Microgrids operation for more efficient disaster recovery," IEEE Power Energy Mag., vol. 12, no. 3, pp. 67-76, 2014.

**[163]** B. Kroposki, R. Lasseter, T. Ise, S. Morozumi, S. Papathanassiou and N. Hatziargyriou, "Making microgrids work," IEEE Power Energy Mag., vol. 6, no. 3, pp. 40-53, 2008.

**[164]** D. T. Ton and W.-T. P. Wang, "A more resilient grid: The U.S. Department of Energy joins with stakeholders in an R&D plan," IEEE Power Energy Mag., vol. 13, no. 3, pp. 26-34, May/June 2015.

**[165]** X. Fang, S. Misra, G. Xue and D. Yang, "Smart Grid — The New and Improved Power Grid: A Survey," in IEEE Communications Surveys & Tutorials, vol. 14, no. 4, pp. 944-980, Fourth Quarter 2012.

**[166]** J. Fan and S. Borlase, "The evolution of distribution," IEEE Power Energy Mag., vol. 7, no. 2, pp. 63-68, Mar./Apr. 2009.

**[167]** F. Bouhafs, M. Mackay, and M. Merabti, "Links to the future: Communication requirements and challenges in the smart grid," IEEE Power Energy Mag., vol. 10, no. 1, pp. 24-32, Jan./Feb. 2012.

**[168]** L. Maurer, A. Stevens, and W. Reder, "Tales from the frontline: Keys to successful self-healing distribution projects," IEEE Power Energy Mag., vol. 10, no. 2, pp. 100-106, Mar./Apr. 2012.

**[169]** F. Li et al., "Distribution pricing: are we ready for the smart grid?" IEEE Power Energy Mag., vol. 13, no. 4, pp. 76-86, Jul./Aug. 2015.

**[170]** Kouro, J. I. Leon, D. Vinnikov, and L. G. Franquelo, "Grid-connected photovoltaic systems: An overview of recent research and emerging PV converter technology," IEEE Ind. Electron. Mag., vol. 9, no. 1, pp. 47-61, Mar. 2015.

**[171]** F. Katiraei and J. R. Aguero, "Solar PV integration challenges," IEEE Power Energy Mag., vol. 9, no. 3, pp. 62-71, May/June 2011.

**[172]** M. Smith and D. Ton, "Key connections: The U.S. Department of Energy's Microgrid initiative," IEEE Power Energy Mag., vol. 11, no. 4, pp. 22-27, Jul./Aug. 2013.



**[173]** Z. Bie, Y. Lin, G. Li, and F. Li, “Battling the extreme: A study on the power system resilience,” *Proc. IEEE*, vol. 105, no. 7, pp. 1253–1266, Jul. 2017.

**[174]** F. Katiraei and J. R. Aguero, “Solar PV Integration challenges,” *IEEE Power Energy Mag.*, vol. 9, no. 3, pp. 62–71, May/ Jun

---

## Team - India

Indian Institute of Technology Kanpur				
S. No.	Member Status	Name	Department	Email ID
1	Current Team Members	Dr. Suresh C Srivastava	Electrical Engg.	scs@iitk.ac.in
2		Dr. Santanu Mishra	Electrical Engg.	santanum@iitk.ac.in
3		Dr. Sri Niwas Singh	Electrical Engg.	snsingh@iitk.ac.in
4		Dr. Saikat Chakrabarti	Electrical Engg.	saikate@iitk.ac.in
5		Dr. Ankush Sharma	Electrical Engg.	ansharma@iitk.ac.in
6		Dr. Ketan Rajawat	Electrical Engg.	ketan@iitk.ac.in
7		Dr. Soumya Ranjan Sahoo	Electrical Engg.	srsahoo@iitk.ac.in
8		Dr. Abhejeet Mohapatra	Electrical Engg.	abheem@iitk.ac.in
9		Dr. Gururaj Mirla Vishwanath	Electrical Engg.	gururajmv@iitk.ac.in
10		Dr. Prabodh Bajpai	Sustainable Engg.	pbajpai@iitk.ac.in
11		Dr. Sandeep Shukla	Computer Science	sandeeps@cse.iitk.ac.in
12		Dr. Amey Karkare	Computer Science	karkare@cse.iitk.ac.in
13		Dr. Anoop Singh	Ind. Mgmt. Engg.	anoops@iitk.ac.in
14		Dr. Deep Mukherjee	Economics	deepm@iitk.ac.in
15		Mr. Navpreet Singh	Computer Centre	navi@iitk.ac.in
16		Mr. Vinay Kumar Tiwari	Institute Works Department	vktiwari@iitk.ac.in
17		Mr. Shiv Kumar Singh	Electrical Engg.	shivks@iitk.ac.in
18	Earlier Team Members	Dr. Sandeep Anand (SA)	Electrical Engg.	asandeep@iitk.ac.in
19		Dr. Malay K. Das (MKD)	Mechanical Engg.	mkdas@iitk.ac.in
20		Dr. Anju Meghwani (AMg)	Electrical Engg.	anjum@iitk.ac.in

IIT Delhi				
S. No.	Member Status	Name	Department	Email ID
1	Current Team Members	Dr. Abhijit R. Abhyankar	Electrical Engg.	abhyankar@ee.iitd.ac.in
2		Dr. B. K. Panigrahi	Electrical Engg.	bkpanigrahi@ee.iitd.ac.in
3		Dr. Manav Bhatnagar	Electrical Engg.	manav@ee.iitd.ac.in
4		Dr. Bhim Singh	Electrical Engg.	bsingh@ee.iitd.ac.in
5		Dr. Ranjan Bose	Electrical Engg.	rbose@ee.iitd.ac.in
6	Earlier Team Members	Dr. R. K. Maheshwari (RKM)	Electrical Engg.	rkmahesh@ee.iitd.ac.in

IIT Madras				
S. No.	Member Status	Name	Department	Email ID
1	Current Team Members	Dr. Mahesh Kumar	Electrical Engg.	<a href="mailto:mahesh@ee.iitm.ac.in">mahesh@ee.iitm.ac.in</a>
2		Dr. Srirama Srinivas	Electrical Engg.	<a href="mailto:rsrin12@ee.iitm.ac.in">rsrin12@ee.iitm.ac.in</a>

IIT Roorkee				
S. No.	Member Status	Name	Department	Email ID
1	Current Team Members	Dr. N.P. Padhy	Electrical Engg.	nppadhy@ee.iitr.ac.in
2		Dr. Pramod Agarwal	Electrical Engg.	pramod.agarwal@ee.iitr.ac.in
3		Dr. Dheeraj K Khatod	Electrical Engg.	dheeraj.khatod@ee.iitr.ac.in

IIT Bhubaneswar				
S. No.	Member Status	Name	Department	Email ID
1	Current Team Members	Dr. S.R. Samantaray	School of Electrical Sciences	srs@iitbbs.ac.in
2		Dr. Olive Ray	Electrical Engg.	olive@iitbbs.ac.in

TERI				
S. No.	Member Status	Name	Department	Email ID
1	Current Team Members	Mr. A K Saxena	Policy & Regulatory Expert	ak.Saxena@teri.res.in
2		Mr. K Ramanathan	Power System Expert	karnathan@teri.res.in
3		Mr. Amit Kumar	Social Expert	akumar@teri.res.in
4		Mr. Kapil Muddineni	R&D	kapil.muddineni@teri.res.in
5		Ms. Falti Teotia	R&D	falti.teotia@teri.res.in
6		Mr. Mukesh Kumar		mukesh.kumar@teri.res.in
7		Ms. Ashwini Mudgal	Associate Fellow	ashwini.mudgal@teri.res.in
8		Mr. Praveer Kumar Jha	R&D, Policy Recommendations	praveer.jha@teri.res.in
9		Mr. Tattaiyya Bhattacharjee	Policy Recommendations	
10	Earlier Team Members	Mr. Shirish S Garud		shirishg@teri.res.in
11		Mr. S Narayan Kumar		s.kumar@teri.res.in
12		Mr. Shashank Vyas		Shashank.Vyas@teri.res.in
13		Ram Krishan		ram.krishan@teri.res.in
14		Mr. Debajit Palit		debajitp@teri.res.in
15		Jyoti Sharma		jyoti.sharma@teri.res.in
16		Mr. Abhinav Jain		Abhinav.Jain@teri.res.in
17		Mr. Neshwin Rodrigues		N.Rodrigues@teri.res.in
18		Mr. Alekhya Datta		alekhya.datta@teri.res.in
19		Mr. Ashvini Kumar		ashvini.kumar@teri.res.in

NPTC				
S. No.	Member Status	Name	Department	Email ID
1	Current Team Members	Mr. Subrata Sarkar	Electrical	subratasarkar@ntpc.co.in
2		Mr. Partha Mukherjee	Electrical	pmukherjee01@ntpc.co.in
3		Mr. Ravi Kumar	Electrical	ravikumar@ntpc.co.in
4	Earlier Team Members	Mr. Shish Pal Singh	Electrical	spsundir@ntpc.co.in
5		Mr. Rakesh Swami	Electrical	rakeshswami@ntpc.co.in
6		Mr. Tarun Sharma	Electrical	tarunsharma@ntpc.co.in
7		Mr. Pushpendra Kr Singh	Electrical	pushpendra@ntpc.co.in

Power Grid Corporation of India Limited (PGCIL)				
S. No.	Member Status	Name	Department	Email ID
1	Current Team Members	Mr. Rajesh Kumar	Smart Grid	rajeshkumar@powergrid.in
2		Mr. Manish Kumar Tiwari	Smart Grid	manish.tiwari@powergrid.in
3		Mr. Kashish Bhamabhani	Smart Grid	kashish@powergrid.in
4		Mr. Rajesh Kumar Panda	Smart Grid	rajeshpanda@powergrid.in
5		Mr. Ankur Chakraborty	Smart Grid	a.chakraborty@powergrid.in
6		Mr. Dharan Pratap Singh	Smart Grid	dharan@powergrid.in
7		Mr. Nikhil Kumar	Smart Grid	nikhil.kumar@powergrid.in

DAKSHINANCHAL VIDYUT VITRAN NIGAM LTD (DVVNL), UPPCL				
S. No.	Member Status	Name	Department	Email ID
1	Current Team Members	Chief Engineer Distribution, DVVNL		gmkanpurdvvnl@gmail.com
2		Executive Engineer, EED		eeddchaubepur@gmail.com

BSES Rajdhani Power Limited				
S. No.	Member Status	Name	Department	Email ID
1	Current Team Members	Mr. Naveen Nagpal	DGM - Renewables	naveen.nagpal@relianceada.com
2		Mr. Pankaj Kargeti	Renewables	Pankaj.kargeti@reliance.com
3		Ms. Sugandhita Wadhwa	Graduate Engineer - Renewables	
4	Earlier Team Members	Mr. Abhishek Ranjan	Manager - Renewables	abhishek.r.ranjan@relianceada.com
5		Mr. Bhuvnesh Sharma	Renewables	bhuvnesh.g.sharma@relianceada.com
6		Mr. Chetan Pathak	Renewables	chetan.pathak@relianceada.com

Synergy System & Solutions, Faridabad				
S. No.	Member Status	Name	Department	Email ID
1	Current Team Members	Mr. Vidhu Aggarwal	CEO	vidhu_aggarwal@s3india.com
2		Mr. Krishnan Venkatraman	DGM R&D	v_krishnan@s3india.com
3		Kamakshi Swain	Senior Power System Engineer	kamakshi_swain@s3india.com

Customized Energy Solution (CES), Pune				
S. No.	Member Status	Name	Department	Email ID
1	Current Team Members	Mr. Rahul Walawalkar	ESS	rwalawalkar@ces-ltd.com
2		Mr. Harsh Thacker	Rural Microgrids, Power Distribution	hthacker@ces-ltd.com
3		Mr. Uday Mhaskar		umhaskar@ces-ltd.com
4		Mr. Vinayak Walimbe		vwalimbe@ces-ltd.com
5		Mr. Rajarshi Sen		rsen@ces-ltd.com
6		Mr. Javed Shaikh		jshaikh@ces-ltd.com

GE Global R & D, Bengaluru				
S. No.	Member Status	Name	Department	Email ID
1	Current Team Members	Mr. Arvind K. Tiwari		arvind.tiwari1@ge.com
2		Mr. Yashomani Kolhatkar		yashomani.kolhatkar@ge.com

Shramik Bharti Foundation				
S. No.	Member Status	Name	Department	Email ID
1	Current Team Members	Mr. Rakesh Pandey	Electric Power	rakesh@shramikbharti.org.in
2		Mr. Alok Srivastava		alok.srivastava@shramikbharti.org.in

Panasonic India Pvt. Ltd., Gurgaon				
S. No.	Member Status	Name	Department	Email ID
1	Current Team Members	Mr. Atul Arya	Head Energy System Division	atul.arya@in.panasonic.com
2	Earlier Team Members	Mr. Rishi Diwan		rishi.diwan@in.panasonic.com
3		Mr. Mohit Shukla		mohit.shukla@in.panasonic.com
4		Mr. Amit Mohan Saklani		amit.saklani@in.panasonic.com
5		Mr. Suraj Chaudhry		suraj.chaudhry@in.panasonic.com
6		Mr. Ranajay Mallik		ranajay.mallik@in.panasonic.com





## Team - US

Name	Partner	Position (researcher, staff, finance, etc.)	Email
Ben Shannon	Avista	Engineering	ben.shannon@avistacorp.com
Blake Parker	Avista	Accounting	blake.parker@avistacorp.com
Erik Lee	Avista	Engineering	erik.lee@avistacorp.com
John Gibson	Avista	Engineering	john.gibson@avistacorp.com
Jon Thompson	Avista	Digital Technology	jon.thompson@avistacorp.com
Kit Parker	Avista	Project Management	kit.parker@avistacorp.com
Mike Diedesch	Avista	Engineering	michael.diedesch@avistacorp.com
Tiffany Adams	Avista	Accounting	tiffany.adams@avistacorp.com
Tim Wacker	Avista	Relay Shop	tim.wacker@avistacorp.com
Curt Kirkeby	Avista	Co-PI	curt.kirkeby@avistacorp.com
Amy Lewis	Burns&Mc	Finance	amlewis@burnsmcd.com
Brian Cicariello	Burns&Mc	Technical Support	bcicariello@burnsmcd.com
Chrissy Carr	Burns&Mc	Technical Support	ccarr@burnsmcd.com
Daniel Bayouth	Burns&Mc	Technical Support	dbayouth@burnsmcd.com
Francisco Neto	Burns&Mc	Co-PI	jneto@burnsmcd.com
Gary Huffman	Burns&Mc	PI	gbhuffman@burnsmcd.com
John Amos	Burns&Mc	Technical Support	jbamos@burnsmcd.com
John Biasi	Burns&Mc	Technical Support	jrbiase@burnsmcd.com
Lynette Kithinji	Burns&Mc	Technical Support	lgkithinji@burnsmcd.com
Meghan Calabro	Burns&Mc	Technical Support	mcalabro@burnsmcd.com
Mike Kloiber	Burns&Mc	Technical Support	mkloiber@burnsmcd.com
Nick Mozer	Burns&Mc	Technical Support	nrmozer@burnsmcd.com
Sami Pathan	Burns&Mc	Technical Support	spathan@burnsmcd.com
Ahmed Saber	ETAP	PI	ahmed.saber@etap.com
Aparna Sinha	ETAP	Project Engineer	Aparna.Sinha@etap.com
Sifang Zhao	ETAP	Project Engineer	Sifang.Zhao@etap.com
Vivek Jayaraman	ETAP	Project Engineer	Vivek.Jayaraman@etap.com
Abilash Thakallapelli	GE	Sr. Software Engineer	abilash.thakallapelli@ge.com
Alicia Toney	GE	Technical	Alicia.Toney@ge.com
Asif Lalani	GE	Ex-Project Manager	asif.lalani@ge.com
Dinu Robert	GE	Technical	robert-cristian.dinu@ge.com
Ethan Boardman	GE	Technical	
Jacki Myers	GE	Technical	jacki.myers@ge.com
Jayant Kumar	GE	Administrative/Technical Lead	jayant.kumar@ge.com
John McDonald	GE	Expert Advisor	john.d.mcdonald@ge.com
Jun Zha	GE	Co-Technical Lead	jun.zha@ge.com
Kevin Dine	GE	Technical	
Marion Dumitrascu	GE	Technical	Marion.Dumitrascu@ge.com
Max Salcedo	GE	Project Manager	maximiliano.salcedo@ge.com
Ryan Edwards	GE	PMO Director	ryan.edwards@ge.com
Sajal Agrawal	GE	Project Manager	SAJAL.AGRAWAL@ge.com
Tami Lau	GE	Project finance	tami.lau@ge.com
Vinoth Mohan	GE	Sr. Manager - Software Engineer	vinoth.mohan@ge.com
Vivek Joshi	GE	Power System Engineer	vivek.joshi@ge.com
Dax Matthews	Hawaii	Faculty	daxm@hawaii.edu
Kevin Davies	Hawaii	PI/Admin	kdavies@hawaii.edu
Leon Roose	Hawaii	Co-PI	lroose@hawaii.edu
Thai Tran	Hawaii	technical	thaitran@hawaii.edu
Jhi-Young Joo	LBL	PI	joo3@lbl.gov
Monique Fix	LBL	Finance	mfix@lbl.gov
Nicholas DeForest	LBL	Researcher	ndeforest@lbl.gov
Vincent Battaglia	LBL	Researcher	vsbattaglia@lbl.gov
Aaleshea Tran	LNTECC	Adjunct Project Manager	aaleshea.tran@Intecc.com
Asif Lalani	LNTECC	Program Manager	asif.lalani@Intecc.com
Devendra Vishwakarma	LNTECC	Chief Technology Officer	
Bragadees Raja	LNTECC	Engineer	bragadees.r@Intecc.com
Gopinath selvaraj	LNTECC	Engineer	gopinathselvaraj@Intecc.com
Juan Hernandez	LNTECC	Project Manager	juan.hernandez@Intecc.com
Mruga T Shah	LNTECC	Software Engineer	mruga.shah@Intecc.com
Pritpal Khanuja	LNTECC	Head - Product Manager	K-PRITPAL@Intecc.com
Priya Somashekaraiah Prasadswamy	LNTECC	Product Analyst	priya.prasadaswamy@Intecc.com



Rajeev Kumar Jaiswal	LNTECC	Sr Lead Technical Program Manager	jaiswalrk@lntecc.com
Vairamuthu Ramalingam	LNTECC	Engineer	Vairamuthu.a@lntecc.com
Jayant Kumar	LNTECC	PI (previously with GE)	JAYANTKUMAR@lntecc.com
Anuradha Annaswamy	MIT	PI, Researcher	aanna@mit.edu
Theresa Peterson	MIT	Finance	theresap@mit.edu
Rabab Haider	MIT	PhD Student	rhaider@mit.edu
Adaora Ifebigh	NRECA	Project Manager	adaora.ifebigh@nreca.coop
Craig Miller	NRECA	PI	No longer with NRECA
David Pinney	NRECA	Researcher/PI	david.pinney@nreca.coop
Manish Mohanpurkar	NREL	Senior Researcher	manish.mohanpurkar@nrel.gov
Mayank Panwar	NREL	Senior Researcher	mayank.panwar@nrel.gov
Rob Hovsopian	NREL	Principal Investigator for NREL	rob.hovsopian@nrel.gov
Sayansom Chanda	NREL	Technical Lead	Sayansom.Chanda@nrel.gov
Stephanie Hernandez	NREL	Finance	Stephanie.Hernandez@nrel.gov
Yashodhan Agalgaonkar	NREL	Senior Researcher	Yashodhan.Agalgaonkar@nrel.gov
Alasdair Crawford	PNNL	Researcher	alasdair.crawford@pnnl.gov
Jan Alam	PNNL	Researcher	jan.eec.alam@gmail.com
Mallorie McDowell	PNNL	Finance	mallorie.mcdowell@pnnl.gov
Mary Foraker	PNNL	Finance	mary.hughes@pnnl.gov
Patrick Balducci	PNNL	PI	No longer with PNNL
Vincent Sprenkle	PNNL	Project Manager	Vincent.Sprenkle@pnnl.gov
Vish Viswanathan	PNNL	PI/Researcher	Vilayanur.Viswanathan@pnnl.gov
Chris Zacharia	SNOPUD	Technical	No longer with SnoPUD
Alexander Chorey	SNOPUD	Principal Engineer	amchorey@snopud.com
Andra Flaherty	SNOPUD	Mgr, Trans & Strds Engineering	alflaherty@snopud.com
Jason Zyskowski	SNOPUD	AGM Gen, Pwr, Rates & Trans Mgm	jazyskowski@snopud.com
Jeanne Harshbarger	SNOPUD	Mgr System Plan & Protect	jwharshbarger@snopud.com
John Hieb	SNOPUD	Principal Engineer	JDHieb@snopud.com
Kevin Lavering	SNOPUD	Program Manager	kglovering@snopud.com
Kris Scudder	SNOPUD	Principal Utility Analyst	krscudder@snopud.com
Scott Gibson	SNOPUD	Mgr, Enrgy Stor & Emerg Tech	hsgibson@snopud.com
Travis Olson	SNOPUD	Senior Project Manager	twolson@snopud.com
Tyler Reinitz	SNOPUD	Principal Engineer	trreinitz@snopud.com
Zack Scott	SNOPUD	Principal Engineer	zmScott@snopud.com
Chanan Singh	TAMU	Co-PI	singh@ece.tamu.edu
Deshaun Tolbert	TAMU	Program Specialist	skyline1996@tamu.edu
Megan Lefner	TAMU	Project Administrator	mlefnr@tamu.edu
Miroslav M. Begovic	TAMU	Co-PI	begovic@tamu.edu
Mladen Kezunovic	TAMU	PI	kezunov@ece.tamu.edu
Rachel Rose	TAMU	Communications/PR	rachel.rose@tamu.edu
Subrahmanyam Venkata	Venkata Consulting	Lead	ssvenkata@comcast.net
Adam Hahn	WSU	Co-PI	No longer at WSU
Anjan Bose	WSU	Co-PI	bose@wsu.edu
Assefaw Gebremedhin	WSU	Co-PI	assefaw.gebremedhin@wsu.edu
Christine Horne	WSU	Co-PI	chorne@wsu.edu
Noel Schulz	WSU	Lead PI	noel.schulz@wsu.edu
Yinghui Wu	WSU	Co-PI	No longer at WSU
Sanjeev Pannala	WSU	US Technical Co-Leader	sanjeev.pannala@wsu.edu
Jeannine Burke	WSU	Budget Coordinator	burkejl@wsu.edu
Dianne Daley Laursen	WSU	UI-ASSIST Project Coordinator	No longer at WSU
Jody Opheim	WSU	UI-ASSIST Project Coordinator	No longer at WSU
Brenna Peever	WSU	UI-ASSIST Project Coordinator	No longer at WSU
Tiffani Stubblefield	WSU	UI-ASSIST Project Coordinator	t.stubblefield@wsu.edu
Sajan Kaduvettykunnal Sadanandan	WSU	Post-doc	No longer at WSU
Subir Majumder	WSU	Post-doc	No longer at WSU
Pratim Kudu	WSU	Post-doc	No longer at WSU
Anurag Srivastava	WSU/WVU	US Technical Co-Lead WSU/PI WVU	anurag.srivastava@mail.wvu.edu
Subir Majumder	WVU	Researcher (formerly at WSU)	subir.majumder@mail.wvu.edu



## U.S. INDIA COLLABORATIVE FOR **SMART** DISTRIBUTION SYSTEM WITH **STORAGE**



[www.uiassist.org](http://www.uiassist.org)



[uiassist@iitk.ac.in](mailto:uiassist@iitk.ac.in)

